

Shotgun Microphone
ECM-B10

Use this Help Guide when you have issues or questions on how to use your shotgun microphone.



Supported camera models

This unit is a microphone compatible with the Multi Interface Shoe.
For camera models compatible with this unit, view [here](#). (Another window will open.)
In combination with any camera model that is not listed on the website, the unit does not work.

[Identifying the parts](#)

Preparations

[Unpacking](#)

[Attaching/removing to/from the camera](#)

[About the pickup pattern and the frequency response](#)

About this unit

[Notes on use](#)

[Specifications](#)

[Trademarks](#)

[When the message “This accessory is not supported by the device and cannot be used.” is displayed on the camera:](#)

Shotgun Microphone
ECM-B10

Identifying the parts

Top, Side, and Bottom

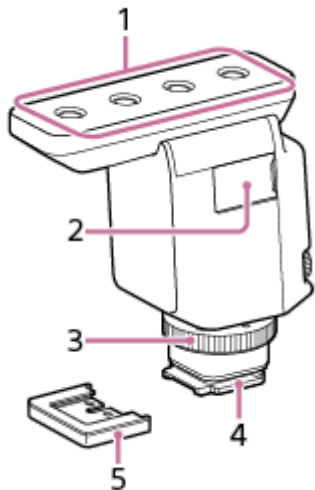

1. Microphone
2. Micro USB port (for maintenance and service use)
3. Lock dial
4. Multi Interface foot

Note

- Do not touch the connector of the Multi Interface foot with bare hands.

5. Connector protect cap

Back

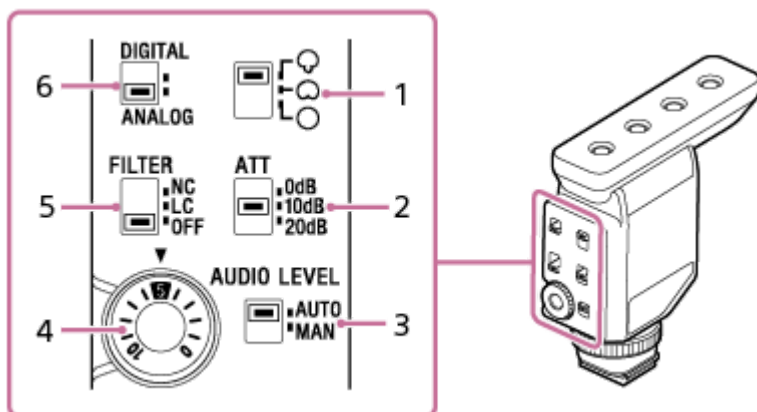

1. Directivity selection switch

☉: Super-directional

Provides a sharp directivity to pick up the sounds coming from the front. You can focus on recording the sounds coming from the camera front while minimizing the surrounding sounds.

☉: Unidirectional

You can record the sounds coming across from the front while minimizing those coming from the back.

○: Omnidirectional

Provides the same directivity to pick up the sounds coming from every direction. Select this directivity when you want to record environmental sounds in particular or include the voice of a photographer in the recording.

2. ATT switch

Select the option suitable for the audio recording volume. To record loud sounds while minimizing distortion, select "20dB." To record quiet sounds while amplifying the sounds, select "0dB." It is recommended that you select an option while monitoring the volume level meter on the camera or the audio recording volume with headphones.

3. AUTO/MAN switch

AUTO: The recording volume level is automatically adjusted.

MAN: Adjust the recording volume with the AUDIO LEVEL dial.

4. AUDIO LEVEL dial

The recording volume level can be adjusted manually for fine tuning when the AUTO/MAN switch is set to "MAN." It is recommended that you adjust the level while monitoring the volume level meter on the camera or the audio recording volume with headphones.

5. FILTER switch

NC: Select this option to use the noise cut filter function. Unpleasant noises are effectively eliminated by digital signal processing. If the sound quality does not seem appropriate, select "OFF."

LC: Select this option to use the low cut filter function. Unwanted noises, such as wind noise, air-conditioning noise, and vibration noise, are minimized.

OFF: Select this option to disable either of the filter functions.

Note

- Hand-held use of the attached camera in a quiet place may cause a soft vibrating sound to be recorded. If the recorded vibrating sound is disturbing, set the FILTER switch to "LC" and try all over again.

6. DIGITAL/ANALOG switch

Select the digital or analog input type.

- If your camera is compatible with the digital audio interface of the Multi Interface Shoe, set the switch to "DIGITAL."
This allows the unit and the attached camera to communicate with each other with digital signals and provide audio recording with minimum noise insertion.
- If your camera is not compatible with the digital audio interface of the Multi Interface Shoe, set the switch to "ANALOG."
When the message "This accessory is not supported by the device and cannot be used." is displayed on the camera, set the switch to "ANALOG."
If this does not help, see [here](#).

About the wind screen

By fitting the wind screen over the microphone of the unit, you can minimize the noise caused by the wind or breath hitting the microphone to be included in the recording.

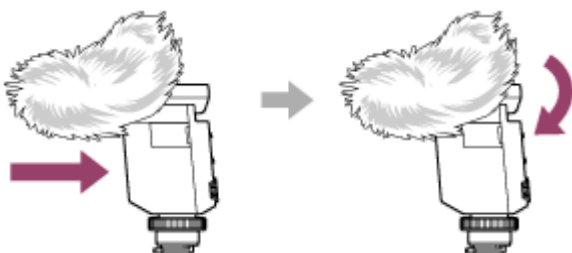

Note

- If the wind screen is exposed to rain and wet, remove it from the unit and let it dry in the shade.

Related Topic

- [Attaching/removing to/from the camera](#)
- [About the pickup pattern and the frequency response](#)

5-036-505-11(1) Copyright 2021 Sony Corporation

Shotgun Microphone
ECM-B10

Unpacking

If you find anything missing, please contact your dealer.
The number in the parentheses indicates the quantity.

- Shotgun Microphone (1)
- Wind screen (1)
- Connector protect cap (attached) (1)
- Pouch (1)
- Set of printed documentation

Attaching/removing to/from the camera

Attach the shotgun microphone to a camera.

Note

- Before attaching/removing this unit to/from a camera, turn off the power to the camera.

1 Remove the connector protect cap from this unit.

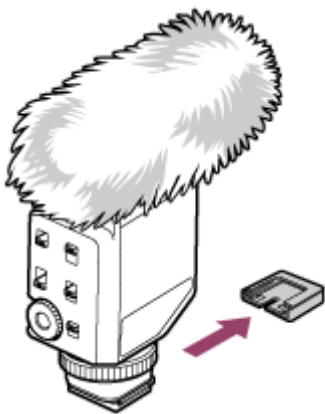

2 Attach this unit to the camera (①) and rotate the lock dial in the "LOCK" direction (②) to firmly secure the unit.

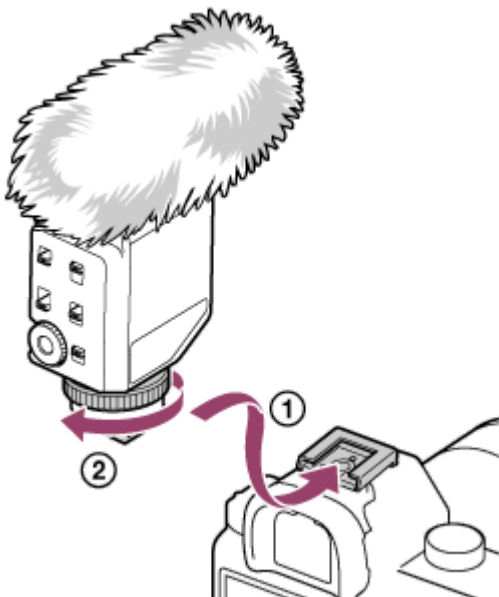

Attaching this unit to a camera automatically switches the audio input from the built-in microphone to the external microphone (this unit). When it is difficult to insert the Multi Interface foot into the shoe, rotate the lock dial counterclockwise until it stops, and then try again.

3 Operate the camera to start recording.

For details, refer to the Help Guide provided for the camera.

To remove the shotgun microphone

Turn off the power to the camera, rotate the lock dial counterclockwise until it stops, and then slide out the Multi Interface foot from the shoe.

5-036-505-11(1) Copyright 2021 Sony Corporation

Shotgun Microphone
ECM-B10

About the pickup pattern and the frequency response

Super-directional pickup pattern

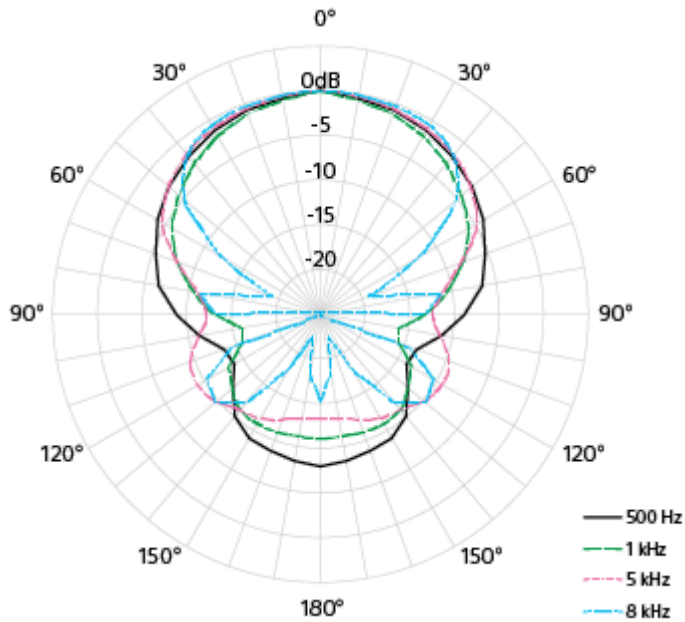

Super-directional frequency response

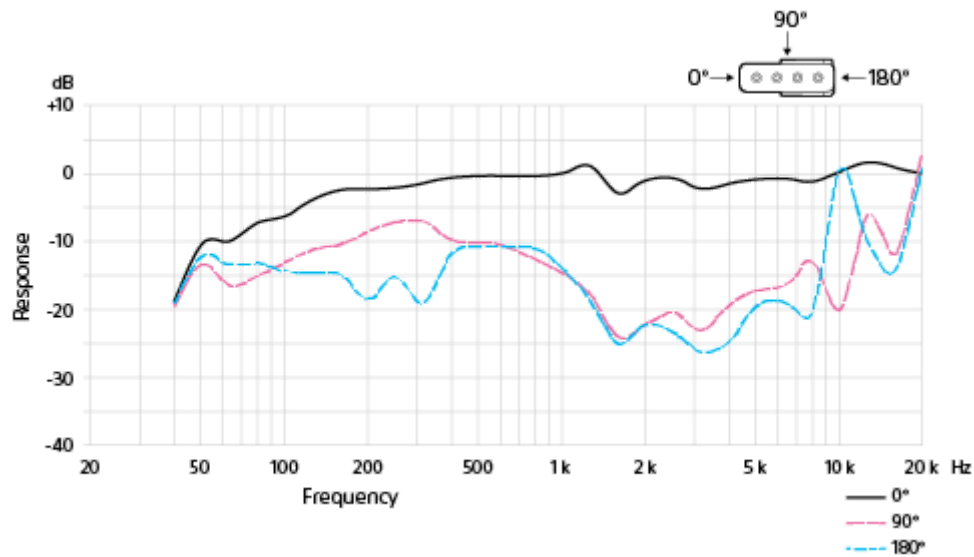

Unidirectional pickup pattern

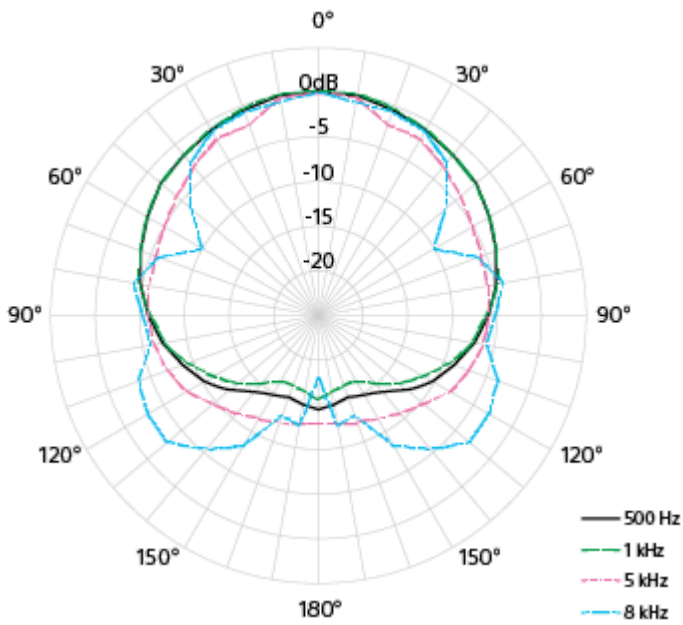

Unidirectional frequency response

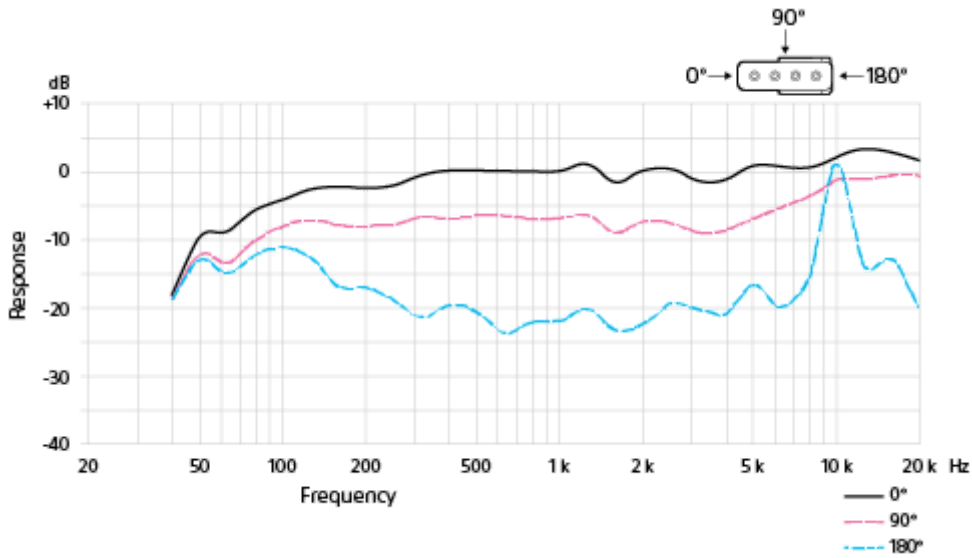

Omnidirectional pickup pattern

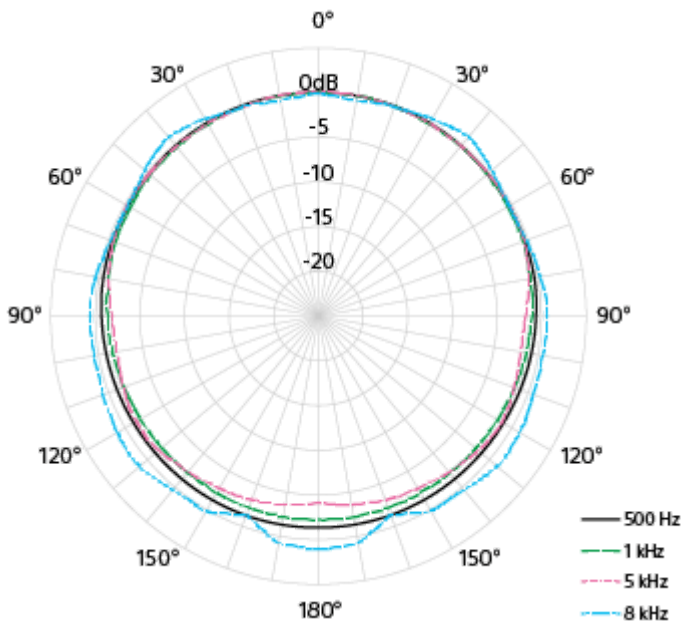

Omnidirectional frequency response

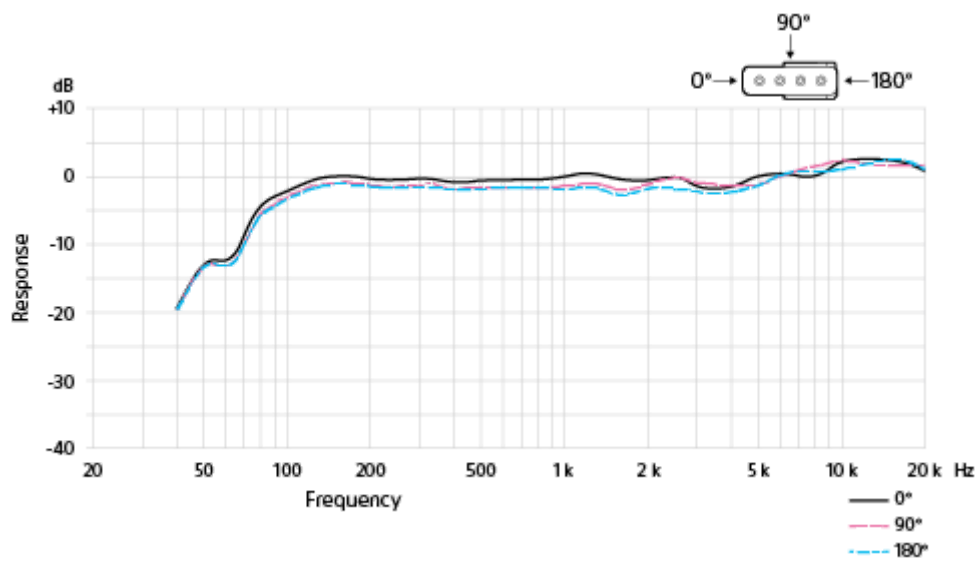

5-036-505-11(1) Copyright 2021 Sony Corporation

Shotgun Microphone
ECM-B10

Notes on use

- To protect the connector of the Multi Interface foot from damage while carrying around this unit, remove the unit from the camera, attach the connector protect cap to the foot and put the unit in the supplied pouch.
- While recording is in progress, operation and handling noises of a camera or a lens may be recorded. Touching this unit while recording is in progress causes a noise to be included in the recording.
- Monitoring or recording voice with the microphone of a camera may cause a slight delay of the voice.
- Before changing the lens, make sure that no wind screen fibers are present on the surface of the lens and the camera body. If present, clean them off with a blower etc. and then change the lens.
- If dust or water droplets are present on the surface of the microphone, a successful recording may not be possible. Be sure to clean the microphone surface before using this unit.

Shotgun Microphone
ECM-B10

Specifications

Type	Back electret condenser type
Frequency response	40 Hz to 20 000 Hz
Pickup pattern	Super-directional / unidirectional / omnidirectional (selectable)
Front sensitivity^{*1}	-20 dBFS (0.1 Pa, 1 kHz)
Intrinsic noise^{*1 *2}	15 dB SPL or less (0 dB = 2×10^{-5} Pa)
Wind noise^{*1 *3}	50 dB SPL or less (without the wind screen attached) 30 dB SPL or less (with the wind screen attached)
Maximum input sound pressure level	120 dB SPL ^{*1 *4}
Dynamic range^{*2}	105 dB or more
Operation temperatures	0 °C to 40 °C (32 °F to 104 °F)
Storage temperatures	-20 °C to +55 °C (-4 °F to +131 °F)
Dimensions (Approx.)	27.4 mm × 81.7 mm × 79.3 mm (Width/Height/Depth) (1 1/8 in. × 3 1/4 in. × 3 1/8 in.) (excluding the wind screen and projecting parts)
Mass (Approx.)	72 g (2.6 oz)

*1 Acquired by setting the AUTO/MAN switch and the ATT switch to "AUTO" and "10dB," respectively.

*2 Acquired by setting the DIGITAL/ANALOG switch to "DIGITAL."

*3 Equivalent sound pressure level value converted from the average value of the noise that is output from the microphone when a wind velocity of 2 m/sec. is applied. (0 dB = 2×10^{-5} Pa)

*4 Equivalent sound pressure level value converted from the input level value that is acquired when 1% waveform distortion is produced by 1 kHz output signals from the microphone. (0 dB = 2×10^{-5} Pa)

Design and specifications are subject to change without notice.

Shotgun Microphone
ECM-B10

Trademarks

- “Multi Interface Shoe” is a trademark of Sony Group Corporation.

Shotgun Microphone
ECM-B10

When the message “This accessory is not supported by the device and cannot be used.” is displayed on the camera:

Do the following in the listed order.

1 Make sure that your camera is compatible with this unit.

For camera models compatible with this unit, visit the website at:
<https://www.sony.net/dics/b10/>

Note

- In combination with any camera model that is not listed on the above website, the unit does not work.

2 To use a camera that is not compatible with the digital audio interface in combination with this unit, set the DIGITAL/ANALOG switch on the unit to “ANALOG.”

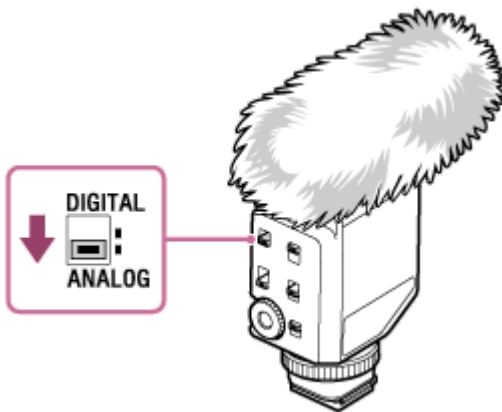

3 Clean the contacts on this unit and the camera. When either or both of the contacts are soiled with dust or the like, the camera may fail to detect that the unit is attached. To clean the contacts, use a cotton swab or a dry, soft cloth (e.g., a cleaning cloth). Do not use water or chemicals for cleaning.