



# Cisco UCS B200 M5 Blade Server

CISCO SYSTEMS  
170 WEST TASMAN DR.  
SAN JOSE, CA, 95134  
[WWW.CISCO.COM](http://WWW.CISCO.COM)

PUBLICATION HISTORY  
REV D.04 JULY 02, 2020

---

<b>OVERVIEW</b>	<b>3</b>
<b>DETAILED VIEWS</b>	<b>4</b>
<b>BASE SERVER STANDARD CAPABILITIES and FEATURES</b>	<b>5</b>
<b>CONFIGURING the SERVER</b>	<b>7</b>
STEP 1 CHOOSE BASE SERVER SKU	8
STEP 2 CHOOSE CPU(S)	9
STEP 3 CHOOSE MEMORY	16
STEP 4 CHOOSE MLOM ADAPTER	22
STEP 5 CHOOSE SOFTWARE	24
STEP 6 CHOOSE OPTIONAL REAR MEZZANINE ADAPTERS (VIC, NVMe or GPU)	25
STEP 7 CHOOSE OPTIONAL FRONT MEZZANINE ADAPTER	27
STEP 8 CHOOSE OPTIONAL DRIVES	29
STEP 9 CHOOSE OPTIONAL SECURE DIGITAL CARDS or M.2 DRIVES	35
STEP 10 CHOOSE OPTIONAL TRUSTED PLATFORM MODULE	37
STEP 11 CHOOSE OPTIONAL INTERNAL USB 3.0 DRIVE	38
STEP 12 CHOOSE OPERATING SYSTEM AND VALUE-ADDED SOFTWARE	39
STEP 13 CHOOSE OPTIONAL OPERATING SYSTEM MEDIA KIT	43
STEP 14 CHOOSE SERVICE and SUPPORT LEVEL	44
<b>SUPPLEMENTAL MATERIAL</b>	<b>50</b>
<b>SPARE PARTS</b>	<b>56</b>
<b>UPGRADING or REPLACING CPUs</b>	<b>64</b>
<b>UPGRADING or REPLACING MEMORY</b>	<b>65</b>
<b>DISCONTINUED EOL PRODUCTS</b>	<b>67</b>
<b>TECHNICAL SPECIFICATIONS</b>	<b>70</b>

## OVERVIEW

Delivering performance, versatility and density without compromise, the Cisco UCS B200 M5 Blade Server addresses the broadest set of workloads, from IT and web infrastructure through distributed database.

The enterprise-class Cisco UCS B200 M5 blade server extends the capabilities of Cisco's Unified Computing System portfolio in a half-width blade form factor. The Cisco UCS B200 M5 harnesses the power of the latest Intel® Xeon® processor scalable family CPUs with up to 3072 GB of RAM (using 128 GB DIMMs), two solid-state drives (SSDs) or hard disk drives (HDDs), and up to 80 Gbps throughput connectivity.

The May 2019 update includes support for the following:

- 2<sup>nd</sup> Generation Intel® Xeon® Scalable Processors.
- 2933-MHz DDR4 memory DIMMs.
- 128 GB, 256 GB, 512 GB Intel® Persistent Memory Modules (PMEM).
- Up to 9 TB of memory is available if the memory slots are populated as follows:
  - 12 x 256 GB DDR4 DIMMs
  - 12 x 512 GB PMEMs

Figure 1 Cisco UCS B200 M5 Blade Server



# DETAILED VIEWS

## Blade Server Front View

Figure 2 is a detailed front view of the Cisco UCS B200 M5 Blade Server.

Figure 2 Blade Server Front View

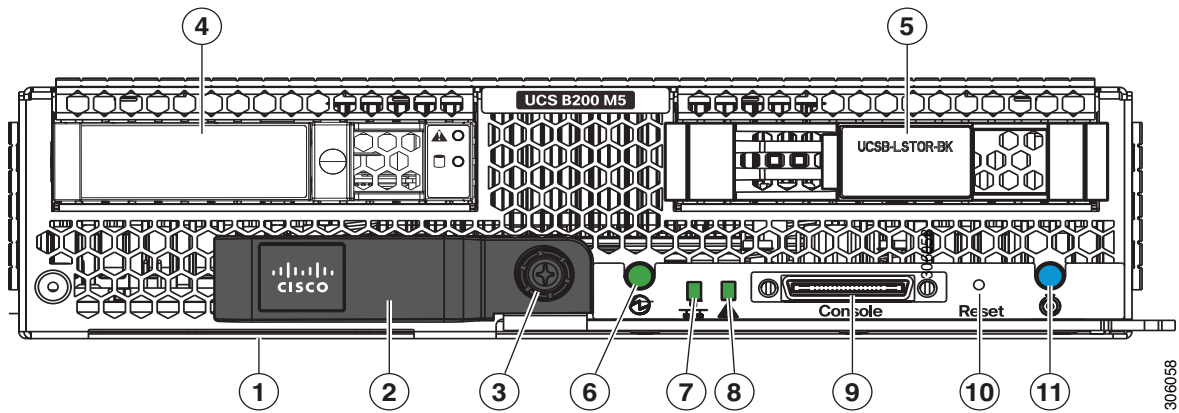

1	Asset pull tag Each server has a plastic tag that pulls out of the front panel. The tag contains the server serial number as well as the product ID (PID) and version ID (VID). The tag also allows you to add your own asset tracking label without interfering with the intended air flow.	7	Network link status
2	Blade ejector handle	8	Blade health LED
3	Ejector captive screw	9	Console connector <sup>1</sup>
4	Drive bay 1	10	Reset button access
5	Drive bay 2	11	Locator button and LED
6	Power button and LED		

**Notes:**

1. A KVM I/O cable plugs into the console connector, and can be ordered as a spare. The KVM I/O cable is included with every Cisco UCS 5100 Series blade server chassis accessory kit.

## BASE SERVER STANDARD CAPABILITIES and FEATURES

*Table 1* lists the capabilities and features of the base server. Details about how to configure the server for a listed feature or capability (for example, number of processors, disk drives, or amount of memory) are provided in *CONFIGURING the SERVER on page 7*

Table 1 Capabilities and Features

Capability/Feature	Description
Chassis	The UCS B200 M5 Blade Server mounts in a Cisco UCS 5108 Series blade server chassis or UCS Mini blade server chassis.
CPU	One or two Intel® Xeon® scalable family CPUs or one or two 2 <sup>nd</sup> Generation Intel® Xeon® scalable family CPUs. Also note that the B200 M5 Blade Server BIOS inherently enables support for Intel Advanced Encryption Standard New Instructions (AES-NI) and does not have an option to disable this feature.
Chipset	Intel® C620 series chipset (Lewisburg)
Memory	<ul style="list-style-type: none"> <li>■ 24 total DIMM slots</li> <li>■ Support for Advanced ECC</li> <li>■ Support for registered ECC DIMMs (RDIMMs)</li> <li>■ Support for load-reduced DIMMs (LR DIMMs)</li> <li>■ Support for through-silicon via DIMMs (TSV DIMMs)</li> <li>■ Support for Persistent DIMMs (PMEMs)</li> <li>■ Up to 3072 GB DDR4 DIMM memory capacity (24 x 128 GB DIMMs)</li> <li>■ Up to 9 TB memory with a mix of DIMMs and PMEMs               <ul style="list-style-type: none"> <li>• 12 x 256 GB DIMMs</li> <li>• 12 x 512 GB PMEMs</li> </ul> </li> </ul>
Modular LOM	One modular LOM (mLOM) connector at the rear of the blade for a Cisco mLOM VIC adapter, which provides Ethernet or Fibre Channel over Ethernet (FCoE) connectivity
Mezzanine Adapters (Rear)	<p>One rear mezzanine connector for various types of Cisco mezzanine adapters</p> <ul style="list-style-type: none"> <li>■ Cisco Mezzanine VIC Adapter, or</li> <li>■ Cisco Mezzanine Port Expander, or</li> <li>■ Cisco Mezzanine NVMe Storage Adapter, or</li> <li>■ Cisco Mezzanine nVIDIA P6 GPU (can also be placed in front connector)</li> </ul>
Mezzanine Adapters (Front)	<p>One front mezzanine connector for</p> <ul style="list-style-type: none"> <li>■ Cisco FlexStorage controller with drive bays, or</li> <li>■ Cisco Mezzanine nVIDIA P6 GPU (can also be placed in rear connector)</li> </ul> <p>NOTE: No front GPUs are allowed with CPUs that dissipate equal to or more than 165 W.</p>

Table 1 Capabilities and Features (*continued*)

Capability/Feature	Description
Storage controller	<p>For the front mezzanine connector:</p> <ul style="list-style-type: none"> <li>■ Cisco FlexStorage 12G RAID controller with drive bays</li> <li>■ Cisco FlexStorage 12G RAID controller with 2GB Cache with drive bays</li> <li>■ Cisco FlexStorage NVMe Passthrough controller with drive bays (you can also have an NVMe storage adapter in the rear mezzanine connector at the same time)</li> </ul>
Storage devices	<p>Up to two optional, front-accessible, hot-swappable, 2.5-inch small form factor (SFF) drive slots. Choice of:</p> <ul style="list-style-type: none"> <li>■ 10K RPM or 15K RPM hard disk drives (HDD)</li> <li>■ Enterprise performance or enterprise value solid state drives (SSD)</li> <li>■ High or medium endurance NVMe Drives</li> </ul> <p>Internal mini-storage modules that can accommodate either:</p> <ul style="list-style-type: none"> <li>■ Up to two SD modules (32 GB, 64 GB, or 128 GB supporting RAID 1, or</li> <li>■ Up to two M.2 SATA drives (240 GB or 960 GB) supported by LSI SW RAID</li> </ul> <p>Internal UCS 3.0 Port that can accommodate a Cisco 16 GB USB drive</p>
Video	<p>The Cisco Integrated Management Controller (CIMC) provides video using a Matrox G200e video/graphics controller.</p> <ul style="list-style-type: none"> <li>■ Integrated 2D graphics core with hardware acceleration</li> <li>■ DDR4 memory interface supports up to 512 MB of addressable memory (8 MB is allocated by default to video memory)</li> <li>■ Supports display resolutions up to 1920 x 1200 32 bpp@ 60Hz</li> <li>■ Single lane PCI-Express host interface running at Gen 2 speed</li> </ul>
Interfaces	One KVM console connector on the front panel
Power subsystem	Integrated in the Cisco UCS 5108 blade server chassis
Fans	Integrated in the Cisco UCS 5108 blade server chassis.
Integrated management processor	The built-in Cisco Integrated Management Controller (CIMC) GUI or CLI interface enables monitoring of server inventory, health, and system event logs
ACPI	Advanced Configuration and Power Interface (ACPI) 4.0 Standard Supported.

## CONFIGURING the SERVER

Follow these steps to configure the Cisco UCS B200 M5 Blade Server:

- *STEP 1 CHOOSE BASE SERVER SKU, page 8*
- *STEP 2 CHOOSE CPU(S), page 9*
- *STEP 3 CHOOSE MEMORY, page 16*
- *STEP 4 CHOOSE MLOM ADAPTER, page 22*
- *STEP 5 CHOOSE SOFTWARE, page 24*
- *STEP 6 CHOOSE OPTIONAL REAR MEZZANINE ADAPTERS (VIC, NVMe or GPU), page 25*
- *STEP 7 CHOOSE OPTIONAL FRONT MEZZANINE ADAPTER, page 27*
- *STEP 8 CHOOSE OPTIONAL DRIVES, page 29*
- *STEP 9 CHOOSE OPTIONAL SECURE DIGITAL CARDS or M.2 DRIVES, page 35*
- *STEP 10 CHOOSE OPTIONAL TRUSTED PLATFORM MODULE, page 37*
- *STEP 11 CHOOSE OPTIONAL INTERNAL USB 3.0 DRIVE, page 38*
- *STEP 12 CHOOSE OPERATING SYSTEM AND VALUE-ADDED SOFTWARE, page 39*
- *STEP 13 CHOOSE OPTIONAL OPERATING SYSTEM MEDIA KIT, page 43*
- *STEP 14 CHOOSE SERVICE and SUPPORT LEVEL, page 44*

## STEP 1 CHOOSE BASE SERVER SKU

Verify the product ID (PID) of the server as shown in [Table 2](#).

Table 2 PID of the Base UCS B200 M5 Blade Server

Product ID (PID)	Description
UCSB-B200-M5	UCS B200 M5 Blade Server without CPU, memory, drive bays, HDD, VIC adapter, or mezzanine adapters (ordered as a blade chassis option)
UCSB-B200-M5-U	UCS B200 M5 Blade Server without CPU, memory, drive bays, HDD, VIC adapter, or mezzanine adapters (ordered standalone)
UCSB-B200-M5-CH	DISTI: UCS B200 M5 Blade Server without CPU, memory, drive bays, HDD, VIC adapter, or mezzanine adapters

A base Cisco UCS B200 M5 blade server ordered in [Table 2](#) does not include any components or option They must be selected during product ordering.

Please follow the steps on the following pages to order components such as the following, which are required in a functional blade:

- CPUs
- Memory
- Cisco FlexStorage RAID controller with drive bays (or blank, for no local drive support)
- Drives
- Cisco adapters (such as the VIC 1340, VIC 1380, VIC 1440, VIC 1480, or Port Expander)
- Cisco UCS NVMe Flash Storage Adapters or GPUs



## STEP 2 CHOOSE CPU(S)

The standard CPU features are:

- Intel® Xeon® scalable processor family CPUs and 2<sup>nd</sup> Generation Intel® Xeon® scalable processor family CPUs.
- Intel® C620 series chipset
- Up to 28 cores per processor, for a total of up to 56 cores per server
- Please refer to the notes below on ambient inlet temperature requirements and allowed Mezz Card Configuration due to CPU thermal requirements.



### NOTE:

The CPUs designated as Ix2xx are 2<sup>nd</sup> Generation Intel® Xeon® scalable processor family CPUs.

Select CPUs from [Table 3](#).

Table 3 Available CPUs

Product ID (PID) <sup>1</sup>	Clock Freq (GHz)	Power (W)	Cache Size (MB)	Cores	UPI <sup>2</sup> Links (GT/s)	Highest DDR4 DIMM Clock Support (MHz) <sup>3</sup>	Workload
<b>Cisco Recommended Processors <sup>4, 5</sup> (2nd Generation Intel® Xeon® Processors)</b>							
UCS-CPU-I8276	2.2	165	38.50	28	3 x 10.4	2933	Oracle, SAP
UCS-CPU-I8260	2.4	165	35.75	24	3 x 10.4	2933	Microsoft Azure Stack
UCS-CPU-I6262V	1.9	135	33.00	24	3 x 10.4	2400	Virtual Server infrastructure or VSI
UCS-CPU-I6248R	3.0	205	35.75	24	2 x 10.4	2933	
UCS-CPU-I6248	2.5	150	27.50	20	3 x 10.4	2933	VDI, Oracle, SQL, Microsoft Azure Stack
UCS-CPU-I6238R	2.2	165	38.50	28	2 x 10.4	2933	Oracle, SAP (2-Socket TDI only), Microsoft AzureStack
UCS-CPU-I6238	2.1	140	30.25	22	3 x 10.4	2933	SAP
UCS-CPU-I6234	3.3	130	24.75	8	3 x 10.4	2933	Oracle, SAP
UCS-CPU-I6230R	2.1	150	35.75	26	2 x 10.4	2933	Virtual Server Infrastructure, Data Protection, Big Data, Splunk, Microsoft AzureStack
UCS-CPU-I6230	2.1	125	27.50	20	3 x 10.4	2933	Big Data, Virtualization
UCS-CPU-I5220R	2.2	150	35.75	24	2 x 10.4	2666	Virtual Server Infrastructure, Splunk, Microsoft Azure Stack
UCS-CPU-I5220	2.2	125	24.75	18	2 x 10.4	2666	HCI

Table 3 Available CPUs (continued)

Product ID (PID) <sup>1</sup>	Clock Freq (GHz)	Power (W)	Cache Size (MB)	Cores	UPI <sup>2</sup> Links (GT/s)	Highest DDR4 DIMM Clock Support (MHz) <sup>3</sup>	Workload
UCS-CPU-I5218R	2.1	125	27.50	20	2 x 10.4	2666	Virtual Server Infrastructure, Data Protection, Big Data, Splunk, Scale-out Object Storage, Microsoft AzureStack
UCS-CPU-I5218	2.3	125	22.00	16	2 x 10.4	2666	Virtualization, Microsoft Azure Stack, Splunk, Data Protection
UCS-CPU-I4216	2.1	100	22.00	16	2 x 9.6	2400	Data Protection, Scale Out Storage
UCS-CPU-I4214R	2.4	100	16.50	12	2 x 9.6	2400	Data Protection, Splunk, Scale-out Object Storage, Microsoft AzureStack
UCS-CPU-I4214	2.2	85	16.75	12	2 x 9.6	2400	Data Protection, Scale Out Storage
UCS-CPU-I4210R	2.4	100	13.75	10	2 x 9.6	2400	Virtual Server Infrastructure, Data Protection, Big Data, Splunk
UCS-CPU-I4210	2.2	85	13.75	10	2 x 9.6	2400	Virtualization, Big Data, Splunk
<b>8000 Series Processor</b>							
UCS-CPU-I8280M	2.7	205	38.50	28	3 x 10.4	2933	2nd Gen Intel® Xeon®
UCS-CPU-I8280L	2.7	205	38.50	28	3 x 10.4	2933	2nd Gen Intel® Xeon®
UCS-CPU-I8280	2.7	205	38.50	28	3 x 10.4	2933	2nd Gen Intel® Xeon®
UCS-CPU-I8276M	2.2	165	38.50	28	3 x 10.4	2933	2nd Gen Intel® Xeon®
UCS-CPU-I8276L	2.2	165	38.50	28	3 x 10.4	2933	2nd Gen Intel® Xeon®
UCS-CPU-I8276	2.2	165	38.50	28	3 x 10.4	2933	2nd Gen Intel® Xeon®
UCS-CPU-I8270	2.7	205	35.75	26	3 x 10.4	2933	2nd Gen Intel® Xeon®
UCS-CPU-I8268	2.9	205	35.75	24	3 x 10.4	2933	2nd Gen Intel® Xeon®
UCS-CPU-I8260Y	2.4	165	35.75	24/20/16	3 x 10.4	2933	2nd Gen Intel® Xeon®
UCS-CPU-I8260M	2.4	165	35.75	24	3 x 10.4	2933	2nd Gen Intel® Xeon®
UCS-CPU-I8260L	2.3	165	35.75	24	3 x 10.4	2933	2nd Gen Intel® Xeon®
UCS-CPU-I8260	2.4	165	35.75	24	3 x 10.4	2933	2nd Gen Intel® Xeon®
UCS-CPU-I8253	2.2	125	22.00	16	3 x 10.4	2933	2nd Gen Intel® Xeon®
UCS-CPU-8180M	2.5	205	38.50	28	3 x 10.4	2666	Intel® Xeon®
UCS-CPU-8176M	2.1	165	38.50	28	3 x 10.4	2666	Intel® Xeon®
UCS-CPU-8170M	2.1	165	35.75	26	3 x 10.4	2666	Intel® Xeon®

Table 3 Available CPUs (*continued*)

Product ID (PID) <sup>1</sup>	Clock Freq (GHz)	Power (W)	Cache Size (MB)	Cores	UPI <sup>2</sup> Links (GT/s)	Highest DDR4 DIMM Clock Support (MHz) <sup>3</sup>	Workload
UCS-CPU-8160M	2.1	150	33.00	24	3 x 10.4	2666	Intel® Xeon®
UCS-CPU-8180	2.5	205	38.50	28	3 x 10.4	2666	Intel® Xeon®
UCS-CPU-8176	2.1	165	38.50	28	3 x 10.4	2666	Intel® Xeon®
UCS-CPU-8170	2.1	165	35.75	26	3 x 10.4	2666	Intel® Xeon®
UCS-CPU-8168	2.7	205	33.00	24	3 x 10.4	2666	Intel® Xeon®
UCS-CPU-8164	2.0	150	35.75	26	3 x 10.4	2666	Intel® Xeon®
UCS-CPU-8160	2.1	150	33.00	24	3 x 10.4	2666	Intel® Xeon®
UCS-CPU-8158	3.0	150	24.75	12	3 x 10.4	2666	Intel® Xeon®
UCS-CPU-8156	3.6	105	16.50	4	3 x 10.4	2666	Intel® Xeon®
UCS-CPU-8153	2.0	125	22.00	16	3 x 10.4	2666	Intel® Xeon®
<b>6000 Series Processor</b>							
UCS-CPU-I6262V	1.9	135	33.00	24	3 x 10.4	2400	2 <sup>nd</sup> Gen Intel® Xeon®
UCS-CPU-I6258R	2.7	205	35.75	28	2 x 10.4	2933	2 <sup>nd</sup> Gen Intel® Xeon®
UCS-CPU-I6254	3.1	200	24.75	18	3 x 10.4	2933	2 <sup>nd</sup> Gen Intel® Xeon®
UCS-CPU-I6252N	2.3	150	35.75	24	3 x 10.4	2933	2 <sup>nd</sup> Gen Intel® Xeon®
UCS-CPU-I6252	2.1	150	35.75	24	3 x 10.4	2933	2 <sup>nd</sup> Gen Intel® Xeon®
UCS-CPU-I6248R	3.0	205	35.75	24	2 x 10.4	2933	2 <sup>nd</sup> Gen Intel® Xeon®
UCS-CPU-I6248	2.5	150	27.50	20	3 x 10.4	2933	2 <sup>nd</sup> Gen Intel® Xeon®
UCS-CPU-I6246R	3.4	205	35.75	16	2 x 10.4	2933	2 <sup>nd</sup> Gen Intel® Xeon®
UCS-CPU-I6246	3.3	165	24.75	12	3 x 10.4	2933	2 <sup>nd</sup> Gen Intel® Xeon®
UCS-CPU-I6244	3.6	150	24.75	8	3 x 10.4	2933	2 <sup>nd</sup> Gen Intel® Xeon®
UCS-CPU-I6242R	3.1	205	35.75	20	2 x 10.4	2933	2 <sup>nd</sup> Gen Intel® Xeon®
UCS-CPU-I6242	2.8	150	22.00	16	3 x 10.4	2933	2 <sup>nd</sup> Gen Intel® Xeon®
UCS-CPU-I6240R	2.4	165	35.75	24	2 x 10.4	2933	2 <sup>nd</sup> Gen Intel® Xeon®
UCS-CPU-I6240Y	2.6	150	24.75	18/14/8	3 x 10.4	2933	2 <sup>nd</sup> Gen Intel® Xeon®
UCS-CPU-I6240M	2.6	150	24.75	18	3 x 10.4	2933	2 <sup>nd</sup> Gen Intel® Xeon®
UCS-CPU-I6240L	2.6	150	24.75	18	3 x 10.4	2933	2 <sup>nd</sup> Gen Intel® Xeon®
UCS-CPU-I6240	2.6	150	24.75	18	3 x 10.4	2933	2 <sup>nd</sup> Gen Intel® Xeon®
UCS-CPU-I6238R	2.2	165	38.50	28	2 x 10.4	2933	2 <sup>nd</sup> Gen Intel® Xeon®
UCS-CPU-I6238M	2.1	140	30.25	22	3 x 10.4	2933	2 <sup>nd</sup> Gen Intel® Xeon®
UCS-CPU-I6238L	2.1	140	30.25	22	3 x 10.4	2933	2 <sup>nd</sup> Gen Intel® Xeon®
UCS-CPU-I6238	2.1	140	30.25	22	3 x 10.4	2933	2 <sup>nd</sup> Gen Intel® Xeon®
UCS-CPU-I6234	3.3	130	24.75	8	3 x 10.4	2933	2 <sup>nd</sup> Gen Intel® Xeon®
UCS-CPU-I6230R	2.1	150	35.75	26	2 x 10.4	2933	2 <sup>nd</sup> Gen Intel® Xeon®

Table 3 Available CPUs (*continued*)

Product ID (PID) <sup>1</sup>	Clock Freq (GHz)	Power (W)	Cache Size (MB)	Cores	UPI <sup>2</sup> Links (GT/s)	Highest DDR4 DIMM Clock Support (MHz) <sup>3</sup>	Workload
UCS-CPU-I6230N	2.3	125	27.50	20	3 x 10.4	2933	2 <sup>nd</sup> Gen Intel® Xeon®
UCS-CPU-I6230	2.1	125	27.50	20	3 x 10.4	2933	2 <sup>nd</sup> Gen Intel® Xeon®
UCS-CPU-I6226R	2.8	150	22.00	16	2 x 10.4	2933	2 <sup>nd</sup> Gen Intel® Xeon®
UCS-CPU-I6226	2.7	125	19.25	12	3 x 10.4	2933	2 <sup>nd</sup> Gen Intel® Xeon®
UCS-CPU-I6222V	1.8	115	27.50	20	3 x 10.4	2400	2 <sup>nd</sup> Gen Intel® Xeon®
UCS-CPU-6142M	2.6	150	22.00	16	3 x 10.4	2666	Intel® Xeon®
UCS-CPU-6140M	2.3	140	24.75	18	3 x 10.4	2666	Intel® Xeon®
UCS-CPU-6134M	3.2	130	24.75	8	3 x 10.4	2666	Intel® Xeon®
UCS-CPU-6154	3.0	200	24.75	18	3 x 10.4	2666	Intel® Xeon®
UCS-CPU-6152	2.1	140	30.25	22	3 x 10.4	2666	Intel® Xeon®
UCS-CPU-6150	2.7	165	24.75	18	3 x 10.4	2666	Intel® Xeon®
UCS-CPU-6148	2.4	150	27.50	20	3 x 10.4	2666	Intel® Xeon®
UCS-CPU-6146	3.2	165	24.75	12	3 x 10.4	2666	Intel® Xeon®
UCS-CPU-6144	3.5	150	24.75	8	3 x 10.4	2666	Intel® Xeon®
UCS-CPU-6142	2.6	150	22.00	16	3 x 10.4	2666	Intel® Xeon®
UCS-CPU-6140	2.3	140	24.75	18	3 x 10.4	2666	Intel® Xeon®
UCS-CPU-6138	2.0	125	27.50	20	3 x 10.4	2666	Intel® Xeon®
UCS-CPU-6136	3.0	150	24.75	12	3 x 10.4	2666	Intel® Xeon®
UCS-CPU-6134	3.2	130	24.75	8	3 X 10.4	2666	Intel® Xeon®
UCS-CPU-6132	2.6	140	19.25	14	3 x 10.4	2666	Intel® Xeon®
UCS-CPU-6130	2.1	125	22.00	16	3 x 10.4	2666	Intel® Xeon®
UCS-CPU-6128	3.4	115	19.25	6	3 x 10.4	2666	Intel® Xeon®
UCS-CPU-6126	2.6	125	19.25	12	3 x 10.4	2666	Intel® Xeon®
<b>5000 Series Processor</b>							
UCS-CPU-I5222	3.8	125	16.50	4	2 x 10.4	2933	2 <sup>nd</sup> Gen Intel® Xeon®
UCS-CPU-I5220S	2.6	125	19.25	18	2 x 10.4	2666	2 <sup>nd</sup> Gen Intel® Xeon®
UCS-CPU-I5220R	2.2	150	35.75	24	2 x 10.4	2666	2 <sup>nd</sup> Gen Intel® Xeon®
UCS-CPU-I5220	2.2	125	24.75	18	2 x 10.4	2666	2 <sup>nd</sup> Gen Intel® Xeon®
UCS-CPU-I5218R	2.1	125	27.50	20	2 x 10.4	2666	2 <sup>nd</sup> Gen Intel® Xeon®
UCS-CPU-I5218B	2.3	125	22.00	16	2 x 10.4	2933	2 <sup>nd</sup> Gen Intel® Xeon®
UCS-CPU-I5218N	2.3	105	22.00	16	2 x 10.4	2666	2 <sup>nd</sup> Gen Intel® Xeon®
UCS-CPU-I5218	2.3	125	22.00	16	2 x 10.4	2666	2 <sup>nd</sup> Gen Intel® Xeon®
UCS-CPU-I5217	3.0	115	11.00	8	2 x 10.4	2666	2 <sup>nd</sup> Gen Intel® Xeon®
UCS-CPU-I5215M	2.5	85	13.75	10	2 x 10.4	2666	2 <sup>nd</sup> Gen Intel® Xeon®

Table 3 Available CPUs (*continued*)

Product ID (PID) <sup>1</sup>	Clock Freq (GHz)	Power (W)	Cache Size (MB)	Cores	UPI <sup>2</sup> Links (GT/s)	Highest DDR4 DIMM Clock Support (MHz) <sup>3</sup>	Workload
UCS-CPU-I5215L	2.5	85	13.75	10	2 x 10.4	2666	2 <sup>nd</sup> Gen Intel® Xeon®
UCS-CPU-I5215	2.5	85	13.75	10	2 x 10.4	2666	2 <sup>nd</sup> Gen Intel® Xeon®
UCS-CPU-5122	3.6	105	16.50	4	2 x 10.4	2666	Intel® Xeon®
UCS-CPU-5120	2.2	105	19.25	14	2 x 10.4	2400	Intel® Xeon®
UCS-CPU-5118	2.3	105	16.50	12	2 x 10.4	2400	Intel® Xeon®
UCS-CPU-5117	2.0	105	19.25	14	2 x 10.4	2400	Intel® Xeon®
UCS-CPU-5115	2.4	85	13.75	10	2 x 10.4	2400	Intel® Xeon®
<b>4000 Series Processor</b>							
UCS-CPU-I4216	2.1	100	22.00	16	2 x 9.6	2400	2 <sup>nd</sup> Gen Intel® Xeon®
UCS-CPU-I4215R	3.2	130	11.00	8	2 x 9.6	2400	2 <sup>nd</sup> Gen Intel® Xeon®
UCS-CPU-I4215	2.5	85	11.00	8	2 x 9.6	2400	2 <sup>nd</sup> Gen Intel® Xeon®
UCS-CPU-I4214Y	2.4	100	16.50	12	2 x 9.6	2400	2 <sup>nd</sup> Gen Intel® Xeon®
UCS-CPU-I4214R	2.2	105	16.75	12/10/8	2 x 9.6	2400	2 <sup>nd</sup> Gen Intel® Xeon®
UCS-CPU-I4214	2.2	85	16.75	12	2 x 9.6	2400	2 <sup>nd</sup> Gen Intel® Xeon®
UCS-CPU-I4210R	2.4	100	13.75	10	2 x 9.6	2400	2 <sup>nd</sup> Gen Intel® Xeon®
UCS-CPU-I4210	2.2	85	13.75	10	2 x 9.6	2400	2 <sup>nd</sup> Gen Intel® Xeon®
UCS-CPU-I4208	2.1	85	11.00	8	2 x 9.6	2400	2 <sup>nd</sup> Gen Intel® Xeon®
UCS-CPU-4116	2.1	85	16.50	12	2 x 9.6	2400	Intel® Xeon®
UCS-CPU-4114	2.2	85	13.75	10	2 x 9.6	2400	Intel® Xeon®
UCS-CPU-4112	2.6	85	8.25	4	2 x 9.6	2400	Intel® Xeon®
UCS-CPU-4110	2.1	85	11.00	8	2 x 9.6	2400	Intel® Xeon®
UCS-CPU-4108	1.8	85	11.00	8	2 x 9.6	2400	Intel® Xeon®
<b>3000 Series Processor</b>							
UCS-CPU-I3206R	1.9	85	11.00	8	2 x 9.6	2133	2 <sup>nd</sup> Gen Intel® Xeon®
UCS-CPU-I3204	1.9	85	8.25	6	2 x 9.6	2133	2 <sup>nd</sup> Gen Intel® Xeon®
UCS-CPU-3106	1.7	85	11.00	8	2 x 9.6	2133	Intel® Xeon®
UCS-CPU-3104	1.7	85	8.25	6	2 x 9.6	2133	Intel® Xeon®

**Notes:**

1. For additional details on ambient temperature limitation or configuration restrictions see [Table 3a Page on 15](#)
2. UPI = Ultra Path Interconnect
3. If higher or lower speed DIMMs are selected than what is shown in the table for a given CPU, the DIMMs will be clocked at the lowest common denominator of CPU clock and DIMM clock.
4. For details on memory support for processor classes and CPU modes, see [Memory Support for CPU Classes and CPU Modes on page 54](#)
5. For 2<sup>nd</sup> Generation Intel® Xeon® Scalable Processors, UCSM 4.0(4) software release is required.

The following table list ambient temperature limitation below 35°C [95°F] and configuration restrictions to ensure proper cooling and avoid excessive processor throttling, which may impact system performance.

Table 3a Ambient Temperature and Configuration Restrictions

Processor Thermal Design Power (TDP)	CPU PID	Blade Slot	Ambient Temperature Limitation	Configuration Restriction
Any Y or N SKUs	UCS-CPU-I8260Y UCS-CPU-I6252N UCS-CPU-I6240Y UCS-CPU-I6230N	Any	32°C [90°F]	Front Mezzanine GPU
200 W or 205W	UCS-CPU-I8280M UCS-CPU-I8280L UCS-CPU-I8280 UCS-CPU-I8270 UCS-CPU-I8268 UCS-CPU-8180M UCS-CPU-8180 UCS-CPU-8168 UCS-CPU-I6254 UCS-CPU-6154	Any		
High Freq With 150/165/125 W	UCS-CPU-I6246 UCS-CPU-I6244 UCS-CPU-I5222	Any		
205W R SKUs	UCS-CPU-I6258R UCS-CPU-I6248R UCS-CPU-6246R UCS-CPU-6242R	1 through 7		
205W R SKUs	UCS-CPU-I6258R	8	25°C [77°F]	
205W R SKUs	UCS-CPU-I6248R UCS-CPU-6246R UCS-CPU-6242R	8	22°C [72°F]	
 <b>CAUTION:</b>	<ul style="list-style-type: none"> <li>Systems configured with above processors need to adhere by the below ambient inlet temperature threshold, if not, a fan fault or executing workloads with extensive use of heavy instructions sets like Intel® Advanced Vector Extensions 512 (Intel® AVX-512), may assert thermal and/or performance faults with an associated event recorded in the System Event Log (SEL).</li> </ul>			

Supported Configurations

- (1) One-CPU Configuration

- Choose one CPU from any one of the rows of [Table 3 Available CPUs, page 9](#)

## (2) Two-CPU Configuration

- Choose two identical CPUs from any one of the rows of [Table 3 Available CPUs, page 9](#)



**NOTE:** See [CHOOSE MEMORY on page 16](#) for details on the compatibility of CPUs and DIMM speeds.

---

### STEP 3 CHOOSE MEMORY

The available memory for the B200 M5 is as follows:

- Clock speed: 2666 MHz or 2933 MHz depending on CPU type



**NOTE:** The compatibility of Intel® Xeon® scalable processor family CPUs and 2<sup>nd</sup> Generation Intel® Xeon® Scalable CPUs with different DIMM memory speeds and production servers is as shown below:

CPU Family	DIMM Speed (MHz)	Configuration
Intel Scalable CPUs	2666	2666 MHz DIMMs are supported for all production servers
	2933	2933 MHz DIMMs are not supported for new production servers
2 <sup>nd</sup> Gen Intel Scalable CPUs	2666	2666 MHz DIMMs are only supported when upgrading from Intel Scalable CPUs to 2 <sup>nd</sup> Gen Intel Scalable CPUs
	2933	2933 MHz is the only DIMM speed supported for new production servers

- Ranks per DIMM: 1, 2, 4, or 8
- Operational voltage: 1.2 V
- Registered ECC DDR4 DIMMS (RDIMMs), Load-reduced DIMMs (LRDIMMs), through-silicon via DIMMs (TSV DIMMs), or Intel® Persistent Memory Modules (PMEMs).

Memory is organized with six memory channels per CPU, with up to two DIMMs per channel, as shown in [Figure 3](#).



Figure 3 B200 M5 Memory Organization

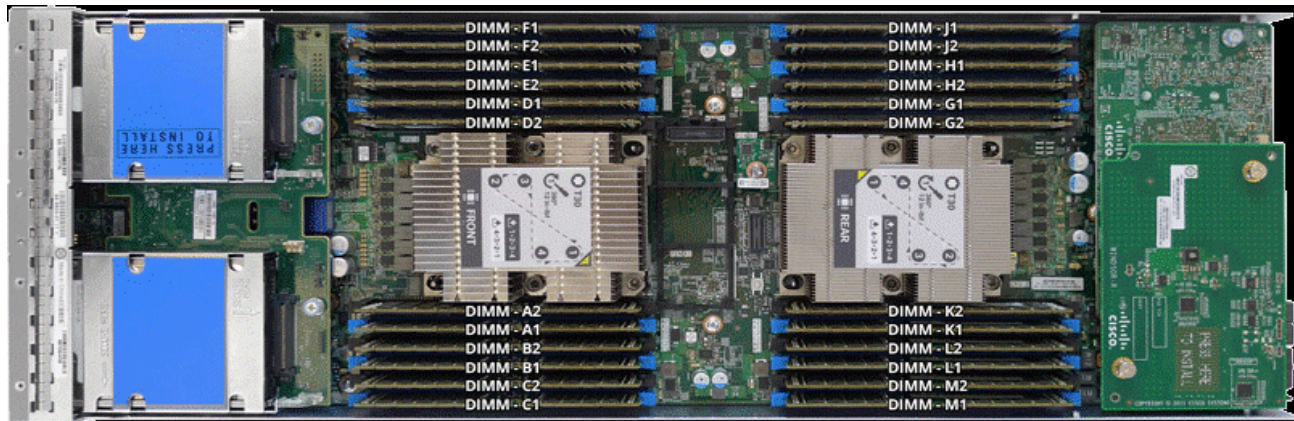

24 DIMMs, 6 Memory channels per CPU, up to 2 DIMMs per channel

### Choose DIMMs and Memory Mirroring

Select the memory configuration and whether or not you want the memory mirroring option. The supported memory DIMMs, PMEMs, PMEM Memory Mode, and the mirroring option are listed in [Table 4](#).

Table 4 Available DDR4 DIMMs and PMEMs

Product ID (PID)	PID Description	Voltage	Ranks /DIMM
<b>DIMMs</b>			
UCS-MR-128G8RS-H	128 GB DDR4-2666-MHz TSV-RDIMM/8R/x4	1.2 V	8
UCS-MR-X64G4RS-H	64 GB DDR4-2666-MHz TSV-RDIMM/4R/x4	1.2 V	4
UCS-ML-X64G4RS-H	64 GB DDR4-2666-MHz LRDIMM/4R/x4	1.2 V	4
UCS-MR-X32G2RS-H	32 GB DDR4-2666-MHz RDIMM/2R/x4	1.2 V	2
UCS-ML-X32G2RS-H	32 GB DDR4-2666-MHz LRDIMM/2R/x4	1.2 V	2
UCS-MR-X16G1RS-H	16 GB DDR4-2666-MHz RDIMM/1R/x4	1.2 V	1
UCS-ML-256G8RT-H <sup>1</sup>	256 GB DDR4-2933-MHz LRDIMM/8Rx4	1.2 V	
UCS-ML-128G4RT-H	128 GB DDR4-2933-MHz LRDIMM/4Rx4	1.2 V	4
UCS-ML-X64G4RT-H	64 GB DDR4-2933-MHz LRDIMM/4Rx4	1.2 V	4
UCS-MR-X64G2RT-H	64 GB DDR4-2933-MHz RDIMM/2Rx4	1.2 V	2
UCS-MR-X32G2RT-H	32 GB DDR4-2933-MHz RDIMM/2Rx4	1.2 V	2
UCS-MR-X16G1RT-H	16 GB DDR4-2933-MHz RDIMM/1Rx4	1.2 V	1
<b>Intel® Persistent Memory Product</b>			

Table 4 Available DDR4 DIMMs and PMEMs

Product ID (PID)	PID Description	Voltage	Ranks /DIMM
UCS-MP-128GS-A0	Intel® Persistent Memory, 128GB, 2666-MHz		
UCS-MP-256GS-A0	Intel® Persistent Memory, 256GB, 2666-MHz		
UCS-MP-512GS-A0	Intel® Persistent Memory, 512GB, 2666-MHz		
<b>Intel® Persistent Memory Product Operational Modes</b>			
UCS-DCPMM-AD	App Direct Mode		
UCS-DCPMM-MM	Memory Mode		
<b>Memory Mirroring Option<sup>2</sup></b>			
N01-MMIRROR	Memory mirroring option		

**Notes:**

1. The UCS-ML-256G8RT-H LRDIMM can be used only with 2nd Generation Intel® Xeon® scalable processor family CPUs, not with Intel® Xeon® scalable processor family CPUs.
2. For Memory Configuration and Mirroring, please refer to [Memory Configuration and Mirroring on page 51](#) and [Memory Support for CPU Classes and CPU Modes on page 54](#).

## Memory Configurations Features and Modes

System speed is dependent on the CPU DIMM speed support. Refer to [Available CPUs on page 9](#) for DIMM speeds.

- The B200 M5 server supports the following memory reliability, availability, and serviceability (RAS) modes:
  - Independent Channel Mode
  - Mirrored Channel Mode
- Below are the system level RAS Mode combination limitations:
  - Mixing of Independent and Lockstep channel mode is not allowed per platform.
  - Mixing of Non-Mirrored and Mirrored mode is not allowed per platform.
  - Mixing of Lockstep and Mirrored mode is not allowed per platform.
  - Do not mix RDIMMs, LRDIMMs, or TSV-RDIMMs.
  - Single-rank DIMMs can be mixed with dual-rank DIMMs in the same channel
- For best performance, observe the following:
  - DIMMs with different timing parameters can be installed on different slots within the same channel, but only timings that support the slowest DIMM will be applied to all. As a consequence, faster DIMMs will be operated at timings supported by the slowest DIMM populated.
  - When one DIMM is used, it must be populated in DIMM slot 1 (farthest away from the CPU) of a given channel.

- When single- or dual-rank DIMMs are populated in two DIMMs per channel (2DPC) configurations, always populate the higher number rank DIMM first (starting from the farthest slot). For a 2DPC example, first populate with dual-rank DIMMs in DIMM slot 1. Then populate single-rank DIMMs in DIMM 2 slot.
- DIMMs for CPU 1 and CPU 2 (when populated) must always be configured identically.
- Cisco memory from previous generation servers (DDR3 and DDR4) is not compatible with the UCS B200 M5 Blade.
- Memory can be configured in any number of DIMMs as pairs, although for optimal performance, see the document at the following link:  
<https://www.cisco.com/c/dam/en/us/products/collateral/servers-unified-computing/ucs-c-series-rack-servers/memory-guide-c220-c240-b200-m5.pdf>.
- For additional information, refer to *Memory Configuration and Mirroring on page 51*.
- For detailed Intel PMEM configurations, refer to the [Cisco UCS B200 M5 Server Installation Guide](#)

See [Table 5](#) and [Table 6](#) for information on DIMM speeds with Intel Scalable Processors.

Table 5 2933-MHz DIMM Memory Speeds with 2<sup>nd</sup> Generation Intel® Xeon® Scalable Processors

DIMM and CPU Frequencies (MHz)	DPC	LRDIMM (4Rx4)-128 GB (MHz)	LRDIMM (4Rx4) - 64 GB (MHz)	RDIMM (2Rx4) - 64 GB (MHz)	RDIMM (2Rx4) - 32 GB (MHz)	RDIMM (1Rx4) - 16 GB (MHz)
		1.2 V	1.2 V	1.2 V	1.2 V	1.2 V
DIMM = 2933 CPU = 2933	1DPC	2933	2933	2933	2933	2933
	2DPC	2933	2933	2933	2933	2933
DIMM = 2933 CPU = 2666	1DPC	2666	2666	2666	2666	2666
	2DPC	2666	2666	2666	2666	2666
DIMM = 2933 CPU = 2400	1DPC	2400	2400	2400	2400	2400
	2DPC	2400	2400	2400	2400	2400
DIMM = 2933 CPU = 2133	1DPC	2133	2133	2133	2133	2133
	2DPC	2133	2133	2133	2133	2133

Table 6 2666-MHz DIMM Memory Speeds with Intel® Xeon® Scalable Processors

DIMM and CPU Frequencies (MHz)	DPC	TSV-RDIMM (8Rx4) - 128 GB (MHz)	TSV-RDIMM (4Rx4) - 64 GB (MHz)	LRDIMM (4Rx4) - 64 GB (MHz)	RDIMM (2Rx4) - 32 GB (MHz)	LRDIMM (2Rx4) - 32 GB (MHz)
		1.2 V	1.2 V	1.2 V	1.2 V	1.2 V
DIMM = 2666 CPU = 2666	1DPC	2666	2666	2666	2666	2666
	2DPC	2666	2666	2666	2666	2666
DIMM = 2666 CPU = 2400	1DPC	2400	2400	2400	2400	2400
	2DPC	2400	2400	2400	2400	2400
DIMM = 2666 CPU = 2133	1DPC	2133	2133	2133	2133	2133
	2DPC	2133	2133	2133	2133	2133

See [Table 7](#) for DCCPM memory modes.

Table 7 Intel® Persistent Memory Modes

Intel® Persistent Memory Modes	
App Direct Mode:	PMEM operates as a solid-state disk storage device. Data is saved and is non-volatile. Both PMEM and DIMM capacity counts towards CPU tiering (both PMEM and DIMM capacities count towards the CPU capacity limit)
Memory Mode: <sup>1</sup>	PMEM operates as a 100% memory module. Data is volatile and DRAM acts as a cache for PMEMs. Only PMEM capacity counts towards CPU tiering (only the PMEM capacity counts towards the CPU capacity limit). This is the factory default mode.
Mix Mode:	DRAM as cache. Only PMEM capacity counts towards CPU tiering (only the PMEM capacity counts towards the CPU capacity limit).

**Notes:**

1. For Memory Mode, the Intel-recommended DIMM to PMEM capacity ratio in the same CPU channel is from 1:4 to 1:16. So if you use a 128 GB DIMM in a channel, you could use a 512 GB PMEM for a 1:4 capacity ratio. If you use a 32 GB DIMM in a channel, you could use a 512 GB PMEM for a 1:16 capacity ratio. There are several other combinations possible

See [Table 8](#) for how to populate combinations of DIMMs and PMEMs.

**Table 8 2<sup>nd</sup> Generation Intel® Xeon® Scalable Processor DIMM and PMEM<sup>1</sup> Physical Configurations (dual socket)**

DIMM to PMEM Count	CPU 1											
	iMC1						iMCO					
	Channel 2		Channel 1		Channel 0		Channel 2		Channel 1		Channel 0	
	F2	F1	E2	E1	D2	D1	C2	C1	B2	B1	A2	A1
6 to 2		DIMM		DIMM	PMEM	DIMM		DIMM		DIMM	PMEM	DIMM
6 to 4		DIMM	PMEM	DIMM	PMEM	DIMM		DIMM	PMEM	DIMM	PMEM	DIMM
6 to 6	PMEM	DIMM	PMEM	DIMM	PMEM	DIMM	PMEM	DIMM	PMEM	DIMM	PMEM	DIMM
DIMM to PMEM Count	CPU 2											
	iMC1						iMCO					
	Channel 2		Channel 1		Channel 0		Channel 2		Channel 1		Channel 0	
	M2	M1	L2	L1	K2	K1	J2	J1	H2	H1	G2	G1
6 to 2		DIMM		DIMM	PMEM	DIMM		DIMM		DIMM	PMEM	DIMM
6 to 4		DIMM	PMEM	DIMM	PMEM	DIMM		DIMM	PMEM	DIMM	PMEM	DIMM
6 to 6	PMEM	DIMM	PMEM	DIMM	PMEM	DIMM	PMEM	DIMM	PMEM	DIMM	PMEM	DIMM

**Notes:**

1. All systems must be fully populated with two CPUs when using PMEMs at this time.



**NOTE:** There are three possible memory configurations for each CPU when combining DIMMs and PMEMs, and the configurations must be the same for each CPU:

- 6 DIMMs and 2 PMEMs, or
- 6 DIMMs and 4 PMEMs, or
- 6 DIMMs and 6 PMEMs

For detailed Intel PMEM configurations, refer to

[Cisco UCS B200 M5 Server Installation Guide](#)

For detailed DIMM/PMEM informations, refer to

[Cisco UCS C220/C240/B200 M5 Memory Guide](#)

## STEP 4 CHOOSE MLOM ADAPTER

The UCS B200 M5 must be ordered with a Cisco VIC mLOM Adapter. The adapter can operate in a single-CPU or dual-CPU configuration. [Table 10](#) shows available mLOM adapter choices.

Table 9 mLOM Adapters

Product ID (PID)	Description	Connection type
UCSB-MLOM-40G-04	Cisco UCS VIC 1440 modular LOM for blade servers	mLOM
UCSB-MLOM-40G-03	Cisco UCS VIC 1340 modular LOM for blade servers	mLOM

Table 10 Aggregate Bandwidth with mLOM Only configuration

mLOM Only	Fabrics Extenders in UCS 5108 blade chassis Aggregate Bandwidth (Gb/s)				Fabric Interconnects Support				
	2x 2408	2x 2304	2x2208XP	2x 2204XP	2 x 62xx	2 x 6324	2 x 6332	2 x 6332-16UP	2 x 6454
VIC 1440 mLOM	40 <sup>1</sup>	40 <sup>1</sup>	40 <sup>1</sup>	20	Yes	Yes (20 Gb/s)	Yes	Yes	Yes
VIC 1340 mLOM	40 <sup>1</sup>	40 <sup>1</sup>	40 <sup>1</sup>	20	Yes	Yes (20 Gb/s)	Yes	Yes	Yes

**Notes:**

1. These configurations implement two 2x10 Gbps port-channels

Cisco developed 1300 and 1400 Series Virtual Interface Cards (VICs) to provide flexibility to create multiple NIC and HBA devices. The VIC features are listed here:

- VICs include enhancements including network overlay offload support.
- Two Converged Network Adapter (CNA) ports, supporting both Ethernet and FCoE
- Delivers up to 80 Gbps total I/O throughput to the server
- VIC supports either max dual 4x10Gbps Unified I/O ports or 2x40 (native) Gbps Unified I/O ports
- Supports up to 256 fully functional unique and independent PCIe adapters and interfaces
- Provides virtual machine visibility from the physical network and a consistent network operations model for physical and virtual servers
- Supports customer requirements for a wide range of operating systems and hypervisors

The mLOM VIC on the UCS B200 M5 enables connectivity to the Fabric Interconnect either through the Fabric Extender (FEX) or directly using the UCS 6324 Fabric Connector (UCS Mini) on the UCS 5108 Blade Chassis.

The supported Fabric Extenders for the B200 M5 blades are

- Cisco UCS 2408 Fabric Extender
- Cisco UCS 2208XP Fabric Extender
- Cisco UCS 2204XP Fabric Extender
- Cisco UCS 2304 Fabric Extender

The supported Fabric Interconnects for the B200 M5 blades are

- Cisco UCS 6248UP Fabric Interconnect
- Cisco UCS 6296UP Fabric Interconnect
- Cisco UCS 6332 Fabric Interconnect
- Cisco UCS 6332-16UP Fabric Interconnect
- Cisco UCS 6454 Fabric Interconnect

The recommended UCS Manager (UCSM) release for the B200 M5 is UCSM 3.2(2), due to support of higher wattage CPUs. The Cisco UCS 6454 Fabric Interconnect and/or VIC 1440 requires UCSM 4.0(1) or greater.

## STEP 5 CHOOSE SOFTWARE

A UCSM software version needs to be selected for the standalone UCS B200 M5 Blade PID (UCSB-B200-M5-UPG).



**NOTE:**

- This is a new mandatory option for standalone blades starting with the UCS B200 M5.
- When the UCS B200 M5 is configured inside of a chassis in the CCW ordering tool, the UCSM software version is selected at the chassis level. The software option will not be available under the UCS B200 M5 in that case.
- The recommended UCS releases for the UCS B200 M5 are UCSM 3.2(2) and UCSM 4.0. These releases support higher wattage CPUs. FI 6454 and/or VIC 1400 require release UCSM 4.0(1) or greater.

Choose one software PID from [Table 11](#).

Table 11 Available UCSM Software

Product ID (PID)	Product Description	Software Version
N20-FW016	UCS 5108 Blade Chassis FW Package 4.0	UCSM 4.0
N20-FW017	UCS 5108 Blade Chassis FW Package 4.1	UCSM 4.1



## STEP 6 CHOOSE OPTIONAL REAR MEZZANINE ADAPTERS (VIC, NVMe or GPU)

The UCS B200 M5 has one rear mezzanine adapter connector. The UCS B200 M5 can be ordered with or without a rear mezzanine adapter. Refer to [Table 12 Available Rear Mezzanine Adapters](#) for supported adapters.

Table 12 Available Rear Mezzanine Adapters

Product ID(PID)	PID Description	CPUs Required	Connector Type
<b>Port Expander Card for VIC</b>			
This is a hardware option to enable an additional 4 ports of the VIC 1340, bringing the total capability of the VIC 1340 to a dual native 40G interface or a dual 4 x 10 GbE port-channelled interface, respectively.			
UCSB-MLOM-PT-01	Cisco UCS Port Expander Card for VIC	1 or 2 CPUs	Rear Mezzanine
<b>Cisco VIC Card</b>			
UCSB-VIC-M84-4P	Cisco UCS VIC 1480 mezzanine adapter	2 CPUs required	Rear Mezzanine
UCSB-VIC-M83-8P	Cisco UCS VIC 1380 mezzanine adapter	2 CPUs required	Rear Mezzanine
<b>Cisco NVMe Flash Storage Adapters</b>			
UCSB-F-H-5607	UCS Blade PCIe/NVMe Storage Mezz 560 GB High Endurance	2 CPUs required	Rear Mezzanine
UCSB-F-H-32003	UCS Blade PCIe/NVMe Storage Mezz 3200 GB Medium Endurance	2 CPUs required	Rear Mezzanine
<b>Cisco GPU Rear</b>			
UCSB-GPU-P6-R <sup>1</sup>	NVIDIA GRID P6 Rear Mezzanine	2 CPUs required	Rear Mezzanine

### Notes:

1. For GPU P6, maximum cards per node supported is two.

### Supported Configurations

- Requires an mLOM (either VIC 1340 or VIC 1440)
- You cannot mix a 1340 with a 1480 or a 1440 and a 1380)

See [Table 13](#) for aggregate bandwidths with various rear mezzanine cards installed.

Table 13 Aggregate Bandwidth with Rear Mezzanine Cards Installed

Rear Mezz Adapter	IO Modules in UCS5108 blade chassis Aggregate Bandwidth (Gb/s)				Fabric Interconnects Support				
	2x 2408	2x 2304	2x 2208XP	2x 2204XP	2 x 62xx	2 x 6324	2 x 6332	2 x 6332-16UP	2 x 6454
Port Expander+ VIC 1340	80 <sup>2</sup>	80 <sup>1</sup>	80 <sup>2</sup>	40 <sup>3</sup>	Yes	Yes (40Gbps)	Yes	Yes	Yes
Port Expander + VIC 1440	80 <sup>4</sup>	80 <sup>1.5</sup>	Not Supported	Not Supported	Yes	No	Yes	Yes	No
VIC 1380 mezz	80 <sup>6</sup>	80 <sup>6</sup>	80 <sup>6</sup>	40	Yes	Yes (40Gbps)	Yes	Yes	Yes
VIC 1480 mezz	80 <sup>6</sup>	80 <sup>6</sup>	80 <sup>6</sup>	40	Yes	Yes (40Gbps)	Yes	Yes	Yes
Flash Card	40 <sup>3</sup>	40 <sup>3</sup>	40 <sup>3</sup>	20	Yes	Yes (20Gbps)	Yes	Yes	Yes
GPU	40 <sup>3</sup>	40 <sup>3</sup>	40 <sup>3</sup>	20	Yes	Yes (20Gbps)	Yes	Yes	Yes

Notes:

1. Uses a dual native 40G interface
2. Two 4x10Gbps port-channelled
3. Two 2x10Gbps port-channelled
4. Supported starting with UCSM 4.1(2). The maximum single-flow is 25 Gbps with an aggregate of 40 Gbps. To avoid IOM/Fabric Extender transient drops due to a speed mismatch of 40 Gbps towards the server and 25 Gbps towards the fabric interconnect (FI), vNIC rate-limiting to 25 Gbps is recommended.
5. If operating in 4x10 mode, bandwidth drops down to 40Gbps (two 2x10 G port-channelled)
6. Four 2x10 Gbps port-channelled

## STEP 7 CHOOSE OPTIONAL FRONT MEZZANINE ADAPTER

The UCS B200 M5 has one front mezzanine connector that can accommodate a storage controller with bays for NVMe drives or a GPU. The UCS B200 M5 can be ordered with or without the front mezzanine adapter. Refer to [Table 14 Available Front Mezzanine Adapters](#).



**NOTE:** A front GPU cannot be used with CPUs that dissipate equal to or greater than 165 W.

Table 14 Available Front Mezzanine Adapters

Product ID(PID)	PID Description	Connector Type
<b>Storage Controller<sup>1</sup> (required for installing local drives in the UCS B200 M5)</b>		
UCSB-MRAID12G <sup>2, 3</sup>	Cisco FlexStorage 12G SAS RAID controller with drive bays	Front Mezzanine
UCSB-MRAID12G-HE <sup>4, 3</sup>	Cisco FlexStorage 12G SAS RAID controller with 2 GB flash-backed write cache with drive bays	Front Mezzanine
UCSB-LSTOR-PT <sup>5</sup>	Cisco FlexStorage NVMe Passthrough module with HDD cage	Front Mezzanine
UCSB-LSTOR-BK <sup>6</sup>	Cisco FlexStorage blanking panel without controller or drive bays	Drive Blank
<b>Cisco GPU Front</b>		
UCSB-GPU-P6-F <sup>7</sup>	NVIDIA GRID P6 Front Mezzanine	Front Mezzanine

### Notes:

1. A Storage Controller is required for installing local drives (HDD, SSD, NVMe) on the B200 M5.
2. For hard disk drives (HDDs) or solid-state drives (SSDs), a Cisco FlexStorage 12G SAS RAID Controller is required.
3. The Cisco FlexStorage 12G SAS RAID Controller is based on the LSI 3108 ROC and runs the iMegaRAID software stack. It provides 12 Gbps RAID functionality for SAS/SATA SSD/HDD and has RAID 0, 1 and JBOD support. If supercapacitor needs to be replaced, it can be done so by ordering UCSB-MRAID-SC=. See Installation Document for instructions.
4. The Cisco FlexStorage 12G SAS RAID controller with 2 GB Flash-backed write cache is based on the LSI 3108 ROC and runs the LSI MegaRAID software stack. It provides 12 Gbps RAID Functionality for SAS/SATA HDD/SSD and has RAID 0, 1, 5 and 6 Support. If supercapacitor needs to be replaced, it can be done so by ordering UCSB-MRAID-SC=. See Installation Document for instructions

The flash-backed write cache provides RAID controller cache protection using NAND flash memory and a supercapacitor. In the event of a power or server failure, cached data is automatically transferred from the RAID controller DRAM write cache to flash. Once power is restored, the data in the NAND flash is copied back into the DRAM write cache until it can be flushed to the disk drives.

5. For NVMe, the Cisco FlexStorage NVMe Passthrough module is required.

6. For servers that do not need local storage, and where no storage controllers are included, storage blanking panels are auto-included as a part of the ordering configuration rules. In order for the UCS B200 M5 to function properly and not overheat, drive blanks must be installed if no storage controller or GPU is used.
7. For GPU P6, maximum cards per node supported is two

## STEP 8 CHOOSE OPTIONAL DRIVES

The UCS B200 M5 can be ordered with or without drives. The standard drive features are:

- 2.5-inch small form factor
- Hot-pluggable
- Sled-mounted
- The B200 M5 supports hard disk drives (HDD), Solid State Drives (SSD) or Non-Volatile Memory Express (NVMe) Drives
- One or two drives can be selected
- Drives always require one storage controller listed in [Table 14 Available Front Mezzanine Adapters, page 27](#).

Select one or two drives from the list of supported drives available in [Table 15](#).

Table 15 Available Drive Options

Product ID (PID)	Description	Drive Type	Speed	Performance /Endurance /Value	Size
<b>HDD<sup>1</sup></b>					
UCS-HD900G15K12G	900 GB 12G SAS 15K RPM SFF HDD	SAS	15K RPM	N/A	900 GB
UCS-HD600G15K12G	600 GB 12G SAS 15K RPM SFF HDD	SAS	15K RPM	N/A	600 GB
UCS-HD300G15K12G	300 GB 12G SAS 15K RPM SFF HDD	SAS	15K RPM	N/A	300 GB
UCS-HD24TB10KS4K	2.4 TB 12G SAS 10K RPM SFF HDD (4K) <sup>2</sup>	SAS	10K RPM	N/A	2400 GB
UCS-HD18TB10KS4K	1.8 TB 12G SAS 10K RPM SFF HDD (4K) <sup>2</sup>	SAS	10K RPM	N/A	1800 GB
UCS-HD12TB10K12G	1.2 TB 12G SAS 10K RPM SFF HDD	SAS	10K RPM	N/A	1200 GB
UCS-HD600G10K12G	600 GB 12G SAS 10K RPM SFF HDD	SAS	10K RPM	N/A	600 GB
UCS-HD300G10K12G	300 GB 12G SAS 10K RPM SFF HDD	SAS	10K RPM	N/A	300 GB

Table 15 Available Drive Options (*continued*)

Product ID (PID)	Description	Drive Type	Speed	Performance /Endurance /Value	Size
<b>SSD<sup>1</sup></b>					
<b>Enterprise Performance SSDs (high endurance, supports up to 10X or 3X DWPD (drive writes per day))</b>					
UCS-SD800G12S4-EP	800 GB 2.5 inch Ent. Performance 12G SAS SSD (10X endurance) (Samsung 1635)	SAS	12G	Ent. Perf 10X	800 GB
UCS-SD16TB12S4-EP	1.6 TB 2.5 inch Ent. Performance 12G SAS SSD (10X endurance) (SanDisk Lightning II)	SAS	12G	Ent. Perf 10X	1600 GB
UCS-SD800GSAS3-EP	800 GB 2.5 inch Enterprise performance 12G SAS SSD(3X endurance) (Toshiba PX05)	SAS	12G	Ent. Perf 3X	800 GB
UCS-SD16TSASS3-EP	1.6 TB 2.5 inch Enterprise performance 12G SAS SSD(3X endurance) (Toshiba PX05)	SAS	12G	Ent. Perf 3X	1600 GB
UCS-SD400GH3-EP	400 GB 2.5 inch Enterprise performance 12G SAS SSD (3X DWPD)	SAS	12G	Ent. Perf 3X	400 GB
UCS-SD800GH3-EP	800 GB 2.5 inch Enterprise performance 12G SAS SSD (3X DWPD)	SAS	12G	Ent. Perf 3X	800 GB
UCS-SD16TH3-EP	1.6 TB 2.5 inch Enterprise performance 12G SAS SSD (3X DWPD)	SAS	12G	Ent. Perf 3X	1600 GB
UCS-SD32TH3-EP	3.2 TB 2.5in Enterprise performance 12G SAS SSD (3X DWPD)	SAS	12G	Ent. Perf 3X	3200 GB
UCS-SD480GIS3-EP	480 GB 2.5in Enterprise performance 6G SATA SSD(3X endurance)	SATA	6G	Ent. Perf 3X	480 GB
UCS-SD960GIS3-EP	960 GB 2.5in Enterprise performance 6G SATA SSD(3X endurance)	SATA	6G	Ent. Perf 3X	960 GB
UCS-SD19TIS3-EP	1.9 TB 2.5in Enterprise performance 6G SATA SSD(3X endurance)	SATA	6G	Ent. Perf 3X	1900 GB
UCS-SD480GMB3X-EP	480 GB 2.5in Enterprise performance 6G SATA SSD(3X endurance)	SATA	6G	Ent. Perf 3X	480 GB

Table 15 Available Drive Options (*continued*)

Product ID (PID)	Description	Drive Type	Speed	Performance /Endurance /Value	Size
UCS-SD960GMB3X-EP	960 GB 2.5in Enterprise performance 6GSATA SSD(3X endurance)	SATA	6G	Ent. Perf 3X	960 GB
UCS-SD19TMB3X-EP	1.9 TB 2.5in Enterprise performance 6GSATA SSD(3X endurance)	SATA	6G	Ent. Perf 3X	1900 GB
<b>Enterprise Value SSDs (Low endurance, supports up to 1X DWPD (drive writes per day))</b>					
UCS-SD480GSAS-EV	480 GB 2.5 inch Enterprise Value 12G SAS SSD (Toshiba PX05)	SAS	12G	Ent. Value	480 GB
UCS-SD960GSAS-EV	960 GB 2.5 inch Enterprise Value 12G SAS SSD (Toshiba PX05)	SAS	12G	Ent. Value	960 GB
UCS-SD38TSAS-EV	3.8 TB 2.5 inch Enterprise Value 12G SAS SSD (Toshiba PX05)	SAS	12G	Ent. Value	3800 GB
UCS-SD19TSAS-EV	1.9 TB 2.5 inch Enterprise Value 12G SAS SSD	SAS	12G	Ent. Value	1900 GB
UCS-SD480GH1-EV	480 GB 2.5 inch Enterprise Value 12G SAS SSD (1X endurance)	SAS	12G	Ent. Value	480 GB
UCS-SD960GH1-EV	960 GB 2.5 inch Enterprise Value 12G SAS SSD (1X endurance)	SAS	12G	Ent. Value	960 GB
UCS-SD19TH1-EV	1.9 TB 2.5 inch Enterprise Value 12G SAS SSD (1X endurance)	SAS	12G	Ent. Value	1900 GB
UCS-SD38TH1-EV	3.8 TB 2.5 inch Enterprise Value 12G SAS SSD (1X endurance)	SAS	12G	Ent. Value	3800 GB
UCS-SD960GBKS4-EV	960 GB 2.5 inch Enterprise Value 6G SATA SSD (Samsung PM863A/PM883)	SATA	6G	Ent. Value	960 GB
UCS-SD38TBKS4-EV	3.8 TB 2.5 inch Enterprise Value 6G SATA SSD (Samsung PM863A/PM883)	SATA	6G	Ent. Value	3800 GB
UCS-SD120GBMS4-EV	120 GB 2.5 inch Enterprise Value 6G SATA SSD (Micron 5100/5200)	SATA	6G	Ent. Value	120 GB
UCS-SD240GBMS4-EV	240 GB 2.5 inch Enterprise Value 6G SATA SSD (Micron 5100/5200)	SATA	6G	Ent. Value	240 GB
UCS-SD480GBMS4-EV	480 GB 2.5 inch Enterprise Value 6G SATA SSD (Micron 5100/5200)	SATA	6G	Ent. Value	480 GB
UCS-SD960GBMS4-EV	960 GB 2.5 inch Enterprise Value 6G SATA SSD (Micron 5100/5200)	SATA	6G	Ent. Value	960 GB

Table 15 Available Drive Options (*continued*)

Product ID (PID)	Description	Drive Type	Speed	Performance /Endurance /Value	Size
UCS-SD16TBMS4-EV	1.6 TB 2.5 inch Enterprise Value 6G SATA SSD (Micron 5100/5200)	SATA	6G	Ent. Value	1600 GB
UCS-SD19TBMS4-EV	1.9 TB 2.5 inch Enterprise Value 6G SATA SSD (Micron 5100/5200)	SATA	6G	Ent. Value	1900 GB
UCS-SD38TBMS4-EV	3.8 TB 2.5 inch Enterprise Value 6G SATA SSD (Micron 5100/5200)	SATA	6G	Ent. Value	3800 GB
UCS-SD76T61X-EV	7.6 TB 2.5 inch Enterprise Value 6G SATA SSD	SATA	6G	Ent. Value	7600 GB
UCS-SD76TBMS4-EV	7.6 TB 2.5 inch Enterprise Value 6G SATA SSD (Micron 5100/5200)	SATA	6G	Ent. Value	7600 GB
UCS-SD480GBIS6-EV	480 GB 2.5 inch Enterprise Value 6G SATA SSD (Intel S4500/S4150)	SATA	6G	Ent. Value	480 GB
UCS-SD960GBIS6-EV	960 GB 2.5 inch Enterprise Value 6G SATA SSD (Intel S4500/S4150)	SATA	6G	Ent. Value	960 GB
UCS-SD38TBIS6-EV	3.8 TB 2.5 inch Enterprise Value 6G SATA SSD (Intel S4500/S4150)	SATA	6G	Ent. Value	3800 GB
<b>Self-Encrypted Drives (SEDs)</b>					
UCS-SD480G2HBNK9	480GB Enterprise value SAS SSD (1X FWPD, SED) FIPS 140-2	SAS		Ent. Value	480 GB
UCS-SD960GBHBNK9	960 GB Enterprise value SAS SSD (1X FWPD, SED) FIPS 140-2	SAS		Ent. Value	960 GB
UCS-SD38T2HBNK9	3.8TB Enterprise value SAS SSD (1X FWPD, SED)FIPS 140-2	SAS		Ent. Value	3.8 TB
UCS-HD600G15K9	600 GB 12G SAS 15K RPM SFF HDD (SED)FIPS 140-2	SAS	15K RPM	N/A	600 GB
UCS-HD12G10K9	1.2 TB 12G SAS 10K RPM SFF HDD (SED) FIPS 140-2	SAS	10K RPM	N/A	1200 GB
UCS-HD18G10K9	1.8 TB 12G SAS 10K RPM SFF HDD (4K format, SED)FIPS 140-2	SAS	10K RPM	N/A	1800 GB
UCS-HD24T10BNK9	2.4 TB 12G SAS 10K RPM SFF HDD (4K format, SED)FIPS 140-2	SAS	10K RPM	N/A	2400 GB



Table 15 Available Drive Options (*continued*)

Product ID (PID)	Description	Drive Type	Speed	Performance /Endurance /Value	Size
<b>NVMe<sup>3, 4, 5</sup></b>					
UCSB-NVMEHW-H800	Cisco 2.5" U.2 800 GB HGST SN200 NVMe High Perf. High Endurance	NVMe	High Perf	High Perf/High Endurance	800 GB
UCSB-NVMEHW-H1600	Cisco 2.5" U.2 1.6 TB HGST SN200 NVMe High Perf. High Endurance	NVMe	High Perf	High Perf/High Endurance	1600 GB
UCSB-NVMEHW-H3200	3.2TB 2.5in U.2 HGST SN200 NVMe High Perf. High Endurance	NVMe	High Perf	High Perf/High Endurance	3200 GB
UCSB-NVMEHW-H6400	Cisco 2.5" U.2 6.4 TB HGST SN200 NVMe High Perf. High Endurance	NVMe	High Perf	High Perf/High Endurance	6400 GB
UCSB-NVMEHW-H7680	Cisco 2.5" U.2 7.7 TB HGST SN200 NVMe High Perf. Value Endurance	NVMe	High Perf	High Perf/Value Endurance	7680 GB
UCSB-NVMEHW-I8000	Cisco 2.5" U.2 8TB Intel P4510 NVMe High Perf. Value Endurance	NVMe	High Perf	High Perf/Value Endurance	8000 GB
UCSB-NVMEXPB-I375	Cisco 2.5in U.2 375GB Intel P4800 NVMe Med. Perf	NVMe	Med Perf	Med Perf	375 GB
UCSB-NVMEXP-I750	750 GB 2.5in Intel Optane NVMe Extreme Perf	NVMe	Extrm Perf	Extreme Perf	750 GB
UCSB-NVME2H-I1000	Cisco 2.5" U.2 1,0 TB Intel P4510 NVMe High Perf. Value Endurance	NVMe	High Perf	High Perf/Value Endurance	1000 GB
UCSB-NVME2H-I1600	Cisco 2.5" U.2 1.6TB Intel P4610 NVMe High Perf. High Endurance	NVMe	High Perf	High Perf/High Endurance	1600 GB
UCSB-NVME2H-I2TBV	Cisco 2.5" U.2 2.0TB Intel P4510 NVMe High Perf. Value Endurance	NVMe	High Perf	High Perf/Value Endurance	2000 GB
UCSB-NVME2H-I3200	Cisco 2.5" U.2 3.2TB Intel P4610 NVMe High Perf. High Endurance	NVMe	High Perf	High Perf/High Endurance	3200 GB
UCSB-NVME2H-I4000	Cisco 2.5" U.2 4.0TB Intel P4510 NVMe High Perf. Value Endu	NVMe	High Perf	High Perf/Value Endurance	4000 GB

Notes:

1. HDDs and SSDs require either of the following storage controllers in the front mezzanine slot:  
UCSB-MRAID12G, or  
UCSB-MRAID12G-HE
2. For 4K native (4Kn) drives:  
VMWare ESXi 6.0 does not support 4Kn Drives. 4Kn drive support with VMWare is available in release 6.7 and later.  
4K native drives require UEFI Boot
3. NVMe drives require the following storage controller in the front mezzanine slot:  
UCSB-LSTOR-PT
4. For HDD or SSD drives to be in a RAID group, two identical HDDs or SSDs must be used in the group.
5. If HDD or SSD are in JBOD Mode, the drives do not need to be identical.



**NOTE:** Cisco uses solid state drives (SSDs) from a number of vendors. All solid state drives (SSDs) are subject to physical write limits and have varying maximum usage limitation specifications set by the manufacturer. Cisco will not replace any solid state drives (SSDs) that have exceeded any maximum usage specifications set by Cisco or the manufacturer, as determined solely by Cisco.

---

## STEP 9 CHOOSE OPTIONAL SECURE DIGITAL CARDS or M.2 DRIVES

A mini-storage module connector is provided on the motherboard.

For the UCS B200 M5, there are two kinds of mini-storage carriers that fit in the connector on the motherboard, although only one kind at a time can be selected with a single UCS B200 M5. The modules are:

- A carrier with two SD HC sockets that accommodate up to two SDHC devices
- A carrier with two M.2 sockets that accommodates up to two SATA M.2 devices



### NOTE:

- You cannot select both an SD carrier and an M.2 carrier; only one of the two can be selected.
- You can select 1 or 2 drives; two are required for mirroring.

Choose an SD mini storage carrier and one or two identical SD cards from [Table 16](#).

**Table 16 Available SD Card Options**

Product ID (PID)	Description	Mirroring
UCS-SD-128G	128 GB SD card module for UCS	Supported with dual module
UCS-SD-64G-S	64 GB SD card module for UCS	Supported with dual cards
UCS-SD-32G-S	32 GB SD card module for UCS	Supported with dual cards
UCS-MSTOR-SD <sup>1</sup>	Mini storage carrier (holds up to 2 SDs)	N/A

### Notes:

1. Auto included when an SD card is selected

Choose an M.2 mini storage carrier and one or two identical M.2 cards from [Table 16](#).

**Table 17 Available M.2 Options**

Product ID (PID)	Description	Mirroring
UCS-M2-240GB	240 GB SATA M.2	Supported via SW RAID on Intel PCH <sup>1</sup>
UCS-M2-960GB	960 GB SATA M.2	Supported via SW RAID on Intel PCH <sup>1</sup>
UCS-MSTOR-M2 <sup>2</sup>	M.2 mini storage carrier (holds up to 2 M.2s)	N/A

### Notes:

1. VMware does not support software RAID, so there are no mirroring options available with VMWare. However, an M.2 drive can still be used as a boot device
2. Auto included when an M.2 Drive is selected

### Cisco 6GB/s SATA Boot-Optimized M.2 RAID Controller

You can choose the Boot-Optimized RAID controller for Hardware RAID across the two internal SATA M.2 drives, which plugs in the mini-storage module socket on the motherboard.

**Note:** The Boot-Optimized RAID controller will support VMWare, Windows and Linux Operating Systems.

Table 18 Boot-Optimized RAID controller

Product ID (PID)	PID Description
UCS-M2-HWRAID	Cisco Boot optimized M.2 Raid controller



**NOTE:**

- This controller supports RAID 1 and JBOD mode
- The UCS-M2-HWRAID modular adapter is available only with 240 GB and 960 GB M.2 SSDs.
- (CIMC/UCSM) is supported for configuring of Volumes and monitoring of the controller and installed SATA M.2
- The minimum version of Cisco IMC and Cisco UCS Manager that support this controller is 4.0(4) and later. The name of the controller in the software is MSTOR-RAID
- The SATA M.2 drives can boot in UEFI mode only. Legacy boot mode is not supported
- Hot-plug replacement is not supported. The server must be powered off.
- Boot-Optimized M.2 RAID Controller Module is not supported when the server is used as a compute node in HyperFlex configurations.

## STEP 10 CHOOSE OPTIONAL TRUSTED PLATFORM MODULE

Trusted Platform Module (TPM) is a computer chip or microcontroller that can securely store artifacts used to authenticate the platform or server. These artifacts can include passwords, certificates, or encryption keys. A TPM can also be used to store platform measurements that help ensure that the platform remains trustworthy. Authentication (ensuring that the platform can prove that it is what it claims to be) and attestation (a process helping to prove that a platform is trustworthy and has not been breached) are necessary steps to ensure safer computing in all environments.

Table 19 Available TPM Option

Product ID (PID)	Description
UCSX-TPM2-001	Trusted Platform Module 1.2 for UCS (SPI-based)
UCSX-TPM2-002	Trusted Platform Module 2.0 for UCS servers

### NOTE:

1. The TPM module used in this system conforms to TPM v1.2 and 2.0, as defined by the Trusted Computing Group (TCG). It is also SPI-based.
  - 2. TPM installation is supported after-factory. However, a TPM installs with a one-way screw and cannot be replaced, upgraded, or moved to another server. If a server with a TPM is returned, the replacement server must be ordered with a new TPM. If there is no existing TPM in the server, you can install TPM 2.0. Refer to the following document for Installation location and instructions: [Cisco UCS B200 M5 Server Installation Guide](#).

## STEP 11 CHOOSE OPTIONAL INTERNAL USB 3.0 DRIVE

You may order one optional internal USB 3.0 drive. The USB drive ordering information is listed in [Table 20](#).

Table 20 Available USB Option

Product ID (PID)	Description
UCS-USBFLSHB-16GB	UCS Servers 16GB Flash USB Drive



**NOTE:** A clearance of 0.950 inches (24.1 mm) is required for the USB device to be inserted and removed (see [Figure 4](#)).

The USB drive listed in [Table 20](#) has the correct clearance. If you choose your own USB drive, it must have the required clearance.

Figure 4 USB Clearance

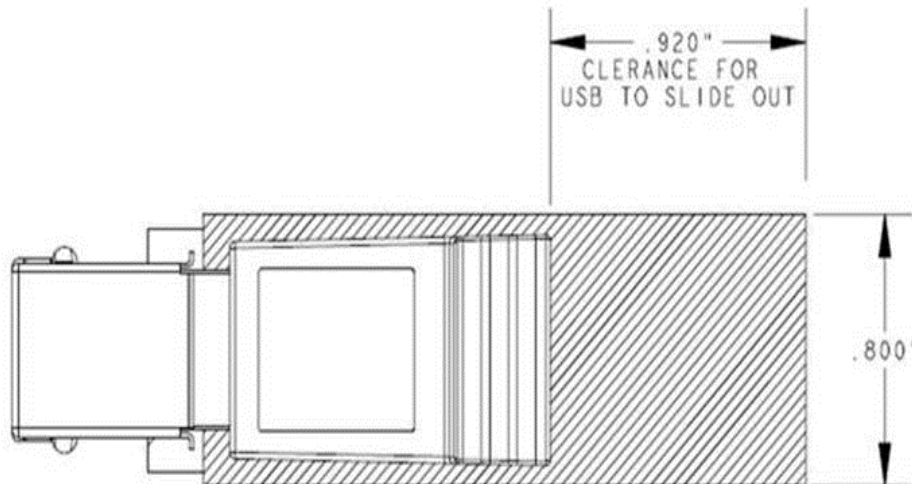

## STEP 12 CHOOSE OPERATING SYSTEM AND VALUE-ADDED SOFTWARE

For more details on supported operating systems and software for this server, see the Hardware and Software Compatibility List (HCL)

Select

- Cisco Software ([Table 21](#))
- OEM Software ([Table 22](#))
- Operating System ([Table 22](#))

Table 21 Cisco Software

Product ID (PID)	PID Description
<b>UCS Director</b>	
CUIC-PHY-SERV-BM-U	Cisco UCS Director Resource Lic - 1 Phy Server node bare metal
CUIC-PHY-SERV-U	Cisco UCS Director Resource Lic - One physical Server node
CUIC-TERM	Acceptance of Cisco UCS Director License Terms
<b>Nexus 1000V for Hyper-V and vSphere</b>	
N1K-VSG-UCS-BUN	Nexus 1000V Adv Edition for vSphere Paper License Qty 1
<b>UCS Multi-Domain Manager</b>	
UCS-MDMGR-1S	UCS Central Per Server License
<p><b>NOTE:</b> IF you must order quantity greater than 1 of UCS-MDMGR-1S, you need to reference the UCS Central Per Server Data Sheet to order the standalone PIDs: UCS-MDMGR-LIC= or UCS-MDMGR-1DMN=</p>	

Table 22 OEM Software

Product ID (PID)	PID Description
<b>VMware vCenter</b>	
VMW-VCS-STD-1A	VMware vCenter 6 Server Standard, 1 yr support required
VMW-VCS-STD-3A	VMware vCenter 6 Server Standard, 3 yr support required
VMW-VCS-STD-5A	VMware vCenter 6 Server Standard, 5 yr support required
VMW-VCS-FND-1A	VMware vCenter 6 Server Foundation (4 Host), 1 yr supp reqd
VMW-VCS-FND-3A	VMware vCenter 6 Server Foundation (4 Host), 3 yr supp reqd
VMW-VCS-FND-5A	VMware vCenter 6 Server Foundation (4 Host), 5 yr supp reqd

Table 23 Operating System

Product ID (PID)	PID Description
<b>Microsoft Windows Server</b>	
MSWS-19-DC16C	Windows Server 2019 Data Center (16 Cores/Unlimited VMs)
MSWS-19-DC16C-NS	Windows Server 2019 DC (16 Cores/Unlim VMs) - No Cisco SVC
MSWS-19-ST16C	Windows Server 2019 Standard (16 Cores/2 VMs)
MSWS-19-ST16C-NS	Windows Server 2019 Standard (16 Cores/2 VMs) - No Cisco SVC
<b>Red Hat</b>	
RHEL-2S2V-1A	Red Hat Enterprise Linux (1-2 CPU,1-2 VN); 1-Yr Support Req
RHEL-2S2V-3A	Red Hat Enterprise Linux (1-2 CPU,1-2 VN); 3-Yr Support Req
RHEL-2S2V-5A	Red Hat Enterprise Linux (1-2 CPU,1-2 VN); 5-Yr Support Req
RHEL-VDC-2SUV-1A	RHEL for Virt Datacenters (1-2 CPU, Unlim VN) 1 Yr Supp Req
RHEL-VDC-2SUV-3A	RHEL for Virt Datacenters (1-2 CPU, Unlim VN) 3 Yr Supp Req
RHEL-VDC-2SUV-5A	RHEL for Virt Datacenters (1-2 CPU, Unlim VN) 5 Yr Supp Req
<b>Red Hat Ent Linux/ High Avail/ Res Strg/ Scal</b>	
RHEL-2S2V-1S	Red Hat Enterprise Linux (1-2 CPU,1-2 VN); Prem 1-Yr SnS
RHEL-2S2V-3S	Red Hat Enterprise Linux (1-2 CPU,1-2 VN); Prem 3-Yr SnS
RHEL-2S-HA-1S	RHEL High Availability (1-2 CPU); Premium 1-yr SnS
RHEL-2S-HA-3S	RHEL High Availability (1-2 CPU); Premium 3-yr SnS
RHEL-2S-RS-1S	RHEL Resilent Storage (1-2 CPU); Premium 1-yr SnS
RHEL-2S-RS-3S	RHEL Resilent Storage (1-2 CPU); Premium 3-yr SnS
RHEL-2S-SFS-1S	RHEL Scalable File System (1-2 CPU); Premium 1-yr SnS
RHEL-2S-SFS-3S	RHEL Scalable File System (1-2 CPU); Premium 3-yr SnS
RHEL-VDC-2SUV-1S	RHEL for Virt Datacenters (1-2 CPU, Unlim VN) 1 Yr SnS Reqd
RHEL-VDC-2SUV-3S	RHEL for Virt Datacenters (1-2 CPU, Unlim VN) 3 Yr SnS Reqd
<b>Red Hat SAP</b>	
RHEL-SAP-2S2V-1S	RHEL for SAP Apps (1-2 CPU, 1-2 VN); Prem 1-Yr SnS
RHEL-SAP-2S2V-3S	RHEL for SAP Apps (1-2 CPU, 1-2 VN); Prem 3-Yr SnS
RHEL-SAPH-2S2V-1S	RHEL for SAP Hana (1-2 CPU, 1-2 VN); Prem 1-Yr SnS
RHEL-SAPH-2S2V-3S	RHEL for SAP Hana (1-2 CPU, 1-2 VN); Prem 3-Yr SnS



Table 23 (continued) Operating System

Product ID (PID)	PID Description
RHEL-SAPHHAS2S-1S	RHEL for SAP Hana,HA,SmartM (1-2 CPU & VN); Std 1Yr SnS Reqd
RHEL-SAPHHAS2S-3S	RHEL for SAP Hana,HA,SmartM (1-2 CPU & VN); Std 3Yr SnS Reqd
RHEL-SAPHHAP2S-1S	RHEL for SAP Hana,HA,SmartM (1-2 CPU &VN); Prem 1Yr SnS Reqd
RHEL-SAPHHAP2S-3S	RHEL for SAP Hana,HA,SmartM (1-2 CPU &VN); Prem 3Yr SnS Reqd
<b>VMware</b>	
VMW-VSP-STD-1A	VMware vSphere 6 Standard (1 CPU), 1-yr, Support Required
VMW-VSP-STD-3A	VMware vSphere 6 Standard (1 CPU), 3-yr, Support Required
VMW-VSP-STD-5A	VMware vSphere 6 Standard (1 CPU), 5-yr, Support Required
VMW-VSP-EPL-3A	VMware vSphere 6 Ent Plus (1 CPU), 3-yr, Support Required
VMW-VSP-EPL-1A	VMware vSphere 6 Ent Plus (1 CPU), 1-yr, Support Required
VMW-VSP-EPL-5A	VMware vSphere 6 Ent Plus (1 CPU), 5-yr, Support Required
<b>SUSE</b>	
SLES-2S2V-1A	SUSE Linux Enterprise Svr (1-2 CPU,1-2 VM); 1-Yr Support Req
SLES-2SUV-1A	SUSE Linux Enterprise Svr (1-2 CPU,Unl VM); 1-Yr Support Req
SLES-2S2V-3A	SUSE Linux Enterprise Svr (1-2 CPU,1-2 VM); 3-Yr Support Req
SLES-2SUV-3A	SUSE Linux Enterprise Svr (1-2 CPU,Unl VM); 3-Yr Support Req
SLES-2S2V-5A	SUSE Linux Enterprise Svr (1-2 CPU,1-2 VM); 5-Yr Support Req
SLES-2SUV-5A	SUSE Linux Enterprise Svr (1-2 CPU,Unl VM); 5-Yr Support Req
SLES-2S2V-1S	SUSE Linux Enterprise Svr (1-2 CPU,1-2 VM); Prio 1-Yr SnS
SLES-2SUV-1S	SUSE Linux Enterprise Svr (1-2 CPU,Unl VM); Prio 1-Yr SnS
SLES-2S2V-3S	SUSE Linux Enterprise Svr (1-2 CPU,1-2 VM); Prio 3-Yr SnS
SLES-2SUV-3S	SUSE Linux Enterprise Svr (1-2 CPU,Unl VM); Prio 3-Yr SnS
SLES-2S2V-5S	SUSE Linux Enterprise Svr (1-2 CPU,1-2 VM); Prio 5-Yr SnS
SLES-2SUV-5S	SUSE Linux Enterprise Svr (1-2 CPU,Unl VM); Prio 5-Yr SnS
SLES-2S-HA-1S	SUSE Linux High Availability Ext (1-2 CPU); 1yr SnS
SLES-2S-HA-3S	SUSE Linux High Availability Ext (1-2 CPU); 3yr SnS
SLES-2S-HA-5S	SUSE Linux High Availability Ext (1-2 CPU); 5yr SnS
SLES-2S-GC-1S	SUSE Linux GEO Clustering for HA (1-2 CPU); 1yr Sns

Table 23 (continued) Operating System

Product ID (PID)	PID Description
SLES-2S-GC-3S	SUSE Linux GEO Clustering for HA (1-2 CPU); 3yr SnS
SLES-2S-GC-5S	SUSE Linux GEO Clustering for HA (1-2 CPU); 5yr SnS
SLES-2S-LP-1S	SUSE Linux Live Patching Add-on (1-2 CPU); 1yr SnS Required
SLES-2S-LP-3S	SUSE Linux Live Patching Add-on (1-2 CPU); 3yr SnS Required
SLES-2S-LP-1A	SUSE Linux Live Patching Add-on (1-2 CPU); 1yr Support Req
SLES-2S-LP-3A	SUSE Linux Live Patching Add-on (1-2 CPU); 3yr Support Req
<b>SLES and SAP</b>	
SLES-SAP-2S2V-1A	SLES for SAP Apps (1-2 CPU, 1-2 VM); 1-Yr Support Reqd
SLES-SAP-2SUV-1A	SLES for SAP Apps (1-2 CPU, Unl VM); 1-Yr Support Reqd
SLES-SAP-2S2V-3A	SLES for SAP Apps (1-2 CPU, 1-2 VM); 3-Yr Support Reqd
SLES-SAP-2SUV-3A	SLES for SAP Apps (1-2 CPU, Unl VM); 3-Yr Support Reqd
SLES-SAP-2S2V-5A	SLES for SAP Apps (1-2 CPU, 1-2 VM); 5-Yr Support Reqd
SLES-SAP-2SUV-5A	SLES for SAP Apps (1-2 CPU, Unl VM); 5-Yr Support Reqd
SLES-SAP-2S2V-1S	SLES for SAP Apps (1-2 CPU, 1-2 VM); Priority 1-Yr SnS
SLES-SAP-2SUV-1S	SLES for SAP Apps (1-2 CPU, Unl VM); Priority 1-Yr SnS
SLES-SAP-2S2V-3S	SLES for SAP Apps (1-2 CPU, 1-2 VM); Priority 3-Yr SnS
SLES-SAP-2SUV-3S	SLES for SAP Apps (1-2 CPU, Unl VM); Priority 3-Yr SnS
SLES-SAP-2S2V-5S	SLES for SAP Apps (1-2 CPU, 1-2 VM); Priority 5-Yr SnS
SLES-SAP-2SUV-5S	SLES for SAP Apps (1-2 CPU, Unl VM); Priority 5-Yr SnS

## STEP 13 CHOOSE OPTIONAL OPERATING SYSTEM MEDIA KIT

Select the optional operating system media listed in [Table 24](#)

Table 24 OS Media

Product ID (PID)	PID Description
MSWS-19-ST16C-RM	Windows Server 2019 Stan (16 Cores/2 VMs) Rec Media DVD Only
MSWS-19-DC16C-RM	Windows Server 2019 DC (16Cores/Unlim VM) Rec Media DVD Only

## STEP 14 CHOOSE SERVICE and SUPPORT LEVEL

A variety of service options are available, as described in this section.

### Unified Computing Warranty, No Contract

If you have noncritical implementations and choose to have no service contract, the following coverage is supplied:

- Three-year parts coverage.
- Next business day (NBD) parts replacement eight hours a day, five days a week.
- 90-day software warranty on media.
- Downloads of BIOS, drivers, and firmware updates.
- UCSM updates for systems with Unified Computing System Manager. These updates include minor enhancements and bug fixes that are designed to maintain the compliance of UCSM with published specifications, release notes, and industry standards.

## Unified Computing Support Service

For support of the entire Unified Computing System, Cisco offers the Cisco Smart Net Total Care for UCS Service. This service provides expert software and hardware support to help sustain performance and high availability of the unified computing environment. Access to Cisco Technical Assistance Center (TAC) is provided around the clock, from anywhere in the world

For systems that include Unified Computing System Manager, the support service includes downloads of UCSM upgrades. The Cisco Smart Net Total Care for UCS Service includes flexible hardware replacement options, including replacement in as little as two hours. There is also access to Cisco's extensive online technical resources to help maintain optimal efficiency and uptime of the unified computing environment. For more information please refer to the following url: <http://www.cisco.com/c/en/us/services/technical/smart-net-total-care.html?stickynav=1> You can choose a desired service listed in *Table 25*.

Table 25 Unified Computing Support Service

Service SKU	Service Level GSP	On Site?	Description
CON-PREM-SBB200M5	C2P	Yes	SNTC 24X7X2OS
CON-UCSD8-SBB200M5	UCSD8	Yes	UC SUPP DR 24X7X2OS*
CON-C2PL-SBB200M5	C2PL	Yes	LL 24X7X2OS**
CON-OSP-SBB200M5	C4P	Yes	SNTC 24X7X4OS
CON-UCSD7-SBB200M5	UCSD7	Yes	UCS DR 24X7X4OS*
CON-C4PL-SBB200M5	C4PL	Yes	LL 24X7X4OS**
CON-USD7L-SBB200M5	USD7L	Yes	LLUCS HW DR 24X7X4OS***
CON-OSE-SBB200M5	C4S	Yes	SNTC 8X5X4OS

Table 25 Unified Computing Support Service (*continued*)

Service SKU	Service Level GSP	On Site?	Description
CON-UCSD6-SBB200M5	UCSD6	Yes	UC SUPP DR 8X5X4OS*
CON-SNCO-SBB200M5	SNCO	Yes	SNTC 8x7xNCDOS****
CON-OS-SBB200M5	CS	Yes	SNTC 8X5XNBDOS
CON-UCSD5-SBB200M5	UCSD5	Yes	UCS DR 8X5XNBDOS*
CON-S2P-SBB200M5	S2P	No	SNTC 24X7X2
CON-S2PL-SBB200M5	S2PL	No	LL 24X7X2**
CON-SNTP-SBB200M5	SNTP	No	SNTC 24X7X4
CON-SNTPL-SBB200M5	SNTPL	No	LL 24X7X4**
CON-SNTE-SBB200M5	SNTE	No	SNTC 8X5X4
CON-SNC-SBB200M5	SNC	No	SNTC 8x7xNCD****
CON-SNT-SBB200M5	SNT	No	SNTC 8X5XNBD
CON-SW-SBB200M5	SW	No	SNTC NO RMA

Note: For PID UCSB-B200-M5-U, select Service SKU with BB200M5U suffix (Example: CON-PREM- BB200M5U)

For PID UCSB-B200-M5-CH, select Service SKU with B200M5CH suffix (Example: CON-PREM- B200M5CH)

\*Includes Drive Retention (see [UCS Drive Retention Service on page 48](#))

\*\*Includes Local Language Support (see [Local Language Technical Support for UCS on page 49](#)) - Only available in China and Japan

\*\*\*Includes Local Language Support and Drive Retention - Only available in China and Japan

\*\*\*\*Available in China Only

## Smart Net Total Care for Cisco UCS Onsite Troubleshooting Service

For faster parts replacement than is provided with the standard Cisco Unified Computing System warranty, Cisco offers the Cisco Smart Net Total Care for UCS Hardware Only Service. You can choose from two levels of advanced onsite parts replacement coverage in as little as four hours. Smart Net Total Care for UCS Hardware Only Service provides remote access any time to Cisco support professionals who can determine if a return materials authorization (RMA) is required. You can choose a desired service listed in [Table 26](#).

Table 26 SNTC for Cisco UCS Onsite Troubleshooting Service (PID UCSB-B200-M5)

Service SKU	Service Level GSP	On Site?	Description
CON-UCW7-SBB200M5	UCW7	Yes	UCS HW 24X7X4OS
CON-UCWD7-SBB200M5	UCWD7	Yes	UCS HW+DR 24X7X4OS*

Table 26 SNTC for Cisco UCS Onsite Troubleshooting Service (PID UCSB-B200-M5) (continued)

Service SKU	Service Level GSP	On Site?	Description
CON-UCW7L-SBB200M5	UCW7L	Yes	LL UCS 24X7X4OS**
CON-UWD7L-SBB200M5	UWD7L	Yes	LL UCS DR 24X7X4OS***
CON-UCW5-SBB200M5	UCW5	Yes	UCS HW 8X5XNBDOS
CON-UCWD5-SBB200M5	UCWD5	Yes	UCS HW+DR 8X5XNBDOS*

Note: For PID UCSB-B200-M5-U, select Service SKU with BB200M5U suffix (Example: CON-PREM- BB200M5U)  
 For PID UCSB-B200-M5-CH, select Service SKU with B200M5CH suffix (Example: CON-PREM- B200M5CH)

\*Includes Drive Retention (see [UCS Drive Retention Service on page 48](#))

\*\*Includes Local Language Support (see [Local Language Technical Support for UCS on page 49](#)) - Only available in China and Japan

\*\*\*Includes Local Language Support and Drive Retention - Only available in China and Japan

## Partner Support Service for UCS

Cisco Partner Support Service (PSS) is a Cisco Collaborative Services service offering that is designed for partners to deliver their own branded support and managed services to enterprise customers. Cisco PSS provides partners with access to Cisco's support infrastructure and assets to help them:

- Expand their service portfolios to support the most complex network environments
- Lower delivery costs
- Deliver services that increase customer loyalty

PSS options enable eligible Cisco partners to develop and consistently deliver high-value technical support that capitalizes on Cisco intellectual assets. This helps partners to realize higher margins and expand their practice.

PSS is available to all Cisco PSS partners.

The two Partner Unified Computing Support Options include:

- Partner Support Service for UCS
- Partner Support Service for UCS Hardware Only

PSS for UCS provides hardware and software support, including triage support for third party software, backed by Cisco technical resources and level three support. You can choose a desired service listed in [Table 27](#).

Table 27 PSS for UCS (PID UCSB-B200-M5)

Service SKU	Service Level GSP	On Site?	Description
CON-PSJ8-SBB200M5	PSJ8	Yes	UCS PSS 24X7X2 OS
CON-PSJ7-SBB200M5	PSJ7	Yes	UCS PSS 24X7X4 OS

Table 27 PSS for UCS (PID UCSB-B200-M5) (continued)

Service SKU	Service Level GSP	On Site?	Description
CON-PSJD7-SBB200M5	PSJD7	Yes	UCS PSS 24X7X4 DR*
CON-PSJ6-SBB200M5	PSJ6	Yes	UCS PSS 8X5X4 OS
CON-PSJD6-SBB200M5	PSJD6	Yes	UCS PSS 8X5X4 DR*
CON-PSJ4-SBB200M5	PSJ4	No	UCS SUPP PSS 24X7X2
CON-PSJ3-SBB200M5	PSJ3	No	UCS SUPP PSS 24X7X4
CON-PSJ2-SBB200M5	PSJ2	No	UCS SUPP PSS 8X5X4
CON-PSJ1-SBB200M5	PSJ1	No	UCS SUPP PSS 8X5XNBD

Note: For PID UCSB-B200-M5-U, select Service SKU with BB200M5U suffix (Example: CON-PREM- BB200M5U)  
For PID UCSB-B200-M5-CH, select Service SKU with B200M5CH suffix (Example: CON-PREM- B200M5CH)

\*Includes Drive Retention (see [UCS Drive Retention Service on page 48](#))

## PSS for UCS Hardware Only

PSS for UCS Hardware Only provides customers with replacement parts in as little as two hours and provides remote access any time to Partner Support professionals who can determine if a return materials authorization (RMA) is required. You can choose a desired service listed in [Table 28](#)

Table 28 PSS for UCS Hardware Only (PID UCSB-B200-M5)

Service SKU	Service Level GSP	On Site?	Description
CON-PSW7-SBB200M5	PSW7	Yes	UCS W PSS 24X7X4 OS
CON-PSWD7-SBB200M5	PSWD7	Yes	UCS W PSS 24X7X4 DR*
CON-PSW6-SBB200M5	PSW6	Yes	UCS W PSS 8X5X4 OS
CON-PSWD6-SBB200M5	PSWD6	Yes	UCS W PSS 8X5X4 DR*
CON-PSW4-SBB200M5	PSW4	No	UCS W PL PSS 24X7X2
CON-PSW3-SBB200M5	PSW3	No	UCS W PL PSS 24X7X4
CON-PSW2-SBB200M5	PSW2	No	UCS W PL PSS 8X5X4

Note: For PID UCSB-B200-M5-U, select Service SKU with BB200M5U suffix (Example: CON-PREM- BB200M5U)  
For PID UCSB-B200-M5-CH, select Service SKU with B200M5CH suffix (Example: CON-PREM- B200M5CH)

\*Includes Drive Retention (see [UCS Drive Retention Service on page 48](#))

## Unified Computing Combined Support Service

Combined Services makes it easier to purchase and manage required services under one contract. SNTC services for UCS help increase the availability of your vital data center infrastructure and realize the most value from your unified computing investment. The more benefits you realize from the Cisco Unified Computing System (Cisco UCS), the more important the technology becomes to your business. These services allow you to:

- Optimize the uptime, performance, and efficiency of your UCS
- Protect your vital business applications by rapidly identifying and addressing issues
- Strengthen in-house expertise through knowledge transfer and mentoring
- Improve operational efficiency by allowing UCS experts to augment your internal staff resources
- Enhance business agility by diagnosing potential issues before they affect your operations You can choose a desired service listed in [Table 29](#).

**Table 29 Combined Support Service for UCS (PID UCSB-B200-M5)**

Service SKU	Service Level GSP	On Site?	Description
CON-NCF2P-SBB200M5	NCF2P	Yes	CMB SVC 24X7X2OS
CON-NCF4P-SBB200M5	NCF4P	Yes	CMB SVC 24X7X4OS
CON-NCF4S-SBB200M5	NCF4S	Yes	CMB SVC 8X5X4OS
CON-NCFCS-SBB200M5	NCFCS	Yes	CMB SVC 8X5XNBDOS
CON-NCF2-SBB200M5	NCF2	No	CMB SVC 24X7X2
CON-NCFP-SBB200M5	NCFP	No	CMB SVC 24X7X4
CON-NCFE-SBB200M5	NCFE	No	CMB SVC 8X5X4
CON-NCFT-SBB200M5	NCFT	No	CMB SVC 8X5XNBD
CON-NCFW-SBB200M5	NCFW	No	CMB SVC SW

Note: For PID UCSB-B200-M5-U, select Service SKU with BB200M5U suffix (Example: CON-PREM- BB200M5U)  
For PID UCSB-B200-M5-CH, select Service SKU with B200M5CH suffix (Example: CON-PREM- B200M5CH)

## UCS Drive Retention Service

With the Cisco Unified Computing Drive Retention Service, you can obtain a new disk drive in exchange for a faulty drive without returning the faulty drive.

Sophisticated data recovery techniques have made classified, proprietary, and confidential information vulnerable, even on malfunctioning disk drives. The Drive Retention service enables you to retain your drives and ensures that the sensitive data on those drives is not compromised, which reduces the risk of any potential liabilities. This service also enables you to comply with regulatory, local, and federal requirements.



If your company has a need to control confidential, classified, sensitive, or proprietary data, you might want to consider one of the Drive Retention Services listed in the above tables (where available)



**NOTE:** Cisco does not offer a certified drive destruction service as part of this service.

---

## Local Language Technical Support for UCS

Where available, and subject to an additional fee, local language support for calls on all assigned severity levels may be available for specific product(s) - see tables above.

For a complete listing of available services for Cisco Unified Computing System, see the following URL:  
[http://www.cisco.com/en/US/products/ps10312/serv\\_group\\_home.html](http://www.cisco.com/en/US/products/ps10312/serv_group_home.html)

# SUPPLEMENTAL MATERIAL

## System Board

A top view of the UCS B200 M5 system board is shown in *Figure 5*.

Figure 5 UCS B200 M5 System Board

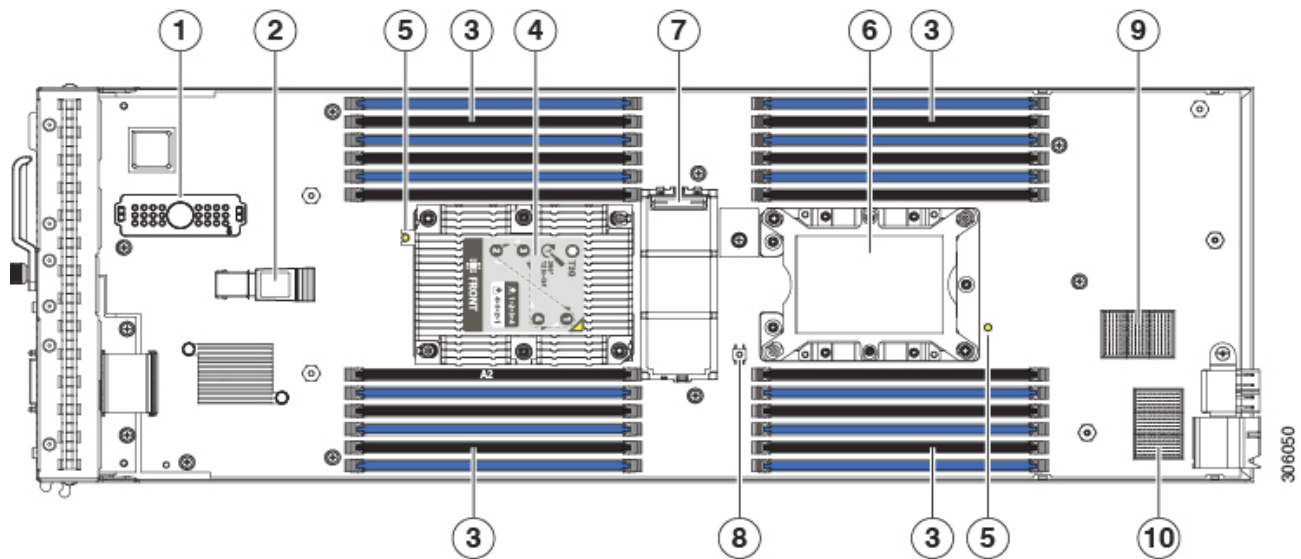

1	Front mezzanine connector	2	USB connector (shown populated) An internal USB 3.0 port is supported. A 16 GB USB drive (UCS-USBFLSHB-16GB) is available from Cisco. A clearance of 0.950 inches (24.1 mm) is required for the USB device to be inserted and removed.
3	DIMM slots	4	CPU 1 socket (shown populated)
5	CPU heat sink install guide pins	6	CPU 2 socket (shown unpopulated)
7	Mini storage connector	8	Diagnostic button
9	mLOM connector	10	Rear mezzanine connector



**Note:** When the front mezzanine storage module is installed, the USB connector is underneath it. Use the small cutout opening in the storage module to visually determine the location of the USB connector when you need to insert a USB drive. When the NVIDIA GPU is installed in the front mezzanine slot, you cannot see the USB connector.

## Memory Configuration and Mirroring

When the Memory Mirroring PID (N01-MMIRROR) is selected in [Table 4 Available DDR4 DIMMs and PMEMs, page 17](#), the DIMMs will be placed as shown in [Table 31 on page 53](#) by the factory

Each CPU has six DIMM channels:

- CPU1 has channels A, B, C, D, E, and F
- CPU2 has channels G, H, J, K, L, and M

Each DIMM channel has two slots: slot 1 and slot 2. The blue-colored DIMM slots are for slot 1 and the black slots for slot 2.

As an example, DIMM slots A1, B1, C1, D1, E1, and F1 belong to slot 1, while A2, B2, C2, D2, E2, and F2 belong to slot 2.

[Figure 6](#) shows how slots and channels are physically laid out on the motherboard. The DIMM slots on the right half of the motherboard (channels A, B, C, D, E, and F) are associated with CPU 1, while the DIMM slots on the left half of the motherboard (channels G, H, J, K, L, and M) are associated with CPU 2. The slot 1 (blue) DIMM slots are always located farther away from a CPU than the corresponding slot 2 (black) slots.

Figure 6 Physical Layout of CPU DIMM Channels and Slots



For all allowable DIMM populations, please refer to the “Memory Population Guidelines” section of the B200 M5 Installation Guide, at the following link:

[https://www.cisco.com/c/en/us/td/docs/unified\\_computing/ucs/hw/blade-servers/B200M5.pdf](https://www.cisco.com/c/en/us/td/docs/unified_computing/ucs/hw/blade-servers/B200M5.pdf)

For more details, see the Cisco UCS C220/C240/B200 M5 memory Guide at the following link:

<https://www.cisco.com/c/dam/en/us/products/collateral/servers-unified-computing/ucs-c-series-rack-servers/memory-guide-c220-c240-b200-m5.pdf>

When considering the memory configuration of your server, consider the following items:

- Each channel has two DIMM slots (for example, channel A = slots A1 and A2).
  - A channel can operate with one or two DIMMs installed.
- When both CPUs are installed, populate the DIMM slots of each CPU identically.
- Any DIMM installed in a DIMM socket for which the CPU is absent is not recognized.

- Observe the DIMM mixing rules shown in [Table 30](#).

Table 30 DIMM Rules for B200 M5 Servers

DIMM Parameter	DIMMs in the Same Channel	DIMM in the Same Slot <sup>1</sup>
DIMM Capacity RDIMM = 16, 32, or 64 GB LRDIMM = 32, 64, or 128 GB TSV-RDIMM = 64 or 128 GB <sub>L</sub>	DIMMs in the same channel (for example, A1 and A2) can have different capacities.	For best performance, DIMMs in the same slot (for example, A1, B1, C1, D1, E1, F1) should have the same capacity.
	Do not mix TSV-RDIMMS with LRDIMMS nor RDIMMS	Do not mix TSV-RDIMMS with LRDIMMS nor RDIMMS
DIMM Speed 2933- or 2666-MHz	DIMMs will run at the lowest speed of the CPU installed	DIMMs will run at the lowest speed of the CPU installed
DIMM Type TSV-RDIMMS, RDIMMS, or LRDIMMS	Do not mix DIMM types in a channel	Do not mix DIMM types in a slot

**Notes:**

1. Although different DIMM capacities can exist in the same slot, this will result in less than optimal performance. For optimal performance, all DIMMs in the same slot should be identical.

- The DIMM/PMEM guidelines are as follows:
  - All DDR4 DIMMs populated in the DIMM slots must be the same size.
  - If you select any PMEMs, you must also select two CPUs and 12 DIMMs. You can have 4, 8, or 12 PMEMs, but you must select 12 DIMMs any time you select PMEMs.
  - PMEMs populated in the DIMM slots must all be the same size. PMEM size mixing is not allowed (for example, you cannot mix 512 GB and 128 GB PMEMs within the same server).
  - You cannot select more than 1024 GB of PMEM memory per CPU for non “L” series CPUs.
  - The PMEMs run at 2666 MHz. If you have 2933-MHz RDIMMS or LRDIMMS in the server and you add PMEMs, the main memory speed clocks down to 2666 MHz to match the speed of the PMEMs.
  - The recommended DIMM:PMEM capacity ratio is from 1:4 through 1:16.
  - Both PMEM operational modes (App Direct and Memory Mode) are compatible with the B200 M5.
  - Using non-Cisco supported hardware configurations may result in slower performance or a non-supported warning during bootup.

## Memory Mirroring

When Memory Mirroring PID (N01-MMIRROR) is selected in *STEP 3 CHOOSE MEMORY, page 16*, the DIMMS will be placed by the factory as shown in the *Table 31*.

- Select 4, 6, 8, or 12 identical DIMMS per CPU.
- If only 1 CPU is selected, please refer only to the CPU 1 DIMM placement columns in the *Table 31*.

Table 31 Memory Mirroring

DIMM Rank	CPU 1 DIMM Placement in Channels (for identical ranked DIMMS)	CPU 2 DIMM Placement in Channels (for identical ranked DIMMS)
4	(A1, B1); (D1, E1)	(G1, H1); (K1, L1)
6	(A1, B1); (C1, D1); (E1, F1)	(G1, H1); (J1, K1); (L1, M1)
8	(A1, B1); (D1, E1); (A2, B2); (D2, E2)	(G1, H1); (K1, L1); (G2, H2); (K2, L2)
12	(A1, B1); (C1, D1); (E1, F1); (A2, B2); (C2, D2); (E2, F2)	(G1, H1); (J1, K1); (L1, M1); (G2, H2); (J2, K2); (L2, M2)

## Memory Support for CPU Classes and CPU Modes

### For 2<sup>nd</sup> Generation Intel® Xeon® Scalable Processors:

- DIMMs and PMEMs are supported
- CPU PIDs ending in “M” support up to a limit of 2048 GB per CPU
- CPU PIDs ending in “L” support up to a limit of 4608 GB per CPU
- All other CPU PIDs support up to a limit of 1024 GB per CPU
- For the App Direct Mode, both PMEM and DIMM capacities count towards the CPU capacity limit
- For the Memory Mode and Mixed Mode only the PMEM capacity counts towards the CPU capacity limit

### For Configurations Using Only DIMMs

- CPU PIDs ending in “M” support DIMM capacities up to 1536 GB per CPU (using 12 x 128 GB DIMMs) and DIMM capacities up to 2048 GB per CPU (using 8 x 256 GB DIMMs).
- CPU PIDs ending in “L” support DIMM capacities up to 1536 GB per CPU (using 12 x 128 GB DIMMs) and DIMM capacities up to 3072 GB per CPU (using 12 x 256 GB DIMMs). The 4608 GB limit cannot be reached with these capacity DIMMs.
- CPU PIDs not ending in “L” or “M” support DIMM capacities up to 1024 GB per CPU (using 8 x 128 GB DIMMs or 4 x 256 GB DIMMs).

### For Configurations Using DIMMs and PMEMs in [App Direct Mode](#)

- CPU PIDs ending in “M” support capacities up to 1792 GB per CPU (using 6 x 128 GB DIMMs and 2 x 512 GB PMEMs or 4 x 256 GB PMEMs) or up to 2048 GB per CPU (using 6 x 256 GB DIMMs and 2 x 256 GB PMEMs or 6 x 256 GB DIMMs and 4 x 128 GB PMEMs)
- CPU PIDs ending in “L” support capacities up to 3840 GB per CPU (using 6 x 128 GB DIMMs and 6 x 512 GB PMEMs) or up to 4608 GB per CPU (using 6 x 256 GB DIMMs and 6 x 512 GB PMEMs)
- CPU PIDs not ending in “L” or “M” support capacities up to 1024 GB per CPU (using 6 x 128 GB DIMMs and 2 x 128 GB PMEMs).

### For Configurations Using DIMMs and PMEMs in [Memory or Mixed Mode](#)



**NOTE:** For Memory and Mixed Modes, DIMMs are used as cache and do not factor into CPU capacity.

---

- CPU PIDs ending in “M” support capacities up to 2048 GB per CPU using:
  - 6 x 128 GB DIMMs as cache and 4 x 512 GB PMEMs as memory, or
  - 6x 256 GB DIMMs as cache and 4 x 512 GB PMEMs as memory
- CPU PIDs ending in “L” support capacities up to 3072 GB using:
  - 6 x 128 GB DIMMs as cache and 6 x 512 GB PMEMs as memory, or

- 6 x 256 GB DIMMs as cache and 6 x 512 GB PMEMs as memory

The allowable 4608 limit for PMEM capacity is not reached in this case.

- CPU PIDs not ending in "L" or "M" support capacities up to 1024 GB per CPU using:
  - 6 x 128 GB DIMMs as cache and 2 x 512 GB PMEMs as memory, or
  - 6 x 256 GB DIMMs as cache and 2 x 512 GB PMEMs as memory

### For Intel® Xeon® Scalable Processors:

- DIMMs are supported; PMEMs are not supported
- CPU PIDs ending in "M" support DIMM capacities up to 1536 GB per CPU (using 12 x 128 GB DIMMs).
- All other CPU PIDs support DIMM capacities up to 768 GB per CPU (using 6 x 128 GB DIMMs or 12 x 64 GB DIMMs)

## SPARE PARTS

This section lists the upgrade and service-related parts for the UCS B480 M5 server. Some of these parts are configured with every server or with every UCS 5108 blade server chassis.

Table 32 Spare Parts

Product ID (PID)	PID Description
<b>Local KVM I/O Cable</b>	
N20-BKVM=	KVM local IO cable for UCS servers console port
<b>CPU Accessories</b>	
UCSB-HS-M5-F=	CPU Heat Sink for UCS B-Series M5 CPU socket (Front)
UCSB-HS-M5-R=	CPU Heat Sink for UCS B-Series M5 CPU socket (Rear)
UCS-CPU-TIM=	Single CPU thermal interface material syringe for M5 server HS seal
UCSX-HSCK=	UCS Processor Heat Sink Cleaning Kit (when replacing a CPU)2
UCS-CPUAT=	CPU Assembly Tool for M5 Servers
UCS-M5-CPU-CAR=	UCS M5 CPU Carrier
<b>Memory</b>	
UCS-DIMM-BLK	UCS DIMM Blanks
UCS-MR-128G8RS-H=	128 GB DDR4-2666-MHz TSV-RDIMM/8R/x4
UCS-MR-X64G4RS-H=	64 GB DDR4-2666-MHz TSV-RDIMM/4R/x4
UCS-ML-X64G4RS-H=	64 GB DDR4-2666-MHz LRDIMM/4R/x4
UCS-MR-X32G2RS-H=	32 GB DDR4-2666-MHz RDIMM/2R/x4
UCS-ML-X32G2RS-H=	32 GB DDR4-2666-MHz LDIMM/2R/x4
UCS-MR-X16G1RS-H=	16 GB DDR4-2666-MHz RDIMM/1R/x4
UCS-ML-X64G4RT-H=	64 GB DDR4-2933-MHz LRDIMM/4Rx4 (8Gb) 1.2v
UCS-MR-X64G2RT-H=	64 GB DDR4-2933-MHz RDIMM/2Rx4 (16Gb) 1.2v
<b>Storage Controller</b>	
UCSB-MRAID-SC=	Supercap for FlexStorage 12G SAS RAID controller w/1GB FBWC
UCSB-MRAID12G=	Cisco FlexStorage 12G SAS RAID controller with drive bays
UCSB-MRAID12G-HE=	Cisco FlexStorage 12G SAS RAID controller with 2 GB flash-backed write cache and drive bays
UCSB-LSTOR-PT=	Cisco FlexStorage Passthrough module w/drive bays
UCSB-LSTOR-BK=	Cisco FlexStorage blanking panel w/o controller, w/o drive bays



Table 32 Spare Parts

**Drives****HDDs****HDDs (15K RPM)**

UCS-HD300G15K12G= 300 GB 12G SAS 15K RPM SFF HDD

UCS-HD600G15K12G= 600 GB 12G SAS 15K RPM SFF HDD

UCS-HD900G15K12G= 900 GB 12G SAS 15K RPM SFF HDD

**HDDs (10K RPM)**

UCS-HD300G10K12G= 300 GB 12G SAS 10K RPM SFF HDD

UCS-HD600G10K12G= 600 GB 12G SAS 10K RPM SFF HDD

UCS-HD12TB10K12G= 1.2 TB 12G SAS 10K RPM SFF HDD

UCS-HD18TB10KS4K= 1.8 TB 12G SAS 10K RPM SFF HDD (4K)

UCS-HD24TB10KS4K= 2.4 TB 12G SAS 10K RPM SFF HDD (4K)

**Enterprise Performance SSDs (High endurance, supports up to 10X or 3X DWPD (drive writes per day))****SAS SSDs**

UCS-SD800GSAS3-EP= 800GB 2.5 inch Enterprise performance 12G SAS SSD(3X endurance) (Toshiba PX05)

UCS-SD16TSASS3-EP= 1.6TB 2.5 inch Enterprise performance 12G SAS SSD(3X endurance) (Toshiba PX05)

UCS-SD400GH3-EP= 400GB 2.5 inch Enterprise performance 12G SAS SSD (3X DWPD)

UCS-SD800GH3-EP= 800GB 2.5 inch Enterprise performance 12G SAS SSD (3X DWPD)

UCS-SD16TH3-EP= 1.6TB 2.5 inch Enterprise performance 12G SAS SSD (3X DWPD)

UCS-SD32TH3-EP= 3.2TB 2.5in Enterprise performance 12G SAS SSD (3X DWPD)

**SATA SSDs**

UCS-SD480GIS3-EP= 480GB 2.5in Enterprise performance 6G SATA SSD(3X endurance) (Intel S4600)

UCS-SD960GIS3-EP= 960GB 2.5in Enterprise performance 6G SATA SSD(3X endurance) (Intel S4600)

UCS-SD19TIS3-EP= 1.9TB 2.5in Enterprise performance 6G SATA SSD(3X endurance) (Intel S4600)

UCS-SD16TB12S3-EP= 1.6TB 2.5 inch Ent. Performance 6GSATA SSD(3X endurance)

UCS-SD800G12S3-EP= 800GB 2.5 inch Enterprise performance 6G SATA SSD(3 FWPDP)

UCS-SD200G12S3-EP= 200GB 2.5 inch Enterprise performance 6G SATA SSD(3 FWPDP)

UCS-SD480GMB3X-EP= 480GB 2.5in Enterprise performance 6GSATA SSD(3X endurance)

UCS-SD960GMB3X-EP= 960GB 2.5in Enterprise performance 6GSATA SSD(3X endurance)

UCS-SD19TMB3X-EP= 1.9TB 2.5in Enterprise performance 6GSATA SSD(3X endurance)

Table 32 Spare Parts

**Enterprise Value (Low endurance, supports up to 1X DWPD (drive writes per day))**

UCS-SD480GSAS-EV=	480 GB 2.5 inch Enterprise Value 12G SAS SSD (Toshiba PX05)
UCS-SD960GSAS-EV=	960 GB 2.5 inch Enterprise Value 12G SAS SSD (Toshiba PX05)
UCS-SD38TSAS-EV=	3.8 TB 2.5 inch Enterprise Value 12G SAS SSD (Toshiba PX05)
UCS-SD19TSAS-EV=	1.9 TB 2.5 inch Enterprise Value 12G SAS SSD
UCS-SD960GBKS4-EV=	960 GB 2.5 inch Enterprise Value 6G SATA SSD (Samsung PM863A/PM883)
UCS-SD38TBKS4-EV=	3.8 TB 2.5 inch Enterprise Value 6G SATA SSD (Samsung PM863A/PM883)
UCS-SD120GBMS4-EV=	120 GB 2.5 inch Enterprise Value 6G SATA SSD (Micron 5100/5200)
UCS-SD240GBMS4-EV=	240 GB 2.5 inch Enterprise Value 6G SATA SSD (Micron 5100/5200)
UCS-SD480GBMS4-EV=	480 GB 2.5 inch Enterprise Value 6G SATA SSD (Micron 5100/5200)
UCS-SD76TBMS4-EV=	7.6 TB 2.5 inch Enterprise Value 6G SATA SSD (Micron 5100/5200)
UCS-SD480GBIS6-EV=	480 GB 2.5 inch Enterprise Value 6G SATA SSD (Intel S4500/S4150)
UCS-SD960GBIS6-EV=	960 GB 2.5 inch Enterprise Value 6G SATA SSD (Intel S4500/S4150)
UCS-SD38TBIS6-EV=	3.8 TB 2.5 inch Enterprise Value 6G SATA SSD (Intel S4500/S4150)

**Self-Encrypted Drives (SED)**

UCS-SD960GBHBNK9=	960GB Enterprise value SAS SSD (1X FWPD, SED)
UCS-HD600G15K9=	600GB 12G SAS 15K RPM SFF HDD (SED)
UCS-HD12G10K9=	1.2 TB 12G SAS 10K RPM SFF HDD (SED)
UCS-HD18G10K9=	1.8TB 12G SAS 10K RPM SFF HDD (4K format, SED)
UCS-HD24T10BNK9=	2.4 TB 12G SAS 10K RPM SFF HDD (4K) SED

**NVMe<sup>1, 2, 3</sup>**

UCSB-NVMEHW-I8000=	Cisco 2.5" U.2 8TB Intel P4510 NVMe High Perf. Value Endurance
UCSB-NVMEXPB-I375=	Cisco 2.5in U.2 375GB Intel P4800 NVMe Med. Perf
UCSB-NVMEXP-I750=	750 GB 2.5in Intel Optane NVMe Extreme Perf
UCSB-NVME2H-I2TBV=	Cisco 2.5" U.2 2.0TB Intel P4510 NVMe High Perf. Value Endurance
UCSB-NVME2H-I1000=	Cisco 2.5" U.2 1,0 TB Intel P4510 NVMe High Perf. Value Endu
UCSB-NVME2H-I1600=	Cisco 2.5" U.2 1.6TB Intel P4610 NVMe High Perf. High Endu
UCSB-NVME2H-I3200=	Cisco 2.5" U.2 3.2TB Intel P4610 NVMe High Perf. High Endurance
UCSB-NVME2H-I4000=	Cisco 2.5" U.2 4.0TB Intel P4510 NVMe High Perf. Value Endu

**Supported Mezzanine cards**

Table 32 Spare Parts

UCSB-MLOM-40G-04=	UCS VIC 1440 modular LOM for blade servers mLOM
UCSB-MLOM-40G-03=	UCS VIC 1340 modular LOM for blade servers mLOM
UCSB-VIC-M84-4P=	Cisco UCS VIC 1480 mezzanine adapter Rear Mezzanine
UCSB-VIC-M83-8P=	Cisco UCS VIC 1380 mezzanine adapter
<b>Port Expander Card for VIC option</b>	
UCSB-MLOM-PT-01=	Cisco UCS Port Expander Card for VIC.
<b>GPUs</b>	
UCSB-GPU-P6-F=	NVIDIA GRID P6 Front Mezzanine
UCSB-GPU-P6-R=	NVIDIA GRID P6 Rear Mezzanine
<b>Cisco Storage Accelerators</b>	
UCSB-F-H-5607=	UCS Blade PCIe/NVMe Storage Mezz 560 GB High Endurance
UCSB-F-H-32003=	UCS Blade PCIe/NVMe Storage Mezz 3200 GB Medium Endurance
<b>Trusted Platform Module</b>	
UCSX-TPM2-001	Trusted Platform Module for UCS (SPI-based)
UCSX-TPM2-002	Trusted Platform Module 2.0 for UCS servers
<b>Secure Digital Cards</b>	
UCS-SD-128G=	128 GB SD Card for UCS servers
UCS-SD-64G-S=	64 GB SD Card for UCS servers
UCS-SD-32G-S=	32 GB SD Card for UCS servers
UCS-MSTOR-SD=	SD module card (holds up to 2)
<b>M.2 SATA SSDs</b>	
UCS-M2-240GB=	240 GB M.2 SATA SSD
UCS-MSTOR-M2=	M.2 module card (holds up to 2)
<b>Boot-Optimized RAID controller</b>	
UCS-M2-HWRAID =	Cisco Boot optimized M.2 Raid controller
<b>USB 3.0 Drive</b>	
UCS-USBFLSHB-16GB	UCS Servers 16 GB Flash USB Drive
<b>Power Cables</b>	
CAB-C13-C14-2M=	CABASY,WIRE,JUMPER CORD, PWR, 2 Meter, C13/C14,10A/250V
CAB-250V-10A-AR=	Power Cord, SFS, 250V, 10A, Argentina

Table 32 Spare Parts

CAB-9K10A-AU=	Power Cord, 250VAC 10A 3112 Plug, Australia
CAB-250V-10A-CN=	AC Power Cord - 250V, 10A - PRC
CAB-9K10A-EU=	Power Cord, 250VAC 10A CEE 7/7 Plug, EU
CAB-250V-10A-ID=	Power Cord, SFS, 250V, 10A, India
CAB-250V-10A-IS=	Power Cord, SFS, 250V, 10A, Israel
CAB-9K10A-IT=	Power Cord, 250VAC 10A CEI 23-16/VII Plug, Italy
CAB-9K10A-SW=	Power Cord, 250VAC 10A MP232 Plug, Switzerland
CAB-9K10A-UK=	Power Cord, 250VAC 10A BS1363 Plug (13 A fuse), UK
CAB-AC-L620-C13=	AC Power Cord, NEMA L6-20 - C13, 2M/6.5ft
CAB-250V-10A-BR=	Power Cord - 250V, 10A - Brazil

**Software/Firmware****IMC Supervisor**

CIMC-SUP-BASE-K9=	IMC Supervisor One-time Site Installation License
CIMC-SUP-B01=	IMC Supervisor-Branch Mgt SW for C-Series & E-Series up to 100 Svrs
CIMC-SUP-B02=	IMC Supervisor- Branch Mgt SW for C & E-Series up to 250 Svrs
CIMC-SUP-B10=	IMC Supervisor- Branch Mgt SW for C & E-Series up to 1K Svrs
CIMC-SUP-B25=	IMC Supervisor Branch Mgt SW for C & E-Series 25 Svrs
CIMC-SUP-A01=	IMC Supervisor Adv-Branch Mgt SW for C & E-Series 100 Svrs
CIMC-SUP-A02=	IMC Supervisor Adv-Branch Mgt SW for C & E-Series 250 Svrs
CIMC-SUP-A10=	IMC Supervisor Adv-Branch Mgt SW for C & E-Series 1000 Svrs
CIMC-SUP-A25=	IMC Supervisor Adv-Branch Mgt SW for C & E-Series 250 Svrs
EVAL-CIMC-SUP=	EVAL: IMC Supervisor-Branch Mgt SW for C/E-Series - 50 Svrs
EVAL-CIMC-SUP-BAS=	EVAL: IMC Supervisor One-time Site Installation License

**UCS Multi-Domain Manager**

UCS-MDMGR-1S=	UCS Central Per Server License
---------------	--------------------------------

**NOTE:** IF you must order quantity greater than 1 of UCS-MDMGR-1S, you need to reference the UCS Central Per Server Data Sheet to order the standalone PIDs: UCS-MDMGR-LIC= or UCS-MDMGR-1DMN=

**VMware vCenter**

VMW-VCS-STD-1A=	VMware vCenter 6 Server Standard, 1 yr support required
VMW-VCS-STD-3A=	VMware vCenter 6 Server Standard, 3 yr support required
VMW-VCS-STD-5A=	VMware vCenter 6 Server Standard, 5 yr support required

Table 32 Spare Parts

VMW-VCS-FND-1A=	VMware vCenter 6 Server Foundation (3 Host), 1 yr supp reqd
VMW-VCS-FND-3A=	VMware vCenter 6 Server Foundation (3 Host), 3 yr supp reqd
VMW-VCS-FND-5A=	VMware vCenter 6 Server Foundation (3 Host), 5 yr supp reqd
<b>Red Hat</b>	
RHEL-2S2V-1A=	Red Hat Enterprise Linux (1-2 CPU,1-2 VN)
RHEL-2S2V-3A=	Red Hat Enterprise Linux (1-2 CPU,1-2 VN)
RHEL-2S2V-1S=	Red Hat Enterprise Linux (1-2 CPU,1-2 VN)
RHEL-2S2V-3S=	Red Hat Enterprise Linux (1-2 CPU,1-2 VN)
RHEL-2S-HA-1S=	RHEL High Availability (1-2 CPU)
RHEL-2S-HA-3S=	RHEL High Availability (1-2 CPU)
RHEL-2S-RS-1S=	RHEL Resilient Storage (1-2 CPU)
RHEL-2S-RS-3S=	RHEL Resilient Storage (1-2 CPU)
RHEL-2S-SFS-1S=	RHEL Scalable File System (1-2 CPU)
RHEL-2S-SFS-3S=	RHEL Scalable File System (1-
RHEL-2S2V-5A=	Red Hat Enterprise Linux (1-2 CPU,1-2 VN)
RHEL-2S-HA-1A=	RHEL High Availability (1-2 CPU)
RHEL-2S-HA-3A=	RHEL High Availability (1-2 CPU)
RHEL-2S-HA-5A=	RHEL High Availability (1-2 CPU)
RHEL-2S-RS-1A=	RHEL Resilient Storage (1-2 CPU)
RHEL-2S-RS-3A=	RHEL Resilient Storage (1-2 CPU)
RHEL-2S-RS-5A=	RHEL Resilient Storage (1-2 CPU)
RHEL-2S-SFS-1A=	RHEL Scalable File System (1-2 CPU)
RHEL-2S-SFS-3A=	RHEL Scalable File System (1-2 CPU)
RHEL-2S-SFS-5A=	RHEL Scalable File System (1-2 CPU)
<b>Red Hat SAP</b>	
RHEL-SAP-2S2V-1S=	RHEL for SAP Apps (1-2 CPU, 1-2 VN)
RHEL-SAP-2S2V-3S=	RHEL for SAP Apps (1-2 CPU, 1-2 VN)
RHEL-SAPH-2S2V-1S=	RHEL for SAP Hana (1-2 CPU, 1-2 VN)
RHEL-SAPH-2S2V-3S=	RHEL for SAP Hana (1-2 CPU, 1-2 VN)
RHEL-SAPHHAP2S-1S=	RHEL for SAP Hana,HA,SmartM (1-2 CPU &VN)

Table 32 Spare Parts

RHEL-SAPHHAP2S-3S=	RHEL for SAP Hana,HA,SmartM (1-2 CPU &VN)
<b>VMware</b>	
VMW-VSP-STD-1S=	VMware vSphere 6 Standard (1 CPU), 1-yr VMware SnS Reqd
VMW-VSP-STD-3S=	VMware vSphere 6 Standard (1 CPU), 3-yr VMware SnS Reqd
VMW-VSP-EPL-1S=	VMware vSphere 6 Ent Plus (1 CPU), 1-yr VMware SnS Reqd
VMW-VSP-EPL-3S=	VMware vSphere 6 Ent Plus (1 CPU), 3-yr VMware SnS Reqd
VMW-VSP-STD-1A=	VMware vSphere 6 Standard (1 CPU), 1-yr, Support Required
VMW-VSP-STD-3A=	VMware vSphere 6 Standard (1 CPU), 3-yr, Support Required
VMW-VSP-STD-5A=	VMware vSphere 6 Standard (1 CPU), 5-yr, Support Required
VMW-VSP-EPL-3A=	VMware vSphere 6 Ent Plus (1 CPU), 3-yr, Support Required
VMW-VSP-EPL-1A=	VMware vSphere 6 Ent Plus (1 CPU), 1-yr, Support Required
VMW-VSP-EPL-5A=	VMware vSphere 6 Ent Plus (1 CPU), 5-yr, Support Required
<b>SLES and SAP</b>	
SLES-SAP-2S2V-1A=	SLES for SAP Apps (1-2 CPU, 1-2 VM)
SLES-SAP-2SUV-1A=	SLES for SAP Apps (1-2 CPU, Unl VM)
SLES-SAP-2S2V-3A=	SLES for SAP Apps (1-2 CPU, 1-2 VM)
SLES-SAP-2SUV-3A=	SLES for SAP Apps (1-2 CPU, Unl VM)
SLES-SAP-2S2V-5A=	SLES for SAP Apps (1-2 CPU, 1-2 VM)
SLES-SAP-2SUV-5A=	SLES for SAP Apps (1-2 CPU, Unl VM)
SLES-SAP-2S2V-1S=	SLES for SAP Apps (1-2 CPU, 1-2 VM)
SLES-SAP-2SUV-1S=	SLES for SAP Apps (1-2 CPU, Unl VM)
SLES-SAP-2S2V-3S=	SLES for SAP Apps (1-2 CPU, 1-2 VM)
SLES-SAP-2SUV-3S=	SLES for SAP Apps (1-2 CPU, Unl VM)
SLES-SAP-2S2V-5S=	SLES for SAP Apps (1-2 CPU, 1-2 VM)
SLES-SAP-2SUV-5S=	SLES for SAP Apps (1-2 CPU, Unl VM)
<b>SUSE</b>	
SLES-2S2V-1A=	SUSE Linux Enterprise Svr (1-2 CPU,1-2 VM)
SLES-2SUV-1A=	SUSE Linux Enterprise Svr (1-2 CPU,Unl VM)
SLES-2S2V-3A=	SUSE Linux Enterprise Svr (1-2 CPU,1-2 VM)
SLES-2SUV-3A=	SUSE Linux Enterprise Svr (1-2 CPU,Unl VM)

Table 32 Spare Parts

SLES-2S2V-5A=	SUSE Linux Enterprise Svr (1-2 CPU, 1-2 VM)
SLES-2SUV-5A=	SUSE Linux Enterprise Svr (1-2 CPU, Uni VM)
SLES-2S2V-1S=	SUSE Linux Enterprise Svr (1-2 CPU, 1-2 VM)
SLES-2SUV-1S=	SUSE Linux Enterprise Svr (1-2 CPU, Uni VM)
SLES-2S2V-3S=	SUSE Linux Enterprise Svr (1-2 CPU, 1-2 VM)
SLES-2SUV-3S=	SUSE Linux Enterprise Svr (1-2 CPU, Uni VM)
SLES-2S2V-5S=	SUSE Linux Enterprise Svr (1-2 CPU, 1-2 VM)
SLES-2SUV-5S=	SUSE Linux Enterprise Svr (1-2 CPU, Uni VM)
SLES-2S-HA-1S=	SUSE Linux High Availability Ext (1-2 CPU)
SLES-2S-HA-3S=	SUSE Linux High Availability Ext (1-2 CPU)
SLES-2S-HA-5S=	SUSE Linux High Availability Ext (1-2 CPU)
SLES-2S-GC-1S=	SUSE Linux GEO Clustering for HA (1-2 CPU)
SLES-2S-GC-3S=	SUSE Linux GEO Clustering for HA (1-2 CPU)
SLES-2S-GC-5S=	SUSE Linux GEO Clustering for HA (1-2 CPU)
SLES-2S-LP-1S=	SUSE Linux Live Patching Add-on (1-2 CPU)
SLES-2S-LP-3S=	SUSE Linux Live Patching Add-on (1-2 CPU)

**Notes:**

1. NVMe drives require the following storage controller in the front mezzanine slot:  
UCSB-LSTOR-PT
2. For HDD or SSD drives to be in a RAID group, two identical HDDs or SSDs must be used in the group.
3. If HDD or SSD are in JBOD Mode, the drives do not need to be identical.

Please refer to the [UCS B200 M5 Installation Guide](#) for installation procedures.

## UPGRADING or REPLACING CPUs



**NOTE:** Before servicing any CPU, do the following:

- Decommission and power off the server.
- Slide the B200 M5 out from its chassis.
- Remove the top cover.

To replace an existing CPU, follow these steps:

(1) Have the following tools and materials available for the procedure:

- T-30 Torx driver—Supplied with replacement CPU.
- #1 flat-head screwdriver—Supplied with replacement CPU.
- CPU assembly tool—Supplied with replacement CPU. Can be ordered separately as Cisco PID UCS-CPUAT=.
- Heatsink cleaning kit—Supplied with replacement CPU. Can be ordered separately as Cisco PID UCSX-HSCK=.
- Thermal interface material (TIM)—Syringe supplied with replacement CPU. Can be ordered separately as Cisco PID UCS-CPU-TIM=.

(2) Order the appropriate replacement CPU from *Available CPUs on page 9*.

(3) Carefully remove and replace the CPU and heatsink in accordance with the instructions found in “Cisco UCS B200 M5 Blade Server Installation and Service Note,” found at:

[https://www.cisco.com/c/en/us/td/docs/unified\\_computing/ucs/hw/blade-servers/B200M5/B200M5\\_chapter\\_011.html#id\\_104667](https://www.cisco.com/c/en/us/td/docs/unified_computing/ucs/hw/blade-servers/B200M5/B200M5_chapter_011.html#id_104667).

To add a new CPU, follow these steps:

(1) Have the following tools and materials available for the procedure:

- T-30 Torx driver—Supplied with new CPU.
- #1 flat-head screwdriver—Supplied with new CPU
- CPU assembly tool—Supplied with new CPU. Can be ordered separately as Cisco PID UCS-CPUAT=
- Thermal interface material (TIM)—Syringe supplied with replacement CPU. Can be ordered separately as Cisco PID UCS-CPU-TIM=

(2) Order the appropriate new CPU from *Table 3 on page 9*.

(3) Order one heat sink for each new CPU. Order PID UCSB-HS-M5-F= for the front CPU socket and PID UCSB-HS-M5-R= for the rear CPU socket.



(4) Carefully install the CPU and heatsink in accordance with the instructions found in “Cisco UCS B200 M5 Blade Server Installation and Service Note,” found at: [https://www.cisco.com/c/en/us/td/docs/unified\\_computing/ucs/hw/blade-servers/B200M5/B200M5\\_chapter\\_011.html#id\\_104667](https://www.cisco.com/c/en/us/td/docs/unified_computing/ucs/hw/blade-servers/B200M5/B200M5_chapter_011.html#id_104667).

## UPGRADING or REPLACING MEMORY



**NOTE:** Before servicing any DIMM or PMEM, do the following:

- Decommission and power off the server.
- Remove the top cover from the server
- Slide the server out the front of the chassis.

To add or replace DIMMs or PMEMs, follow these steps:

- (1) Order new DIMMs or PMEMs as needed from [Table 4 on page 17](#).
- (2) Order DIMM/PMEM blanks as needed (PID UCS-DIMM-BLK=)
- (3) Open both connector latches and remove and replace the DIMM/PMEM or blank as needed.

Figure 7 Replacing Memory

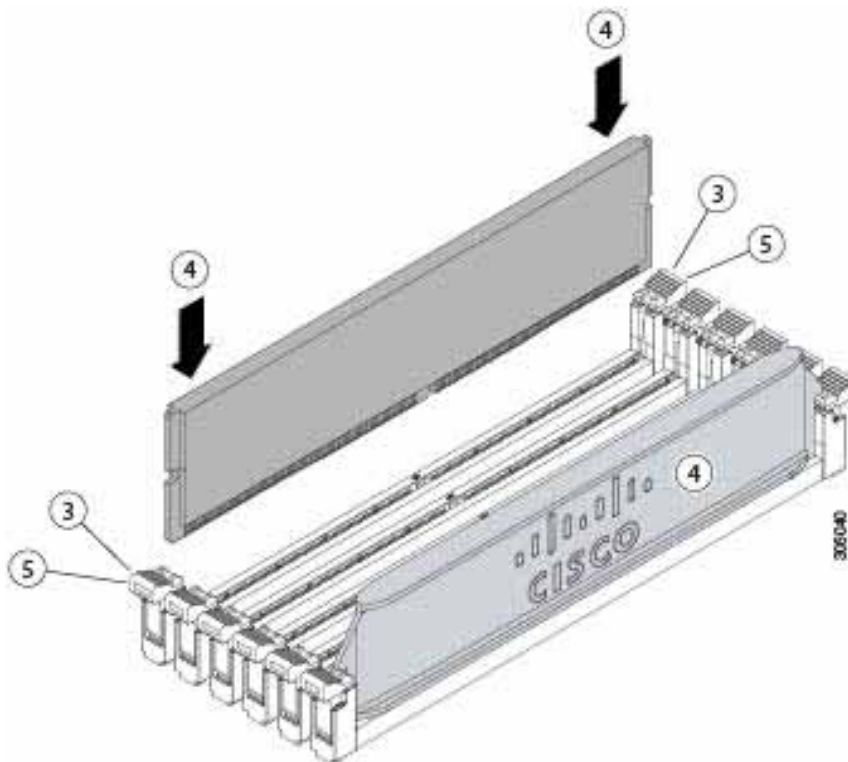

- (4) Press evenly on both ends of the DIMM/PMEM until it clicks into place in its slot.



**NOTE:** Ensure that the notch in the DIMM/PMEM aligns with the slot. If the notch is misaligned, it is possible to damage the DIMM/PMEM, the slot, or both.

---

- (5) Press the connector latches inward slightly to seat them fully.
- (6) Populate all slots with a DIMM, PMEM, or DIMM blank. A slot cannot be empty.

For additional details on replacing or upgrading DIMMs, see “Cisco UCS B200 M5 Blade Server Installation and Service Note,” found at [https://www.cisco.com/c/en/us/td/docs/unified\\_computing/ucs/hw/blade-servers/B200M5/B200M5\\_chapter\\_011.html#concept\\_on5\\_vzl\\_kz](https://www.cisco.com/c/en/us/td/docs/unified_computing/ucs/hw/blade-servers/B200M5/B200M5_chapter_011.html#concept_on5_vzl_kz).

## DISCONTINUED EOL PRODUCTS

Below is the list of parts were previously available for this product and are no longer sold. Please refer to the EOL bulletin links shown in [Table 33](#) to determine if the part is still supported and if there is a replacement part.

Table 33 EOL Products

EOS option PID	Description	EOL Bulletin Link
<b>DRIVES</b>		
<b>Enterprise Value SSDs</b>		
UCS-SD150GBKS4-EV	150 GB 2.5 inch Enterprise Value 6G SATA SSD	<a href="https://www.cisco.com/c/en/us/products/collateral/servers-unified-computing/ucs-c-series-rack-servers/eos-eol-notice-c51-740779.html">https://www.cisco.com/c/en/us/products/collateral/servers-unified-computing/ucs-c-series-rack-servers/eos-eol-notice-c51-740779.html</a>
UCS-SD480GBKS4-EV	480 GB 2.5 inch Enterprise Value 6G SATA SSD	<a href="https://www.cisco.com/c/en/us/products/collateral/servers-unified-computing/ucs-c-series-rack-servers/eos-eol-notice-c51-740779.html">https://www.cisco.com/c/en/us/products/collateral/servers-unified-computing/ucs-c-series-rack-servers/eos-eol-notice-c51-740779.html</a>
UCS-SD960GKS4-EV	960GB 2.5 inch Enterprise Value 6G SATA SSD	<a href="https://www.cisco.com/c/en/us/products/collateral/servers-unified-computing/ucs-c-series-rack-servers/eos-eol-notice-c51-740779.html">https://www.cisco.com/c/en/us/products/collateral/servers-unified-computing/ucs-c-series-rack-servers/eos-eol-notice-c51-740779.html</a>
UCS-SD16TBKS4-EV	1.6TB 2.5 inch Enterprise Value 6G SATA SSD	<a href="https://www.cisco.com/c/en/us/products/collateral/servers-unified-computing/ucs-c-series-rack-servers/eos-eol-notice-c51-740779.html">https://www.cisco.com/c/en/us/products/collateral/servers-unified-computing/ucs-c-series-rack-servers/eos-eol-notice-c51-740779.html</a>
HX-SD480GBKSS-EV	480GB 2.5 in Enterprise Value 6G SATA SSD(1FWPD)-PM86	<a href="https://www.cisco.com/c/en/us/products/collateral/servers-unified-computing/ucs-b-series-blade-servers/eos-eol-notice-c51-742066.html">https://www.cisco.com/c/en/us/products/collateral/servers-unified-computing/ucs-b-series-blade-servers/eos-eol-notice-c51-742066.html</a>
UCS-SD240GBKS4-EV	240GB 2.5 inch Enterprise Value 6G SATA SSD	<a href="https://www.cisco.com/c/en/us/products/collateral/servers-unified-computing/ucs-b-series-blade-servers/eos-eol-notice-c51-742066.html">https://www.cisco.com/c/en/us/products/collateral/servers-unified-computing/ucs-b-series-blade-servers/eos-eol-notice-c51-742066.html</a>
UCS-SD480GBKSS-EV	480GB 2.5 in Enterprise Value 6G SATA SSD(1FWPD)-PM86	<a href="https://www.cisco.com/c/en/us/products/collateral/servers-unified-computing/ucs-b-series-blade-servers/eos-eol-notice-c51-742066.html">https://www.cisco.com/c/en/us/products/collateral/servers-unified-computing/ucs-b-series-blade-servers/eos-eol-notice-c51-742066.html</a>
<b>Enterprise Performance SSDs</b>		
UCS-SD200G12S3-EP	200GB 2.5 inch Enterprise performance 6G SATA SSD(3 FWPD)	<a href="https://www.cisco.com/c/en/us/products/collateral/servers-unified-computing/ucs-c-series-rack-servers/eos-eol-notice-c51-739513.html">https://www.cisco.com/c/en/us/products/collateral/servers-unified-computing/ucs-c-series-rack-servers/eos-eol-notice-c51-739513.html</a>
UCS-SD480G12S3-EP	480GB 2.5 inch Ent. Performance 6GSATA SSD(3X endurance)	<a href="https://www.cisco.com/c/en/us/products/collateral/servers-unified-computing/ucs-c-series-rack-servers/eos-eol-notice-c51-739513.html">https://www.cisco.com/c/en/us/products/collateral/servers-unified-computing/ucs-c-series-rack-servers/eos-eol-notice-c51-739513.html</a>
UCS-SD800G12S3-EP	800GB 2.5 inch Enterprise performance 6G SATA SSD(3 FWPD)	<a href="https://www.cisco.com/c/en/us/products/collateral/servers-unified-computing/ucs-c-series-rack-servers/eos-eol-notice-c51-739513.html">https://www.cisco.com/c/en/us/products/collateral/servers-unified-computing/ucs-c-series-rack-servers/eos-eol-notice-c51-739513.html</a>
UCS-SD16TB12S3-EP	1.6TB 2.5 inch Ent. Performance 6GSATA SSD(3X endurance)	<a href="https://www.cisco.com/c/en/us/products/collateral/servers-unified-computing/ucs-c-series-rack-servers/eos-eol-notice-c51-739513.html">https://www.cisco.com/c/en/us/products/collateral/servers-unified-computing/ucs-c-series-rack-servers/eos-eol-notice-c51-739513.html</a>
UCS-SD400G12S4-EP	400 GB 2.5 inch Ent Performance 12G SAS SSD (10X endurance) (SanDisk Lightning II)	<a href="https://www.cisco.com/c/en/us/products/collateral/servers-unified-computing/ucs-c-series-rack-servers/eos-eol-notice-c51-739513.html">https://www.cisco.com/c/en/us/products/collateral/servers-unified-computing/ucs-c-series-rack-servers/eos-eol-notice-c51-739513.html</a>

Table 33 EOL Products (*continued*)

EOS option PID	Description	EOL Bulletin Link
<b>NVMe</b>		
UCSB-NVMELW-I500	500GB 2.5in U.2 Intel P4501 NVMe Med. Perf. Value Endurance	<a href="https://www.cisco.com/c/en/us/products/collateral/servers-unified-computing/ucs-c-series-rack-servers/eos-eol-notice-c51-742509.html">https://www.cisco.com/c/en/us/products/collateral/servers-unified-computing/ucs-c-series-rack-servers/eos-eol-notice-c51-742509.html</a>
UCSB-NVMEXP-I375	375GB 2.5in Intel Optane NVMe Extreme Perf	<a href="https://www.cisco.com/c/en/us/products/collateral/servers-unified-computing/ucs-c-series-rack-servers/eos-eol-notice-c51-742509.html">https://www.cisco.com/c/en/us/products/collateral/servers-unified-computing/ucs-c-series-rack-servers/eos-eol-notice-c51-742509.html</a>
UCSB-NVMELW-I1000	Cisco 2.5" U.2 1 TB Intel P4501 NVMe Med. Perf. Value Endurance	<a href="https://www.cisco.com/c/en/us/products/collateral/servers-unified-computing/ucs-c-series-rack-servers/eos-eol-notice-c51-742509.html">https://www.cisco.com/c/en/us/products/collateral/servers-unified-computing/ucs-c-series-rack-servers/eos-eol-notice-c51-742509.html</a>
UCSB-NVMEHW-I1000	Cisco 2.5" U.2 1 TB Intel P4500 NVMe High Perf. Value Endurance	<a href="https://www.cisco.com/c/en/us/products/collateral/servers-unified-computing/ucs-c-series-rack-servers/eos-eol-notice-c51-742509.html">https://www.cisco.com/c/en/us/products/collateral/servers-unified-computing/ucs-c-series-rack-servers/eos-eol-notice-c51-742509.html</a>
UCSB-NVMELW-I2000	Cisco 2.5" U.2 2 TB Intel P4501 NVMe Med. Perf. Value Endurance	<a href="https://www.cisco.com/c/en/us/products/collateral/servers-unified-computing/ucs-c-series-rack-servers/eos-eol-notice-c51-742509.html">https://www.cisco.com/c/en/us/products/collateral/servers-unified-computing/ucs-c-series-rack-servers/eos-eol-notice-c51-742509.html</a>
UCSB-NVMEHW-I2000	Cisco 2.5" U.2 2.0 TB Intel P4600 NVMe High Perf. High Endur (Intel)	<a href="https://www.cisco.com/c/en/us/products/collateral/servers-unified-computing/ucs-c-series-rack-servers/eos-eol-notice-c51-742823.html">https://www.cisco.com/c/en/us/products/collateral/servers-unified-computing/ucs-c-series-rack-servers/eos-eol-notice-c51-742823.html</a>
UCSB-NVMEHW-I1600	Cisco 2.5" U.2 1.6 TB Intel P4600 NVMe High Perf. High Endurance	<a href="https://www.cisco.com/c/en/us/products/collateral/servers-unified-computing/ucs-c-series-rack-servers/eos-eol-notice-c51-742823.html">https://www.cisco.com/c/en/us/products/collateral/servers-unified-computing/ucs-c-series-rack-servers/eos-eol-notice-c51-742823.html</a>
UCSB-NVMEHW-I4000	Cisco 2.5" U.2 4 TB Intel P4500 NVMe High Perf. Value Endurance	<a href="https://www.cisco.com/c/en/us/products/collateral/servers-unified-computing/ucs-c-series-rack-servers/eos-eol-notice-c51-742509.html">https://www.cisco.com/c/en/us/products/collateral/servers-unified-computing/ucs-c-series-rack-servers/eos-eol-notice-c51-742509.html</a>
UCSB-NVMEHW-I2TBV	2TB 2.5in U.2 Intel P4500 NVMe High Perf Value Endurance	<a href="https://www.cisco.com/c/en/us/products/collateral/servers-unified-computing/ucs-c-series-rack-servers/eos-eol-notice-c51-742823.html">https://www.cisco.com/c/en/us/products/collateral/servers-unified-computing/ucs-c-series-rack-servers/eos-eol-notice-c51-742823.html</a>
UCSB-NVMEHW-I3200	3.2TB 2.5in U.2 Intel P4600 NVMe High Perf High Endurance	<a href="https://www.cisco.com/c/en/us/products/collateral/servers-unified-computing/ucs-c-series-rack-servers/eos-eol-notice-c51-742823.html">https://www.cisco.com/c/en/us/products/collateral/servers-unified-computing/ucs-c-series-rack-servers/eos-eol-notice-c51-742823.html</a>
<b>SED</b>		
UCS-SD480GBHBNK9	480GB Enterprise value SAS SSD (1X FWPD, SED)	<a href="https://www.cisco.com/c/en/us/products/collateral/servers-unified-computing/ucs-c-series-rack-servers/eos-eol-notice-c51-742823.html">https://www.cisco.com/c/en/us/products/collateral/servers-unified-computing/ucs-c-series-rack-servers/eos-eol-notice-c51-742823.html</a>
UCS-SD38TBHBNK9	3.8TB Enterprise value SAS SSD (1X FWPD, SED)	<a href="https://www.cisco.com/c/en/us/products/collateral/servers-unified-computing/ucs-c-series-rack-servers/eos-eol-notice-c51-742823.html">https://www.cisco.com/c/en/us/products/collateral/servers-unified-computing/ucs-c-series-rack-servers/eos-eol-notice-c51-742823.html</a>
<b>MEMORY</b>		
UCS-MR-X16G2RS-H	16GB DDR4-2666-MHz RDIMM/PC4-21300/dual rank/x4/1.2v	<a href="https://www.cisco.com/c/en/us/products/collateral/servers-unified-computing/ucs-c-series-rack-servers/eos-eol-notice-c51-740780.html">https://www.cisco.com/c/en/us/products/collateral/servers-unified-computing/ucs-c-series-rack-servers/eos-eol-notice-c51-740780.html</a>
<b>MEZZANINE ADAPTERS</b>		
UCSB-F-H32003	UCS Blade PCIe/NVMe Storage Mezz 3200GB Medium Endurance	<a href="https://www.cisco.com/c/en/us/products/collateral/servers-unified-computing/ucs-c-series-rack-servers/eos-eol-notice-c51-739513.html">https://www.cisco.com/c/en/us/products/collateral/servers-unified-computing/ucs-c-series-rack-servers/eos-eol-notice-c51-739513.html</a>

Table 33 EOL Products (*continued*)

EOS option PID	Description	EOL Bulletin Link
UCSB-F-H5607	UCS Blade PCIe/NVMe Storage Mezz 560GB High Endurance	<a href="https://www.cisco.com/c/en/us/products/collateral/servers-unified-computing/ucs-c-series-rack-servers/eos-eol-notice-c51-739513.html">https://www.cisco.com/c/en/us/products/collateral/servers-unified-computing/ucs-c-series-rack-servers/eos-eol-notice-c51-739513.html</a>
<b>Microsoft Windows server</b>		
MSWS-16-ST16C	Windows Server 2016 Standard (16 Cores/2 VMs)	<a href="https://www.cisco.com/c/en/us/products/servers-unified-computing/ucs-c-series-rack-servers/eos-eol-notice-c51-743145.html">https://www.cisco.com/c/en/us/products/servers-unified-computing/ucs-c-series-rack-servers/eos-eol-notice-c51-743145.html</a>
MSWS-16-ST24C	Windows Server 2016 Standard (24 Cores/2 VMs)	<a href="https://www.cisco.com/c/en/us/products/servers-unified-computing/ucs-c-series-rack-servers/eos-eol-notice-c51-743145.html">https://www.cisco.com/c/en/us/products/servers-unified-computing/ucs-c-series-rack-servers/eos-eol-notice-c51-743145.html</a>
MSWS-16-ST16C-NS	Windows Server 2016 Standard (16 Cores/2 VMs) - No Cisco SVC	<a href="https://www.cisco.com/c/en/us/products/servers-unified-computing/ucs-c-series-rack-servers/eos-eol-notice-c51-743145.html">https://www.cisco.com/c/en/us/products/servers-unified-computing/ucs-c-series-rack-servers/eos-eol-notice-c51-743145.html</a>
MSWS-16-ST24C-NS	Windows Server 2016 Standard (24 Cores/2 VMs) - No Cisco SVC	<a href="https://www.cisco.com/c/en/us/products/servers-unified-computing/ucs-c-series-rack-servers/eos-eol-notice-c51-743145.html">https://www.cisco.com/c/en/us/products/servers-unified-computing/ucs-c-series-rack-servers/eos-eol-notice-c51-743145.html</a>
MSWS-16-DC16C	Windows Server 2016 Data Center (16 Cores/Unlimited VMs)	<a href="https://www.cisco.com/c/en/us/products/servers-unified-computing/ucs-c-series-rack-servers/eos-eol-notice-c51-743145.html">https://www.cisco.com/c/en/us/products/servers-unified-computing/ucs-c-series-rack-servers/eos-eol-notice-c51-743145.html</a>
MSWS-16-DC24C	Windows Server 2016 Data Center (24 Cores/Unlimited VMs)	<a href="https://www.cisco.com/c/en/us/products/servers-unified-computing/ucs-c-series-rack-servers/eos-eol-notice-c51-743145.html">https://www.cisco.com/c/en/us/products/servers-unified-computing/ucs-c-series-rack-servers/eos-eol-notice-c51-743145.html</a>
MSWS-16-DC16C-NS	Windows Server 2016 DC (16 Cores/Unlim VMs) - No Cisco SVC	<a href="https://www.cisco.com/c/en/us/products/servers-unified-computing/ucs-c-series-rack-servers/eos-eol-notice-c51-743145.html">https://www.cisco.com/c/en/us/products/servers-unified-computing/ucs-c-series-rack-servers/eos-eol-notice-c51-743145.html</a>
MSWS-16-DC24C-NS	Windows Server 2016 DC (24 Cores/Unlim VMs) - No Cisco SVC	<a href="https://www.cisco.com/c/en/us/products/servers-unified-computing/ucs-c-series-rack-servers/eos-eol-notice-c51-743145.html">https://www.cisco.com/c/en/us/products/servers-unified-computing/ucs-c-series-rack-servers/eos-eol-notice-c51-743145.html</a>
<b>OS Media</b>		
MSWS-16-ST16C-RM	Windows Server 2016 Std (16 Cores/2 VMs) - Recovery Media	<a href="https://www.cisco.com/c/en/us/products/servers-unified-computing/ucs-c-series-rack-servers/eos-eol-notice-c51-743145.html">https://www.cisco.com/c/en/us/products/servers-unified-computing/ucs-c-series-rack-servers/eos-eol-notice-c51-743145.html</a>
MSWS-16-ST24C-RM	Windows Server 2016 Std (24 Cores/2 VMs) - Recovery Media	<a href="https://www.cisco.com/c/en/us/products/servers-unified-computing/ucs-c-series-rack-servers/eos-eol-notice-c51-743145.html">https://www.cisco.com/c/en/us/products/servers-unified-computing/ucs-c-series-rack-servers/eos-eol-notice-c51-743145.html</a>
MSWS-16-DC16C-RM	Windows Server 2016 DC (16 Cores/Unlim VMs) - Recovery Media	<a href="https://www.cisco.com/c/en/us/products/servers-unified-computing/ucs-c-series-rack-servers/eos-eol-notice-c51-743145.html">https://www.cisco.com/c/en/us/products/servers-unified-computing/ucs-c-series-rack-servers/eos-eol-notice-c51-743145.html</a>
MSWS-16-DC24C-RM	Windows Server 2016 DC (24 Cores/Unlim VMs) - Recovery Media	<a href="https://www.cisco.com/c/en/us/products/servers-unified-computing/ucs-c-series-rack-servers/eos-eol-notice-c51-743145.html">https://www.cisco.com/c/en/us/products/servers-unified-computing/ucs-c-series-rack-servers/eos-eol-notice-c51-743145.html</a>
<b>UCSM Software</b>		
N20-FW015	UCS 5108 Blade Chassis FW Package 3.2(2)	<a href="https://www.cisco.com/c/en/us/products/collateral/servers-unified-computing/ucs-manager/eos-eol-notice-c51-743144.html">https://www.cisco.com/c/en/us/products/collateral/servers-unified-computing/ucs-manager/eos-eol-notice-c51-743144.html</a>

## TECHNICAL SPECIFICATIONS

### Dimensions and Weight

Table 34 UCS B200 M5 Dimensions and Weight

Parameter	Value
Height	1.95 in. (50 mm)
Width	8.00 in.(203 mm)
Depth	24.4 in. (620 mm)
Weight	<ul style="list-style-type: none"> <li>■ Base server weight = 9.51 lbs (4.31 kg) (no HDDs, no CPUs, no DIMMs, no mezzanine adapters or memory)</li> <li>■ Minimally configured server weight = 11.29 lbs (5.12 kg) (no HDDs, 1 CPU, 8 DIMMs, VIC 1340 but no additional mezzanine adapter)</li> <li>■ Fully configured server weight = 16 lbs (7.25 kg) (2 HDDs, 2 CPUs, 24 DIMMs, VIC 1340 and additional mezzanine adapter both populated)</li> </ul>

### Power Specifications

For configuration-specific power specifications, use the Cisco UCS Power Calculator at: ■

<http://ucspowercalc.cisco.com>

**NOTE:** When using 256 GB DDR DIMMs (UCS-ML-256G8RT-H) in this server, the blade-level power capping must be set to 550 W. For information about blade-level power capping, see the Power Capping and Power Management chapter in the Cisco UCS Manager Server Management Guide for your release: [Cisco UCS Manager Configuration Guides](#)



**Americas Headquarters**  
Cisco Systems, Inc.  
San Jose, CA

**Asia Pacific Headquarters**  
Cisco Systems (USA) Pte. Ltd.  
Singapore

**Europe Headquarters**  
Cisco Systems International BV Amsterdam,  
The Netherlands

Cisco has more than 200 offices worldwide. Addresses, phone numbers, and fax numbers are listed on the Cisco Website at [www.cisco.com/go/offices](http://www.cisco.com/go/offices).

Cisco and the Cisco Logo are trademarks of Cisco Systems, Inc. and/or its affiliates in the U.S. and other countries. A listing of Cisco's trademarks can be found at [www.cisco.com/go/trademarks](http://www.cisco.com/go/trademarks). Third party trademarks mentioned are the property of their respective owners. The use of the word partner does not imply a partnership relationship between Cisco and any other company. (1005R)