



HP PageWide Enterprise Color MFP 780, 785

User Guide

Copyright and License

© Copyright 2017 HP Development Company, L.P.

Reproduction, adaptation, or translation without prior written permission is prohibited, except as allowed under the copyright laws.

The information contained herein is subject to change without notice.

The only warranties for HP products and services are set forth in the express warranty statements accompanying such products and services. Nothing herein should be construed as constituting an additional warranty. HP shall not be liable for technical or editorial errors or omissions contained herein.

Edition 1, 9/2017

Trademark Credits

Adobe®, Adobe Photoshop®, Acrobat®, and PostScript® are trademarks of Adobe Systems Incorporated.

Apple and the Apple logo are trademarks of Apple Inc., registered in the U.S. and other countries.

OS X is a trademark of Apple Inc., registered in the U.S. and other countries.

AirPrint is a trademark of Apple Inc., registered in the U.S. and other countries.

Google™ is a trademark of Google Inc.

Microsoft®, Windows®, Windows® XP, and Windows Vista® are U.S. registered trademarks of Microsoft Corporation.

UNIX® is a registered trademark of The Open Group.

Table of contents

1 Printer overview	1
Caution icons	2
Printer views	3
Printer front view	3
Printer back view and interface ports	4
Control-panel view	5
How to use the touchscreen control panel	7
Printer specifications	8
Technical specifications	8
Supported operating systems	10
Mobile printing solutions	12
Printer dimensions	12
Power consumption, electrical specifications, and acoustic emissions	14
Operating environment range	14
Printer hardware setup and software installation	15
2 Paper trays	17
Load paper to Tray 1 (multipurpose tray)	18
Introduction	18
Tray 1 paper orientation	19
Use alternative letterhead mode	24
Enable Alternative Letterhead Mode by using the printer control-panel menus	24
Load paper to Tray 2	25
Introduction	25
Tray 2 and the 550-sheet trays paper orientation	27
Use alternative letterhead mode	31
Enable Alternative Letterhead Mode by using the printer control-panel menus	31
Load the 4,000-sheet high-capacity input (HCI) tray	32
Introduction	32
HCI paper orientation	34
Use alternative letterhead mode	35
Enable Alternative Letterhead Mode by using the printer control-panel menus	36

Load and print envelopes	37
Introduction	37
Print envelopes	37
Envelope orientation	37
Load and print labels	39
Introduction	39
Manually feed labels	39
Label orientation	40
Configure stapling (785zs model only)	41
Configure the default staple location	41
Configure the operation mode	42
3 Supplies, accessories, and parts	45
Order supplies, accessories, and parts	46
Ordering	46
Supplies and accessories	46
Maintenance/long-life consumables (LLC)	47
Customer self-repair parts	47
Replace the cartridges	50
Introduction	50
Cartridge information	50
Remove and replace the cartridges	51
Replace the service fluid container	54
Introduction	54
Remove and replace the service fluid container	54
Replace the staple cartridge (785zs model only)	58
4 Print	61
Print tasks (Windows)	62
How to print (Windows)	62
Automatically print on both sides (Windows)	62
Manually print on both sides (Windows)	63
Print multiple pages per sheet (Windows)	63
Select the paper type (Windows)	64
Additional print tasks	65
Print tasks (OS X)	66
How to print (OS X)	66
Automatically print on both sides (OS X)	66
Manually print on both sides (OS X)	66
Print multiple pages per sheet (OS X)	67
Select the paper type (OS X)	67

Additional print tasks	67
Store print jobs on the printer to print later or print privately	68
Introduction	68
Create a stored job (Windows)	68
Create a stored job (OS X)	69
Print a stored job	70
Delete a stored job	70
Delete a job that is stored on the printer	70
Change the job storage limit	70
Information sent to printer for Job Accounting purposes	71
Mobile printing	72
Introduction	72
Wi-Fi Direct and NFC Connect and Print	72
HP ePrint via email	73
HP ePrint software	74
AirPrint	74
Android embedded printing	74
Print from the USB port	76
Introduction	76
Enable the USB port for printing	76
Print USB documents	77
5 Copy	79
Make a copy	80
Copy on both sides (duplex)	82
Additional copy tasks	84
6 Scan	85
Set up Scan to Email	86
Introduction	86
Before you begin	86
Step one: Access the HP Embedded Web Server (EWS)	86
Step two: Configure the Network Identification settings	87
Step three: Configure the Scan to Email feature	88
Method one: Basic configuration using the Email Setup Wizard	88
Method two: Advanced configuration using the Email Setup	92
Step four: Configure the Quick Sets (optional)	96
Step five: Set up Scan to Email to use Office 365 Outlook (optional)	97
Introduction	97
Configure the outgoing email server (SMTP) to send an email from an Office 365 Outlook account	97

Set up Scan to Network Folder	99
Introduction	99
Before you begin	99
Step one: Access the HP Embedded Web Server	99
Step two: Set up Scan to Network Folder	100
Method one: Use the Scan to Network Folder Wizard	100
Method two: Use Scan to Network Folder Setup	101
Step one: Begin the configuration	101
Step two: Configure the Scan to Network Folder settings	101
Step three: Complete the configuration	109
Set up Scan to USB Drive	110
Introduction	110
Step one: Access the HP Embedded Web Server	110
Step two: Enable Scan to USB Drive	111
Step three: Configure the Quick Sets (optional)	111
Default scan settings for Scan to USB Drive setup	112
Default file settings for Scan to USB Drive setup	112
Set up Scan to SharePoint® (Flow models only)	114
Introduction	114
Before you begin	114
Step one: Access the HP Embedded Web Server (EWS)	114
Step two: Enable Scan to SharePoint® and create a Scan to SharePoint Quick Set	115
Quick set scan settings and options for Scan to SharePoint®	116
Scan to email	119
Introduction	119
Scan to email	119
Scan to network folder	122
Introduction	122
Scan to network folder	122
Scan to USB drive	124
Introduction	124
Scan to USB drive	124
Scan to SharePoint	126
Introduction	126
Scan to SharePoint	126
Scan to job storage	128
Introduction	128
Scan to job storage on the printer	128
Print from job storage on the printer	130
HP JetAdvantage business solutions	131
Additional scan tasks	132

7 Fax	133
Set up fax	134
Introduction	134
Set up fax by using the printer control panel	134
Change fax configurations	135
Fax dialing settings	135
General fax send settings	136
Fax receive settings	136
Send a fax	138
Additional fax tasks	140
8 Manage the printer	141
Advanced configuration with the HP Embedded Web Server (EWS)	142
Introduction	142
How to access the HP Embedded Web Server (EWS)	142
HP Embedded Web Server features	143
Information tab	143
General tab	144
Copy/Print tab	145
Scan/Digital Send tab	146
Fax tab	147
Troubleshooting tab	147
Security tab	148
HP Web Services tab	148
Networking tab	148
Other Links list	150
Create a Quick Set	151
Introduction	151
Step one: Access the HP Embedded Web Server (EWS)	151
Step two: Add and manage Quick Sets	152
Add a Quick Set	152
Edit a Quick Set	153
Copy a Quick Set	153
Remove a Quick Set	154
Quick Set settings and options	154
Example Quick Sets	159
Configure IP network settings	161
Printer sharing disclaimer	161
View or change network settings	161
Rename the printer on a network	161
Manually configure IPv4 TCP/IP parameters from the control panel	162

Manually configure IPv6 TCP/IP parameters from the control panel	162
Link speed and duplex settings	163
Printer security features	164
Introduction	164
Security statements	164
Assign an administrator password	164
IP Security	165
Lock the formatter	165
Encryption support: HP High Performance Secure Hard Disks	165
Energy-conservation settings	166
Introduction	166
Set the sleep timer and configure the printer to use 1 watt or less of power	166
Set the sleep schedule	166
HP Web Jetadmin	168
Software and firmware updates	169
9 Solve problems	171
Customer support	172
Control panel help system	173
Restore factory settings	174
Introduction	174
Method one: Restore factory settings from the printer control panel	174
Method two: Restore factory settings from the HP Embedded Web Server (network-connected printers only)	174
A “Cartridge is low” or “Cartridge is very low” message displays on the printer control panel	175
Change the “Very Low” settings	175
For printers with fax capability	175
Order supplies	176
Printer does not pick up paper or misfeeds	177
Introduction	177
The printer does not pick up paper	177
The printer picks up multiple sheets of paper	179
The document feeder jams, skews, or picks up multiple sheets of paper	183
Clear paper jams	184
Introduction	184
Paper jam locations	185
Auto-navigation for clearing paper jams	186
Experiencing frequent or recurring paper jams?	186
Clear paper jams in the document feeder	187
Clear paper jams in Tray 1	189
Clear paper jams in Tray 2	192

Clear paper jams in Tray 3	194
Clear paper jams in the output bin	198
Clear paper jams in the duplexer	200
Clear paper jams in the 3x550-sheet trays	201
Clear paper jams in the 4,000-sheet high-capacity input (HCI) tray	204
Clear paper jams in the inner finisher (785zs model only)	208
Clear staple jams (785zs model only)	210
Improve print quality	212
Introduction	212
Check the cartridge status	212
Update the printer firmware	213
Change the print quality setting	213
Print from a different software program	213
Check paper and quality settings	213
Check grayscale and black settings	214
Adjust color settings (Windows)	214
Check paper and the printing environment	215
Step one: Use paper that meets HP specifications	215
Step two: Check the environment	215
Visually inspect the cartridge	216
Clean the printer	217
Print and interpret the Print Quality Report	217
Clean the printhead	217
Clean the rollers	218
Try a different print driver	218
Improve copy image quality	220
Check the scanner glass for dirt and smudges	220
Calibrate the scanner	221
Check the paper settings	222
Check the paper selection options	222
Check the image-adjustment settings	222
Optimize copy quality for text or pictures	223
Edge-to-edge copying	223
Improve scan image quality	224
Check the scanner glass for dirt and smudges	224
Check the resolution settings	225
Check the image-adjustment settings	226
Optimize scan quality for text or pictures	226
Check the output-quality settings	227
Clean the pickup rollers and separation pad in the document feeder	227
Improve fax image quality	230

Check the scanner glass for dirt and smudges	230
Check the send-fax resolution settings	231
Check the image-adjustment settings	232
Optimize fax quality for text or pictures	232
Check the error-correction settings	232
Check the fit-to-page setting	233
Clean the pickup rollers and separation pad in the document feeder	233
Send to a different fax machine	235
Check the sender's fax machine	235
Solve wired network problems	236
Introduction	236
Poor physical connection	236
The computer is unable to communicate with the printer	236
The printer is using incorrect link and duplex settings for the network	237
New software programs might be causing compatibility problems	237
The computer or workstation might be set up incorrectly	237
The printer is disabled, or other network settings are incorrect	237
Solve wireless network problems	238
Introduction	238
Wireless connectivity checklist	238
The printer does not print after the wireless configuration completes	239
The printer does not print, and the computer has a third-party firewall installed	239
The wireless connection does not work after moving the wireless router or printer	239
Cannot connect more computers to the wireless printer	240
The wireless printer loses communication when connected to a VPN	240
The network does not appear in the wireless networks list	240
The wireless network is not functioning	240
Reduce interference on a wireless network	241
Solve fax problems	242
Checklist for solving fax problems	242
What type of phone line are you using?	242
Are you using a surge-protection device?	242
Are you using a phone company voice-messaging service or an answering machine? ..	242
Does your phone line have a call-waiting feature?	243
Check fax accessory status	243
General fax problems	244
The fax failed to send	244
An Out of Memory status message displays on the printer control panel	244
Print quality of a photo is poor or prints as a gray box	244
You touched the Stop button to cancel a fax, but the fax was still sent	244
No fax address book button displays	244

Not able to locate the Fax settings in HP Web Jetadmin 244
The header is appended to the top of the page when the overlay option is enabled 244
A mix of names and numbers is in the recipients box 244
A one-page fax prints as two pages 244
A document stops in the document feeder in the middle of faxing 245
The volume for sounds coming from the fax accessory is too high or too low 245

Index 247

1 Printer overview

- [Caution icons](#)
- [Printer views](#)
- [Printer specifications](#)
- [Printer hardware setup and software installation](#)

For more information:

The following information is correct at the time of publication. For current information, see www.hp.com/support/pwcolor780MFP or www.hp.com/support/pwcolor785MFP.

HP's all-inclusive help for the printer includes the following information:

- Install and configure
- Learn and use
- Solve problems
- Download software and firmware updates
- Join support forums
- Find warranty and regulatory information

Caution icons



CAUTION: Sharp edge in close proximity.



CAUTION: Keep body parts away from moving parts.



CAUTION: Hot surface.



CAUTION: Electrical shock.

Printer views

- [Printer front view](#)
- [Printer back view and interface ports](#)
- [Control-panel view](#)

Printer front view

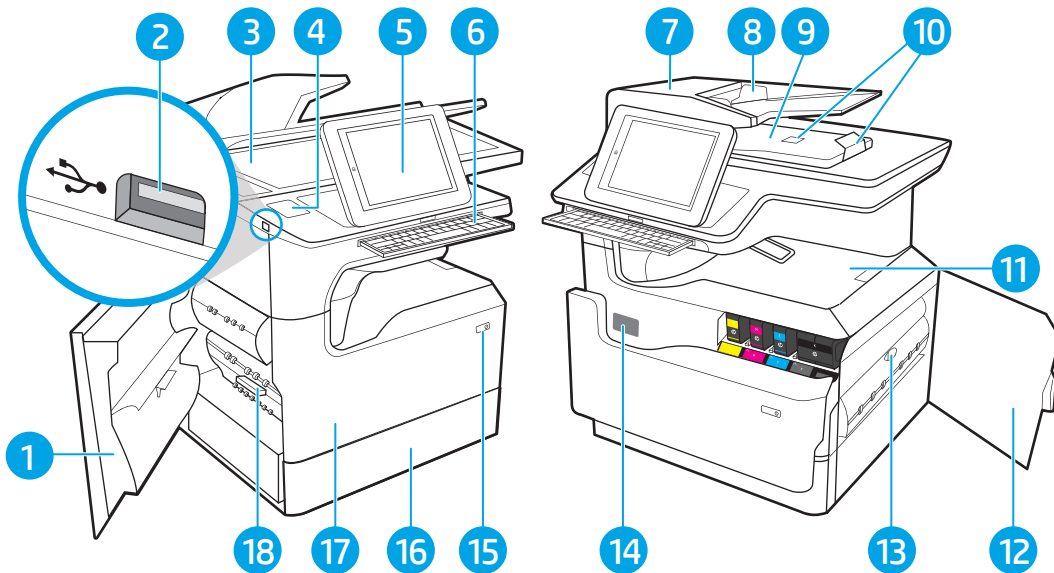

1	Left door
2	Easy-access USB printing port
3	Scanner assembly
4	Hardware integration pocket (for connecting accessories and third-party devices)
5	Control panel with color touchscreen display (tilts up for easier viewing)
6	Keyboard (785f and 785zs models only. Push the keyboard in until it clicks, and then pull the keyboard out to use it.)
	CAUTION: Close the keyboard when it is not in use.
7	Document-feeder cover (access for clearing jams)
8	Document-feeder input tray
9	Document-feeder output bin and output bin stop
10	Document-feeder output extensions
11	Output bin and output bin stop
12	Right door (access for clearing jams)
13	Duplexer
14	Serial number and product number label
15	On/Off button
16	Tray 2

17	Front door (access to the cartridges)
18	Service fluid container

Printer back view and interface ports

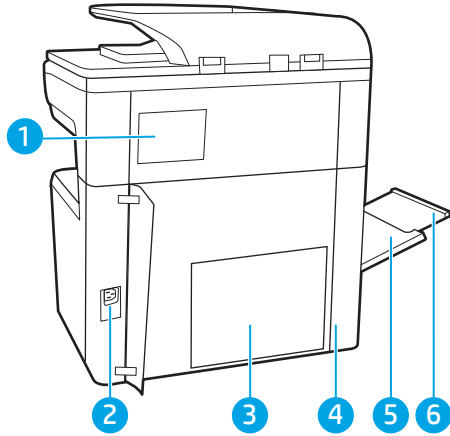

1	Stapler cover
2	Power connection
3	Formatter plate (contains the interface ports)
4	Access door to interface ports and cable lock slot
5	Tray 1 (multipurpose tray)
6	Tray 1 extension

The printer includes the following interface ports.

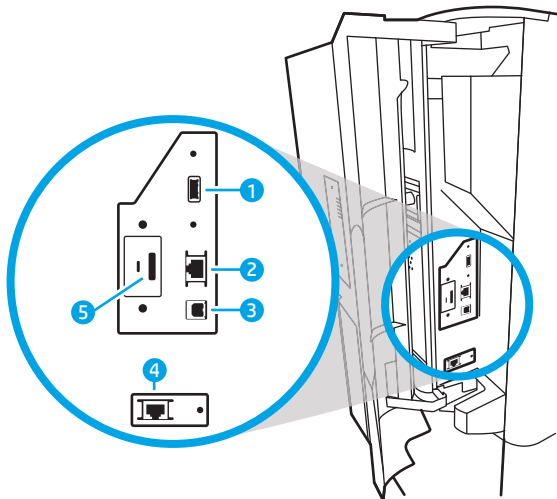

1	Host USB port for connecting external USB devices (this port might be covered)
---	--

NOTE: For easy-access USB printing, use the USB port near the control panel.

2	Local area network (LAN) Ethernet (RJ-45) network port
3	Hi-Speed USB 2.0 printing port
4	Fax port (fax models only)
5	Cable lock slot

Control-panel view



The Home screen provides access to the printer features and indicates the current status of the printer.

Return to the Home screen at any time by selecting the Home button.

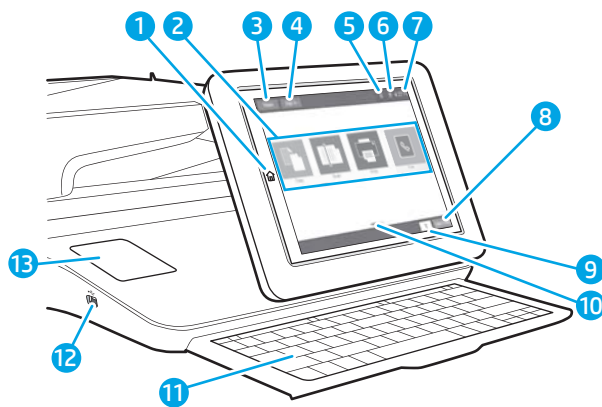
 **NOTE:** The features that appear on the Home screen can vary, depending on the printer configuration.



1	Home  button	Select the Home button to return to the Home screen.
2	Applications area	Select any of the icons to open the application. Swipe the screen sideways to access more applications. NOTE: The available applications vary by printer. The administrator can configure which applications appear and the order in which they appear.
3	Reset button	Select the Reset button to clear changes, release the printer from a paused state, reset the copy count field, display hidden errors, and restore the default settings (including the language and keyboard layout).
4	Sign In or Sign Out button	Select the Sign In button to access secured features. Select the Sign Out button to sign out of the printer. The printer restores all options to the default settings. NOTE: This button displays only if the administrator has configured the printer to require permission for access to features.

5	Information  button	Select the information button to access a screen that provides access to several types of printer information. Select the buttons at the bottom of the screen for the following information: <ul style="list-style-type: none"> • Display Language: Change the language setting for the current user session. • Sleep Mode: Place the printer into sleep mode. • Wi-Fi Direct: View information for how to connect directly to the printer using a phone, tablet, or other device with Wi-Fi. • Wireless: View or change wireless connection settings (for the z model and for the dn and f models only when an optional wireless accessory is installed). • Ethernet: View or change Ethernet connection settings. • HP Web Services: View information to connect and print to the printer using HP Web Services (ePrint). • Fax Number: View the printer fax number (fax models only).
6	Help  button	Select the Help button to open the embedded help system.
7	Current time	Displays the current time.
8	Copy button	Select the Copy button to start a copy job.
9	Copy count	The copy count indicates the number of copies that the printer is set to make.
10	Home-screen page indicator	Indicates the number of pages on the Home screen or in an application. The current page is highlighted. Swipe the screen sideways to scroll between pages.
11	Keyboard (Flow models only)	Flow models include a physical keyboard. The keys are mapped to a language in the same way the virtual keyboard on the printer touchscreen is mapped. Whenever the keyboard layout for the virtual keyboard changes, the keys on the physical keyboard are remapped to match the new settings. NOTE: In some locations, the printer comes with adhesive keyboard overlays to customize the keys for different languages.
12	Easy-access USB port	Insert a USB flash drive for printing or scanning without a computer or to update the printer firmware. NOTE: An administrator must enable this port before using for print or scan features. A firmware upgrade does not require that the port be enabled.
13	Hardware integration pocket (HIP)	For connecting accessory and third-party devices.

How to use the touchscreen control panel

Use the following actions to use the printer touchscreen control panel.

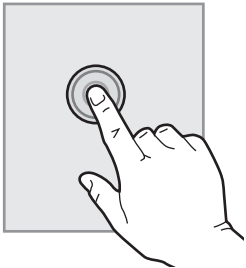
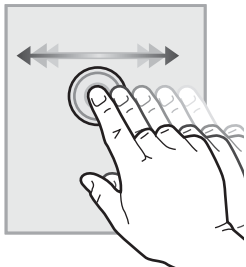
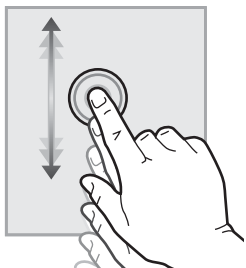
Action	Description	Example
Touch 	Touch an item on the screen to select that item or open that menu. Also, when scrolling through menus, briefly touch the screen to stop the scrolling.	Touch the Settings icon to open the Settings app.
Swipe 	Touch the screen and then move your finger horizontally to scroll the screen sideways.	Swipe until the Settings app displays.
Scroll 	Touch the screen and then move your finger vertically to scroll the screen up and down. When scrolling through menus, briefly touch the screen to stop the scrolling.	Scroll through the Settings app.

Printer specifications



IMPORTANT: The following specifications are correct at the time of publication, but they are subject to change. For current information, see www.hp.com/support/pwcolor780MFP or www.hp.com/support/pwcolor785MFP.

- [Technical specifications](#)
- [Supported operating systems](#)
- [Mobile printing solutions](#)
- [Printer dimensions](#)
- [Power consumption, electrical specifications, and acoustic emissions](#)
- [Operating environment range](#)

Technical specifications

Model name		780dn	785f	785zs
Product number		J7Z09A	J7Z11A	J7Z12A
Paper handling	Tray 1 (100-sheet capacity)	✓	✓	✓
	Tray 2 (550-sheet capacity)	✓	✓	✓
	550-sheet paper tray	Optional	Optional	Optional
	NOTE: The printer supports one optional input accessory.			
	550-sheet paper tray and stand	Optional	Optional	Optional
	3x550-sheet paper tray	Optional	Optional	✓
	4,000-sheet high-capacity input (HCI) feeder	Optional	Optional	Optional
	300-sheet inner finisher with stapler	Not supported	Not supported	✓
	Automatic duplex printing	✓	✓	✓
	Connectivity	10/100/1000 Ethernet LAN connection with IPv4 and IPv6	✓	✓
Hi-Speed USB 2.0		✓	✓	✓
Easy-access USB port for printing and scanning without a computer and upgrading the firmware		✓	✓	✓
Hardware integration pocket (HIP) for connecting accessories and third-party devices		✓	✓	✓
Wireless network connectivity		Optional	Optional	✓
HP Internal USB ports		Optional	Optional	Optional
HP Jetdirect 3000w NFC/Wireless Accessory for printing from mobile devices		Optional	Optional	Optional
HP Jetdirect 2900nw Print Server Accessory for wireless connectivity		Optional	Optional	Optional

Model name		780dn	785f	785zs
Product number		J7Z09A	J7Z11A	J7Z12A
	HP Foreign Interface Harness (FIH)	Optional	Optional	Optional
Memory	320 GB HP High-Performance Secure Hard Disk	✓	✓	✓
	Base memory: 3 GB, expandable to 4 GB by adding DIMM memory module	✓	Not supported	Not supported
	Base memory: 4.5 GB, future firmware updates may support 5.5 GB by adding DIMM memory module	Not supported	✓	✓
	HP Secure High Performance Hard Disk Drive (FIPS)	Optional	Optional	Optional
Control-panel display and input	Color touchscreen control panel	✓	✓	✓
	Retractable keyboard	Not supported	✓	✓
Print	Prints 45 pages per minute (ppm) on A4 and letter-size paper in Professional mode.	✓		
	Prints 65 ppm on A4 and letter-size paper in General Office mode.			
	Prints 55 ppm on A4 and letter-size paper in Professional mode.		✓	✓
	Prints 75 ppm on A4 and letter-size paper in General Office mode.			
	Easy-access USB printing (no computer required)	✓	✓	✓
	Store jobs in the printer memory to print later or print privately	✓	✓	✓
Fax		Optional	✓	✓
Copy and scan	Copies at speeds of up to 45 ppm on A4 and letter-size paper.	✓		
	Copies at speeds of up to 55 ppm on A4 and letter-size paper.		✓	✓
	200-page document feeder with dual-head scanning for single-pass duplex copying and scanning	✓	✓	✓
	HP EveryPage Technologies including ultrasonic multi-feed detection	Not supported	✓	✓
	Embedded optical character recognition (OCR) provides the ability to convert printed pages into text that can be edited or searched using a computer.	Not supported	✓	✓
	SMART Label feature provides paper-edge detection for automatic page cropping	Not supported	✓	✓
	Automatic page orientation for pages that have at least 100 characters of text.	Not supported	✓	✓

Model name		780dn	785f	785zs
Product number		J7Z09A	J7Z11A	J7Z12A
	Automatic tone adjustment sets contrast, brightness, and background removal for each page.	Not supported	✓	✓
Digital Send	Scan to E-mail, Scan to USB Drive, and Scan to Network Folder	✓	✓	✓
	Scan to SharePoint®	Not supported	✓	✓

Supported operating systems

Linux: For information and print drivers for Linux, go to www.hp.com/go/linuxprinting.

UNIX: For information and print drivers for UNIX®, go to www.hp.com/go/unixmodelscripts.

The following information applies to the printer-specific Windows PCL 6, HP print drivers for OS X, and to the software installer.

Windows: Download HP Easy Start from 123.hp.com/PageWide to install the HP print driver. Or go to the printer-support website for this printer: www.hp.com/support/pwcolor780MFP or www.hp.com/support/pwcolor785MFP to download the print driver or the software installer to install the HP print driver.

OS X: Mac computers are supported with this printer. Download HP Easy Start from 123.hp.com/PageWide to install the HP print driver.

1. Go to 123.hp.com/PageWide.
2. Follow the steps provided to download the printer software.

Table 1-1 Supported operating systems and print drivers

Operating system	Print driver installed (from the software on the web)	Notes
Windows® XP SP3, 32-bit	The “HP PCL.6” printer-specific print driver is installed for this operating system as part of the software installation.	Microsoft retired mainstream support for Windows XP in April 2009. HP will continue to provide best effort support for the discontinued XP operating system. Some features and page sizes in the print driver are not supported.
Windows Vista®, 32-bit	The “HP PCL.6” printer-specific print driver is installed for this operating system as part of the software installation.	Microsoft retired mainstream support for Windows Vista in April 2012. HP will continue to provide best effort support for the discontinued Vista operating system. Some features and page sizes in the print driver are not supported.
Windows 7, 32-bit and 64-bit	The “HP PCL 6” printer-specific print driver is installed for this operating system as part of the software installation.	
Windows 8, 32-bit and 64-bit	The “HP PCL 6” printer-specific print driver is installed for this operating system as part of the software installation.	Windows 8 RT support is provided through Microsoft IN OS Version 4, 32-bit driver.

Table 1-1 Supported operating systems and print drivers (continued)

Operating system	Print driver installed (from the software on the web)	Notes
Windows 8.1, 32-bit and 64-bit	The "HP PCL-6" V4 printer-specific print driver is installed for this operating system as part of the software installation.	Windows 8.1 RT support is provided through Microsoft IN OS Version 4, 32-bit driver.
Windows 10, 32-bit and 64-bit	The "HP PCL-6" V4 printer-specific print driver is installed for this operating system as part of the software installation.	
Windows Server 2008 SP2, 32-bit	The "HP PCL.6" printer-specific print driver is available for download from the printer-support website. Download the driver, and then use the Microsoft Add Printer tool to install it.	Microsoft retired mainstream support for Windows Server 2008 in January 2015. HP will continue to provide best effort support for the discontinued Server 2008 operating system. Some features and page sizes in the print driver are not supported.
Windows Server 2008 SP2, 64-bit	The "HP PCL 6" printer-specific print driver is available for download from the printer-support website. Download the driver, and then use the Microsoft Add Printer tool to install it.	Microsoft retired mainstream support for Windows Server 2008 in January 2015. HP will continue to provide best effort support for the discontinued Server 2008 operating system.
Windows Server 2008 R2, SP 1, 64-bit	The "HP PCL 6" printer-specific print driver is available for download from the printer-support website. Download the driver, and then use the Microsoft Add Printer tool to install it.	
Windows Server 2012, 64-bit	The PCL 6 printer-specific print driver is available for download from the printer-support website. Download the driver, and then use the Microsoft Add Printer tool to install it.	
Windows Server 2012 R2, 64-bit	The PCL 6 printer-specific print driver is available for download from the printer-support website. Download the driver, and then use the Microsoft Add Printer tool to install it.	
Windows Server 2016, 64-bit	The PCL 6 printer-specific print driver is available for download from the printer-support website. Download the driver, and then use the Microsoft Add Printer tool to install it.	
OS X 10.11 El Capitan, OS X 10.12 Sierra	Download HP Easy Start from 123.hp.com/PageWide , and then use it to install the print driver.	

 **NOTE:** Supported operating systems can change. For a current list of supported operating systems, go to www.hp.com/support/pwcolor780MFP or www.hp.com/support/pwcolor785MFP for HP's all-inclusive help for the printer.



 **NOTE:** For details on client and server operating systems and for HP UPD driver support for this printer, go to www.hp.com/go/upd. Under **Additional information**, click the links.

Table 1-2 Minimum system requirements

Windows	OS X
<ul style="list-style-type: none"> • Internet connection • Dedicated USB 1.1 or 2.0 connection or a network connection • 400 MB of available hard-disk space • 1 GB RAM (32-bit) or 2 GB RAM (64-bit) 	<ul style="list-style-type: none"> • Internet connection • Dedicated USB 1.1 or 2.0 connection or a network connection • 1 GB of available hard-disk space

Mobile printing solutions

HP offers multiple mobile and ePrint solutions to enable easy printing to an HP printer from a laptop, tablet, smartphone, or other mobile device. To see the full list and to determine the best choice, go to www.hp.com/go/MobilePrinting.

 **NOTE:** Update the printer firmware to ensure all mobile printing and ePrint capabilities are supported.

- Wi-Fi Direct (wireless models only, with HP Jetdirect 3000w NFC Wireless accessory installed)
- Wireless Station (wireless models only, with HP Jetdirect 3000w NFC Wireless accessory or HP 2900nw wireless print server installed)
- HP ePrint via email (Requires HP Web Services to be enabled and the printer to be registered with HP Connected)
- HP ePrint app (Available for Android and iOS)
- HP ePrint software
- Google Cloud Print
- AirPrint
- Android Printing
- Windows 10 Printing

Printer dimensions

 **NOTE:** These values are subject to change. For current information, go to www.hp.com/support/pwcolor780MFP or www.hp.com/support/pwcolor785MFP.

Table 1-3 Dimensions for base models (780dn, 785f)

	Printer fully closed	Printer fully opened
Height	682 mm (26.9 in)	995 mm (39.2 in)
Depth	628 mm (24.7 in)	1027 mm (40.4 in)
Width	604 mm (23.8 in)	1530 mm (60.2 in)
Weight (with cartridges)	68 kg (149.9 lb)	

Table 1-4 Dimensions for 785zs

	Printer fully closed	Printer fully opened
Height	1222 mm (48.1 in)	1535 mm (60.4 in)
Depth	685 mm (27 in)	1027 mm (40.4 in)
Width	604 mm (23.8 in)	1530 mm (60.2 in)
Weight (with cartridges)	122 kg (269 lb)	

Table 1-5 Dimensions for the 1x550-sheet paper feeder

	Printer fully closed	Printer fully opened
Height	117 mm (4.6 in)	117 mm (4.6 in)
Depth	520 mm (20.5 in)	685 mm (27 in)
Width	600 mm (23.6 in)	600 mm (23.6 in)
Weight (with cartridges)	9.5 kg (21 lb)	

Table 1-6 Dimensions for the 1x550-sheet paper feeder with stand

	Accessory fully closed	Accessory fully opened
Height	436 mm (17.2 in)	436 mm (17.2 in)
Depth	520 mm (20.5 in)	685 mm (27 in)
Width	600 mm (23.6 in)	600 mm (23.6 in)
Weight	28.6 kg (63 lb)	

Table 1-7 Dimensions for the 3x550-sheet paper feeder with stand

	Printer fully closed	Printer fully opened
Height	436 mm (17.2 in)	436 mm (17.2 in)
Depth	520 mm (20.5 in)	685 mm (27 in)
Width	600 mm (23.6 in)	600 mm (23.6 in)
Weight	34 kg (75 lb)	

Table 1-8 Dimensions for the 4,000-sheet HCI with stand

	Accessory fully closed	Accessory fully opened
Height	436 mm (17.2 in)	436 mm (17.2 in)
Depth	520 mm (20.5 in)	685 mm (27 in)
Width	600 mm (23.6 in)	600 mm (23.6 in)
Weight	41.3 kg (91 lb)	

Power consumption, electrical specifications, and acoustic emissions

See www.hp.com/support/pwcolor780MFP or www.hp.com/support/pwcolor785MFP for current information.

Operating environment range

Table 1-9 Operating environment range

Environment	Recommended	Allowed
Temperature	17° to 25°C (62.6° to 77°F)	15° to 30°C (59° to 86°F)
Relative humidity	30% to 70% relative humidity (RH)	10% to 80% RH
Altitude	Not applicable	0 to 3048 m (0 to 10,000 ft)

Printer hardware setup and software installation

For basic setup instructions, see the Hardware Installation Guide that came with the printer. For additional instructions, go to HP support on the Web.

Go to www.hp.com/support/pwcolor780MFP or www.hp.com/support/pwcolor785MFP for HP's all-inclusive help for the printer. Find the following support:

- Install and configure
- Learn and use
- Solve problems
- Download software and firmware updates
- Join support forums
- Find warranty and regulatory information

2 Paper trays

- [Load paper to Tray 1 \(multipurpose tray\)](#)
- [Load paper to Tray 2](#)
- [Load the 4,000-sheet high-capacity input \(HCI\) tray](#)
- [Load and print envelopes](#)
- [Load and print labels](#)
- [Configure stapling \(785zs model only\)](#)

For more information:

The following information is correct at the time of publication. For current information, see www.hp.com/support/pwcolor780MFP or www.hp.com/support/pwcolor785MFP.

HP's all-inclusive help for the printer includes the following information:

- Install and configure
- Learn and use
- Solve problems
- Download software and firmware updates
- Join support forums
- Find warranty and regulatory information

Load paper to Tray 1 (multipurpose tray)

Introduction

⚠ CAUTION: Do not extend more than one paper tray at a time. Do not use paper tray as a step. Keep hands out of paper trays when closing. All trays must be closed when moving the printer.

The following information describes how to load paper in Tray 1. The tray holds up to 100 sheets of 75 g/m² (20 lb) paper or 14 envelopes.

⚠ CAUTION: To avoid jams, never add or remove paper from Tray 1 during printing.

1. Open Tray 1.

NOTE: To print on longer paper, such as legal-size, pull out the Tray 1 extension.

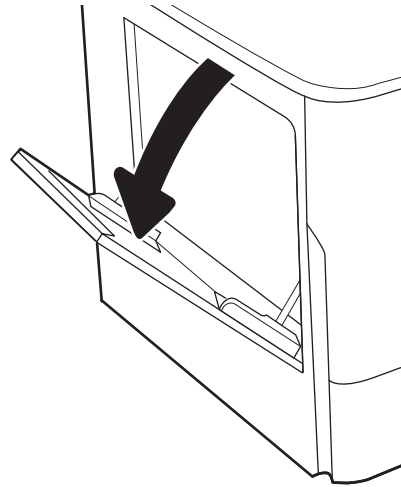

2. Adjust the paper-width guides to the size of the paper being used.

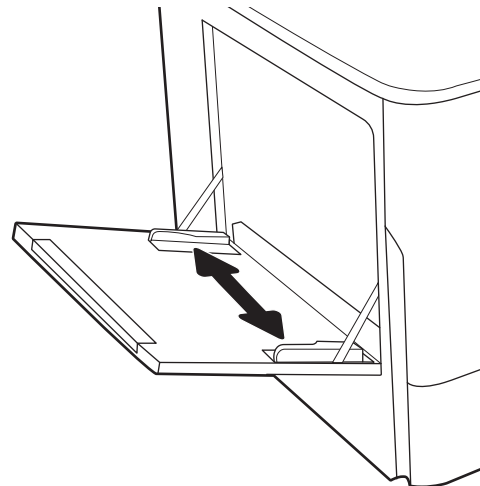

3. Load paper in the tray. For information about how to orient the paper, see [Table 2-1 Tray 1 paper orientation on page 19](#).

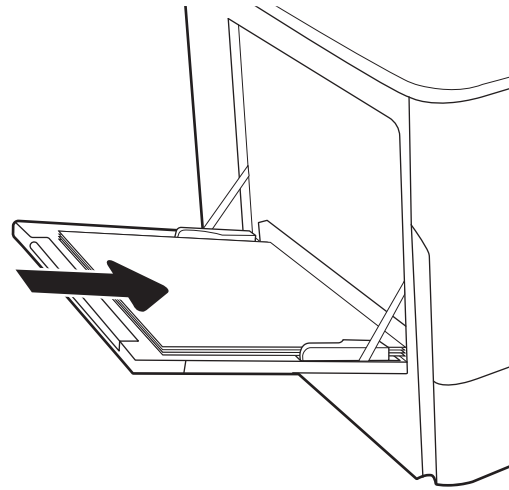

4. Adjust the width guides so that they touch the paper stack, but do not bend it.

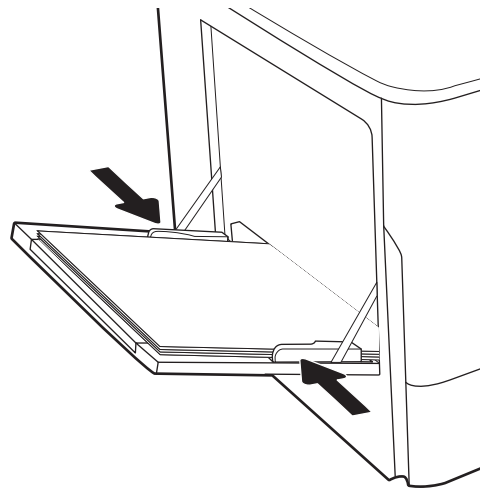

Tray 1 paper orientation

Table 2-1 Tray 1 paper orientation

Paper type	Image orientation	Duplex mode	Paper size	How to load paper
Letterhead or preprinted	Portrait	1-sided printing	12x18, 11x17, RA3, A3, 8K (273x394 mm), 8K (270x390 mm), 8K (260x368 mm), B4 (JIS), Legal, Oficio (8.5x13), Oficio (216x340 mm), C4, SRA4, RA4, Arch A, A4, Letter, 16K (197x273 mm) 16K (195x270 mm), Executive, A5, 16K (184x260 mm), B5 (JIS), Arch A, Statement, 5x8, Double Japan Postcard (148x200 mm), B6 (JIS), 5x7, 4x6, 10x15 cm, A6, Japanese Postcard (100x148 mm)	Face-down Bottom edge leading into the printer

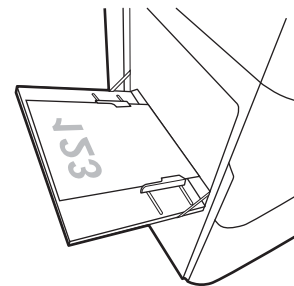

Table 2-1 Tray 1 paper orientation (continued)

Paper type	Image orientation	Duplex mode	Paper size	How to load paper
			A4, Letter, 16K (197x273 mm) 16K (195x270 mm), Executive, A5, 16K (184x260 mm), B5 (JIS), Arch A, Statement, 5x8, Double Japan Postcard (148x200 mm), 16K (195x270 mm), 16K (197x273 mm), B6 (JIS), 5x7, A6, Japanese Postcard (100x148 mm)	Face-down Left side of pre-printed image leading into the printer
		Automatic 2-sided printing or with Alternative Letterhead Mode enabled	12x18, 11x17, RA3, A3, 8K (273x394 mm), 8K (270x390 mm), 8K (260x368 mm), B4 (JIS), Legal, Oficio (8.5x13), Oficio (216x340 mm), C4, SRA4, RA4, Arch A, A4, Letter, 16K (197x273 mm) 16K (195x270 mm), Executive, A5, 16K (184x260 mm), B5 (JIS), Arch A, Statement, 5x8, Double Japan Postcard (148x200 mm), B6 (JIS), 5x7, 4x6, 10x15 cm, A6, Japanese Postcard (100x148 mm)	Face-up Top edge leading into the printer
			A4, Letter, 16K (197x273 mm), 16K (195x270 mm), Executive, A5, 16K (184x260 mm), B5 (JIS), Arch A, Statement, 5x8, Double Japan Postcard (148x200 mm), 16K (195x270 mm), 16K (197x273 mm), B6 (JIS), 5x7, A6, Japanese Postcard (100x148 mm)	Face-up Right side of pre-printed image leading into the printer

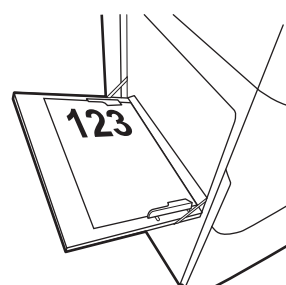
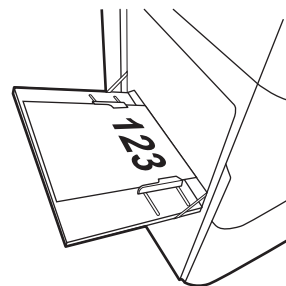
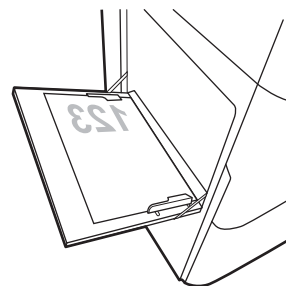

Table 2-1 Tray 1 paper orientation (continued)

Paper type	Image orientation	Duplex mode	Paper size	How to load paper
	Landscape	1-sided printing	12x18, 11x17, RA3, A3, 8K (273x394 mm), 8K (270x390 mm), 8K (260x368 mm), B4 (JIS), Legal, Oficio (8.5x13), Oficio (216x340 mm), C4, SRA4, RA4, Arch A, A4, Letter, 16K (197x273 mm), 16K (195x270 mm), Executive, A5, 16K (184x260 mm), B5 (JIS), Statement, 5x8, Double Japan Postcard (148x200 mm), B6 (JIS), 5x7 4x6, 10x15 cm, A6, Japanese Postcard (these are more narrow than 5 in and therefore must be fed short-edge-feed)	Face-down Left side of pre-printed image leading into the printer 
		Automatic 2-sided printing or with Alternative Letterhead Mode enabled	12x18, 11x17, RA3, A3, 8K (273x394 mm), 8K (270x390 mm), 8K (260x368 mm), B4 (JIS), Legal, Oficio (8.5x13), Oficio (216x340 mm), C4, SRA4, RA4, Arch A, A4, Letter, 16K (197x273 mm), 16K (195x270 mm), Executive, A5, 16K (184x260 mm), B5 (JIS), Statement, 5x8, Double Japan Postcard (148x200 mm), B6 (JIS), 5x7 4x6, 10x15 cm, A6, Japanese Postcard (these are more narrow than 5 in and therefore must be fed short-edge-feed)	Face-up Right side of the pre-printed image leading into the printer 
		1-sided printing	A4, Letter, 16K (197x273 mm) 16K (195x270 mm), Executive, A5, 16K (184x260 mm), B5 (JIS), Arch A, Statement, 5x8, Double Japan Postcard, 5x7, B6 (JIS), A6	Face-down Bottom edge leading into the printer 

Table 2-1 Tray 1 paper orientation (continued)

Paper type	Image orientation	Duplex mode	Paper size	How to load paper
		Automatic 2-sided printing or with Alternative Letterhead Mode enabled	A4, Letter, 16K (197x273 mm) 16K (195x270 mm), Executive, A5, 16K (184x260 mm), B5 (JIS), Arch A, Statement, 5x8, Double Japan Postcard, 5x7, B6 (JIS), A6	Face-up Top edge leading into the printer 
Prepunched	Portrait	1-sided printing	12x18, 11x17, RA3, A3, 8K (273x394 mm), 8K (270x390 mm), 8K (260x368 mm), B4 (JIS), Legal, Oficio (8.5x13), Oficio (216x340 mm), C4, SRA4, RA4, Arch A, A4, Letter, 16K (197x273 mm) 16K (195x270 mm), Executive, A5, 16K (184x260 mm), B5 (JIS), Arch A, Statement, A6, 5x8, Double Japan Postcard (148x200 mm), B6 (JIS), 5x7, 4x6, 10x15 cm, Japanese Postcard	Face-down Holes toward the back of the printer 
		Automatic 2-sided printing or with Alternative Letterhead Mode enabled	12x18, 11x17, RA3, A3, 8K (273x394 mm), 8K (270x390 mm), 8K (260x368 mm), B4 (JIS), Legal, Oficio (8.5x13), Oficio (216x340 mm), C4, SRA4, RA4, Arch A, A4, Letter, 16K (197x273 mm) 16K (195x270 mm), Executive, A5, 16K (184x260 mm), B5 (JIS), Arch A, Statement, A6, 5x8, Double Japan Postcard (148x200 mm), B6 (JIS), 5x7, 4x6, 10x15 cm, Japanese Postcard	Face-up Holes toward the back of the printer 

Table 2-1 Tray 1 paper orientation (continued)

Paper type	Image orientation	Duplex mode	Paper size	How to load paper
	Landscape	1-sided printing	A4, Letter, 16K (197x273 mm) 16K (195x270 mm), Executive, A5, 16K (184x260 mm), B5 (JIS), Arch A, Statement, 5x8, Double Japan Postcard, 5x7, B6 (JIS), A6	<p>Face-down</p> <p>Holes away from the printer</p> 
		Automatic 2-sided printing or with Alternative Letterhead Mode enabled	A4, Letter, 16K (197x273 mm) 16K (195x270 mm), Executive, A5, 16K (184x260 mm), B5 (JIS), Arch A, Statement, 5x8, Double Japan Postcard, 5x7, B6 (JIS), A6	<p>Face-up</p> <p>Holes towards the printer</p> 

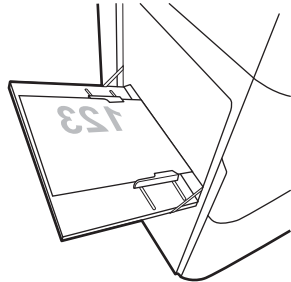
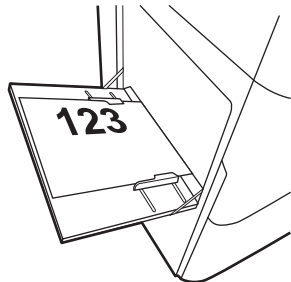
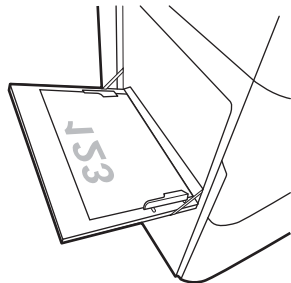
Use alternative letterhead mode

Use the [Alternative Letterhead Mode](#) feature to load letterhead or preprinted paper into the tray the same way for all jobs, whether printing to one side of the sheet of paper or to both sides. When using this mode, load paper as for automatic duplex printing.

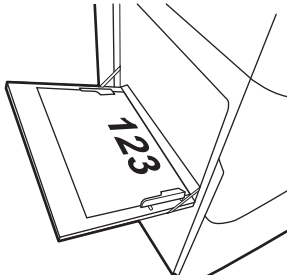
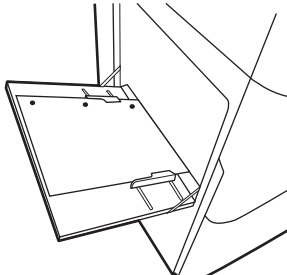
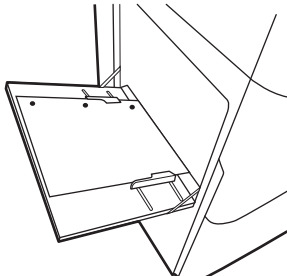
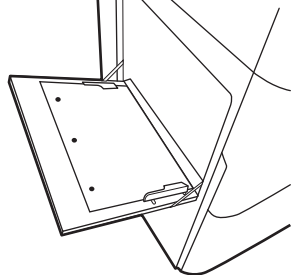
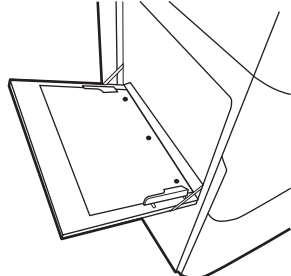
To use the feature, enable it by using the printer control-panel menus.

Enable Alternative Letterhead Mode by using the printer control-panel menus

1. From the Home screen on the printer control panel, open the [Settings](#) menu.
2. Open the following menus:
 - [Copy/Print](#) or [Print](#)
 - [Manage Trays](#)
 - [Alternative Letterhead Mode](#)
3. Select [On](#).

Load paper to Tray 2

Introduction

CAUTION: Do not extend more than one paper tray at a time. Do not use paper tray as a step. Keep hands out of paper trays when closing. All trays must be closed when moving the printer.

The following information describes how to load paper into Tray 2 and the optional 550-sheet trays. These trays hold up to 550 sheets of 75 g/m² (20 lb) paper.

NOTE: The procedure to load paper for all 550-sheet trays is the same as for Tray 2. Only Tray 2 is shown here.

1. Open the tray.

NOTE: Do not open this tray while it is in use.

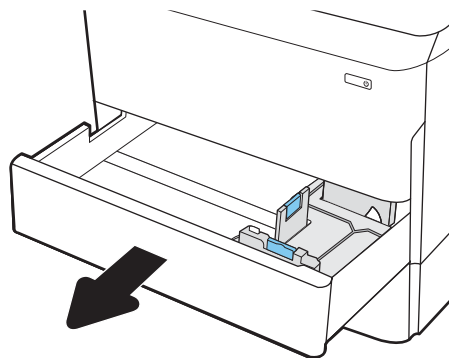

2. Adjust the paper-length and paper-width guides by squeezing the blue adjustment latches and sliding the guides to the size of the paper being used.

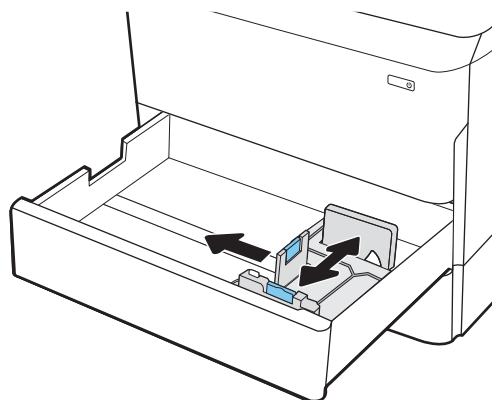

3. Load paper into the tray. Check the paper to verify that the guides touch the stack, but do not bend it. For information about how to orient the paper, see [Table 2-2 Tray 2 and the 550-sheet trays paper orientation on page 27](#).

NOTE: To prevent jams, do not overfill the tray. Be sure that the top of the stack is below the tray full indicator.

NOTE: If the tray is not adjusted correctly, an error message might appear during printing or the paper might jam.

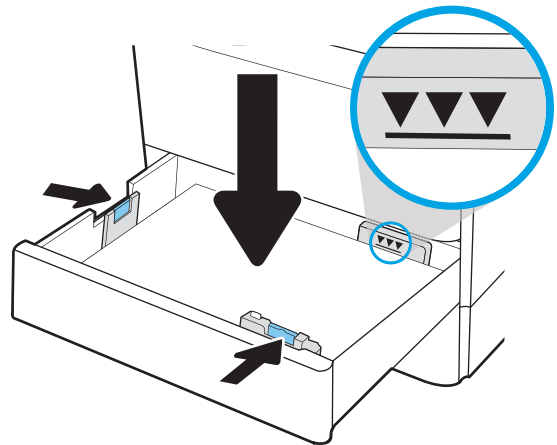

4. Close the tray.

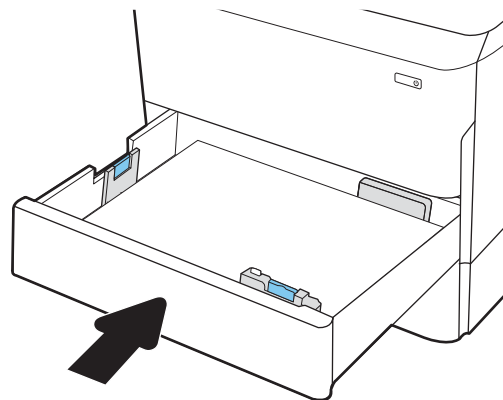

5. The tray configuration message displays on the printer control panel.
6. Select the **OK** button to accept the detected type and size, or select the **Modify** button to choose a different paper size or type.

For custom-size paper, specify the X and Y dimensions for the paper when the prompt displays on the printer control panel.

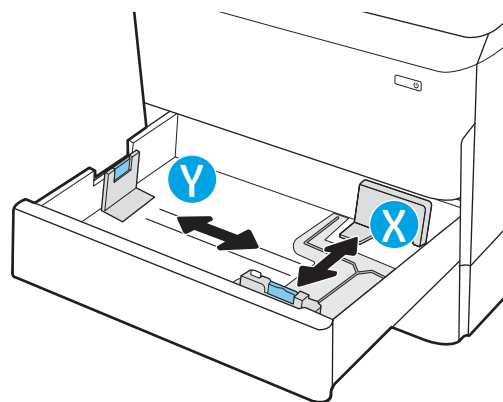

Tray 2 and the 550-sheet trays paper orientation

Table 2-2 Tray 2 and the 550-sheet trays paper orientation

Paper type	Image orientation	Duplex mode	Paper size	How to load paper
Letterhead or preprinted	Portrait	1-sided printing	11x17, A3, 8K (273x397 mm), 8K (270x390 mm), 8K (260x368 mm), B4 (JIS), Legal, Oficio (8.5x13), Oficio (216x340 mm), C4, SRA4, RA4, Arch A, A4, Letter	Face-down Top edge at the left side of the tray 
			A4, Letter, 16K (197x273 mm) 16K (195x270 mm), Executive, A5, 16K (184x260 mm), B5 (JIS)	Face-down Top edge at the back of the tray 
		Automatic 2-sided printing or with Alternative Letterhead Mode enabled	11x17, A3, 8K (273x397 mm), 8K (270x390 mm), 8K (260x368 mm), B4 (JIS), Legal, Oficio (8.5x13), Oficio (216x340 mm), C4, SRA4, RA4, Arch A, A4, Letter	Face-up Top edge at the right side of the tray 

Table 2-2 Tray 2 and the 550-sheet trays paper orientation (continued)

Paper type	Image orientation	Duplex mode	Paper size	How to load paper
			A4, Letter, 16K (197x273 mm) 16K (195x270 mm), Executive, A5, 16K (184x260 mm), B5 (JIS)	Face-up Top edge at the back of the tray
	Landscape	1-sided printing	11x17, A3, 8K (273x397 mm), 8K (270x390 mm), 8K (260x368 mm), B4 (JIS), Legal, Oficio (8.5x13), Oficio (216x340 mm), C4, SRA4, RA4, Arch A, A4, Letter	Face-down Top edge at the back of the tray
			A4, Letter, 16K (197x273 mm) 16K (195x270 mm), Executive, A5, 16K (184x260 mm), B5 (JIS)	Face-down Top edge at the left side of the tray

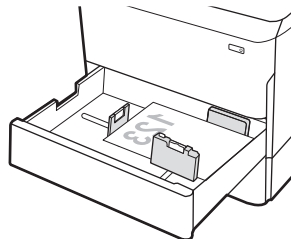
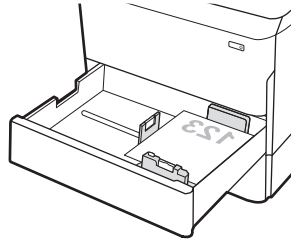
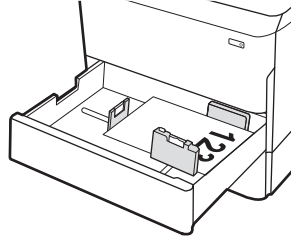
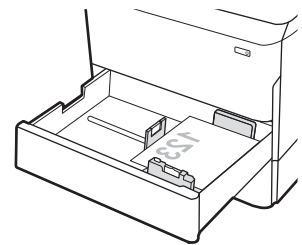
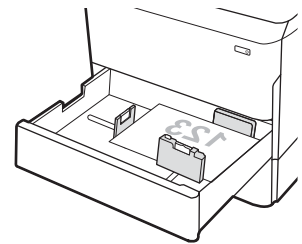
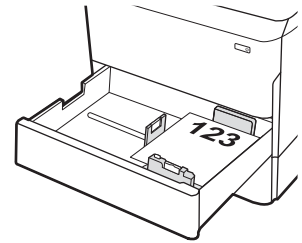

Table 2-2 Tray 2 and the 550-sheet trays paper orientation (continued)

Paper type	Image orientation	Duplex mode	Paper size	How to load paper
		Automatic 2-sided printing or with Alternative Letterhead Mode enabled	11x17, A3, 8K (273x397 mm), 8K (270x390 mm), 8K (260x368 mm), B4 (JIS), Legal, Oficio (8.5x13), Oficio (216x340 mm), C4, SRA4, RA4, Arch A, A4, Letter	<p>Face-up</p> <p>Top edge at the back of the tray</p> 
			A4, Letter, 16K (197x273 mm) 16K (195x270 mm), Executive, A5, 16K (184x260 mm), B5 (JIS)	<p>Face-up</p> <p>Top edge at the right side of the tray</p> 
Prepunched	Portrait	1-sided printing	11x17, A3, 8K (273x397 mm), 8K (270x390 mm), 8K (260x368 mm), B4 (JIS), Legal, Oficio (8.5x13), Oficio (216x340 mm), C4, SRA4, RA4, Arch A, A4, Letter	<p>Face-down</p> <p>Holes at the back of the tray</p> 

Table 2-2 Tray 2 and the 550-sheet trays paper orientation (continued)

Paper type	Image orientation	Duplex mode	Paper size	How to load paper
			A4, Letter, 16K (197x273 mm) 16K (195x270 mm), Executive, A5, 16K (184x260 mm), B5 (JIS)	Face-down Holes at the right side of the tray
		Automatic 2-sided printing or with Alternative Letterhead Mode enabled	11x17, A3, 8K (273x397 mm), 8K (270x390 mm), 8K (260x368 mm), B4 (JIS), Legal, Oficio (8.5x13), Oficio (216x340 mm), C4, SRA4, RA4, Arch A, A4, Letter	Face-up Holes at the back of the tray
			A4, Letter, 16K (197x273 mm) 16K (195x270 mm), Executive, A5, 16K (184x260 mm), B5 (JIS)	Face-up Holes at the left side of the tray, with the top of the form at the rear of the printer

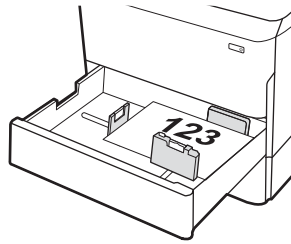
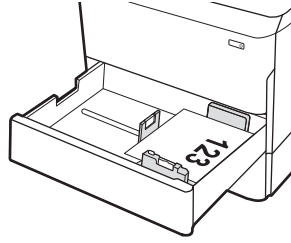
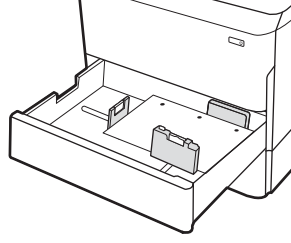
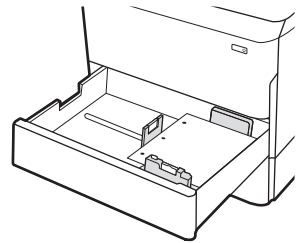
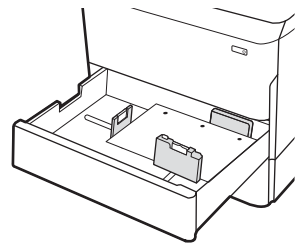
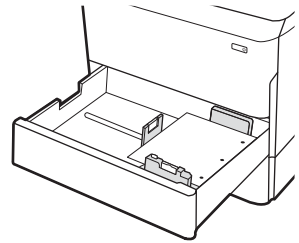

Use alternative letterhead mode

Use the [Alternative Letterhead Mode](#) feature to load letterhead or preprinted paper into the tray the same way for all jobs, whether printing to one side of the sheet of paper or to both sides. When using this mode, load paper as for automatic duplex printing.

To use the feature, enable it by using the printer control-panel menus.

Enable Alternative Letterhead Mode by using the printer control-panel menus

1. From the Home screen on the printer control panel, open the [Settings](#) menu.
2. Open the following menus:
 - [Copy/Print or Print](#)
 - [Manage Trays](#)
 - [Alternative Letterhead Mode](#)
3. Select [On](#).

Load the 4,000-sheet high-capacity input (HCI) tray

Introduction

⚠ CAUTION: Do not extend more than one paper tray at a time. Do not use paper tray as a step. Keep hands out of paper trays when closing. All trays must be closed when moving the printer.

The following information describes how to load paper in the high-capacity input tray, which is available as an accessory for all models. The two trays hold up to 4,000 sheets of 75 g/m² (20 lb) paper.

1. Open the tray.

NOTE: Do not open this tray while it is in use.

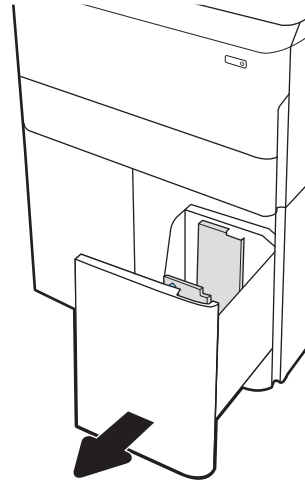

2. Adjust the paper-size guide to the correct position for the paper.

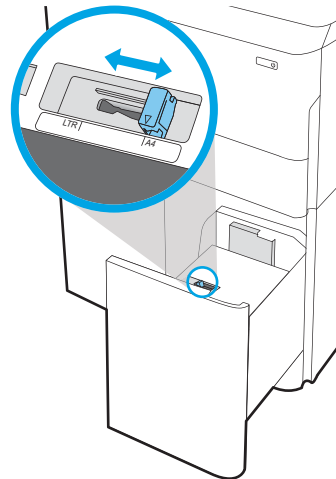

3. Load paper into the tray. Check the paper to verify the guides lightly touch the stack, but do not bend it.

NOTE: To prevent jams, do not overfill the tray. Be sure that the top of the stack is below the tray full indicator.

NOTE: If the tray is not adjusted correctly, an error message might appear during printing or the paper might jam.

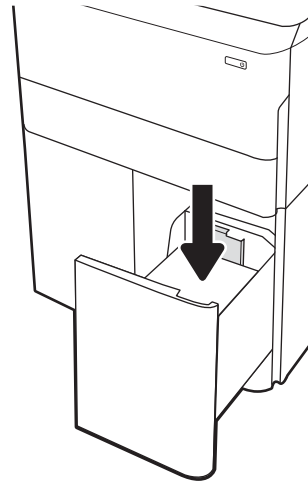

4. Close the tray.

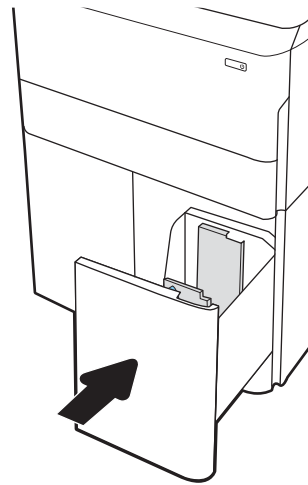

5. The tray configuration message displays on the printer control panel.
6. Select the **OK** button to accept the detected type and size, or select the **Modify** button to choose a different paper size or type.

HCI paper orientation

Table 2-3 HCI paper orientation

Paper type	Image orientation	Duplex mode	Paper size	How to load paper
Letterhead or preprinted	Portrait	1-sided printing	A4, Letter	Face-down Top edge at the back of the tray
		Automatic 2-sided printing or with Alternative Letterhead Mode enabled	A4, Letter	Face-up Top edge at the back of the tray
	Landscape	1-sided printing	A4, Letter	Face-down Top edge at the left side of the tray

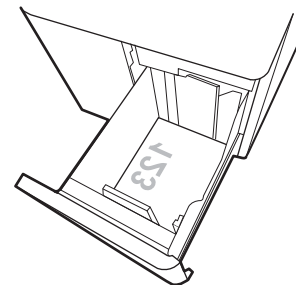
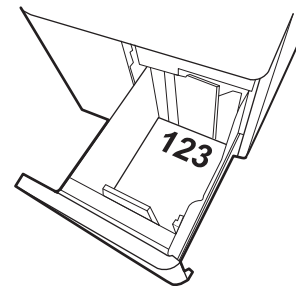
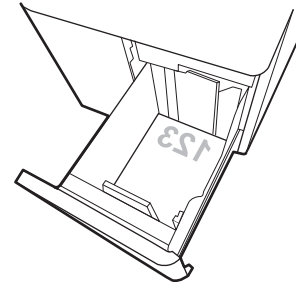
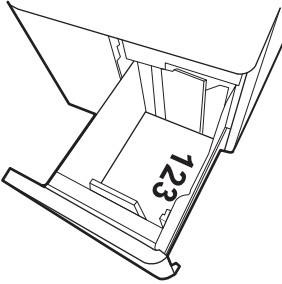
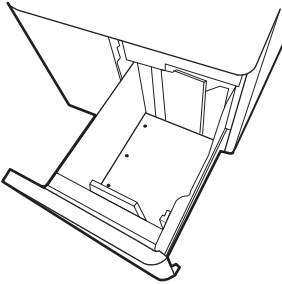
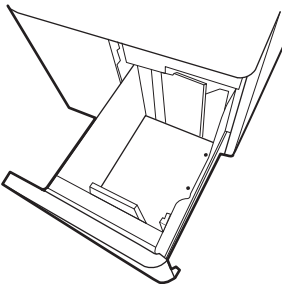

Table 2-3 HCI paper orientation (continued)

Paper type	Image orientation	Duplex mode	Paper size	How to load paper
		Automatic 2-sided printing or with Alternative Letterhead Mode enabled	A4, Letter	Face-up Top edge at the right side of the tray 
Prepunched	Landscape	1-sided printing	A4, Letter	Face-down Holes at the left side of the tray 
		Automatic 2-sided printing or with Alternative Letterhead Mode enabled	A4, Letter	Face-up Holes at the right side of the tray, with the top of the form to the right side 

Use alternative letterhead mode

Use the [Alternative Letterhead Mode](#) feature to load letterhead or preprinted paper into the tray the same way for all jobs, whether printing to one side of the sheet of paper or to both sides. When using this mode, load paper as for automatic duplex printing.

To use the feature, enable it by using the printer control-panel menus.

Enable Alternative Letterhead Mode by using the printer control-panel menus

1. From the Home screen on the printer control panel, open the [Settings](#) menu.
2. Open the following menus:
 - [Copy/Print or Print](#)
 - [Manage Trays](#)
 - [Alternative Letterhead Mode](#)
3. Select [On](#).

Load and print envelopes

Introduction

The following information describes how to print and load envelopes. Use only Tray 1 to print on envelopes. Tray 1 holds up to 14 envelopes, depending on envelope design and environmental conditions.

To print envelopes using the manual feed option, follow these steps to select the correct settings in the print driver, and then load the envelopes into the tray after sending the print job to the printer.

Print envelopes

1. From the software program, select the **Print** option.
2. Select the printer from the list of printers, and then click or tap the **Properties** or **Preferences** button to open the print driver.

 **NOTE:** The name of the button varies for different software programs.

 **NOTE:** To access print features from a Windows 8 or 8.1 Start screen app, select **Devices**, select **Print**, and then select the printer. For Windows 10, select **Print**, which can vary depending on the application. For Windows 8, 8.1, and 10, these applications will have a different layout with different features than what is described below for desktop applications. For the HP PCL-6 V4 driver, the HP AiO Printer Remote application will download additional driver features when **More settings** is selected.

3. Click or tap the **Paper/Quality** tab.
4. In the **Paper size** drop-down list, select the correct size for the envelopes.
5. In the **Paper type** drop-down list, select **Envelope**.
6. In the **Paper source** drop-down list, select **Manual feed**.
7. Click the **OK** button to close the **Document Properties** dialog box.
8. In the **Print** dialog box, click the **OK** button to print the job.

Envelope orientation

 **NOTE:** The printer does not support duplex printing on envelopes.

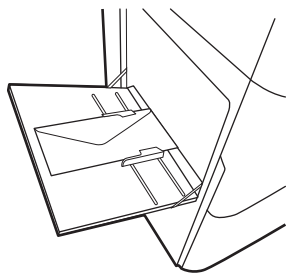
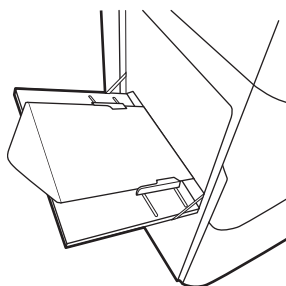
Tray	Envelope size	How to load
Tray 1	Envelope #9, Envelope #10, Envelope Monarch, Envelope DL, Envelope B5, Envelope C5 (wallet), Envelope C6	<p data-bbox="1053 231 1157 262">Face-down</p> <p data-bbox="1053 283 1396 315">Top edge toward the back of the printer</p> 
	Envelope B5, Japanese Envelope Chou #3, Envelope C5 (pocket)	<p data-bbox="1053 619 1157 651">Face-down</p> <p data-bbox="1053 672 1412 724">Bottom edge leading into the printer; top flap open</p> 

Load and print labels

Introduction

The following information describes how to print and load labels.

To print labels using the manual feed option, follow these steps to select the correct settings in the print driver, and then load the labels into the tray after sending the print job to the printer. When using manual feed, the printer waits to print the job until it detects that the tray has been opened.

Manually feed labels

1. From the software program, select the **Print** option.
2. Select the printer from the list of printers, and then click or tap the **Properties** or **Preferences** button to open the print driver.



NOTE: The name of the button varies for different software programs.



NOTE: To access print features from a Windows 8 or 8.1 Start screen app, select **Devices**, select **Print**, and then select the printer. For Windows 10, select **Print**, which can vary depending on the application. For Windows 8, 8.1, and 10, these applications will have a different layout with different features than what is described below for desktop applications. For the HP PCL-6 V4 driver, the HP AiO Printer Remote application will download additional driver features when **More settings** is selected.

3. Click the **Paper/Quality** tab.
4. In the **Paper size** drop-down list, select the correct size for the sheets of labels.
5. In the **Paper type** drop-down list, select **Labels**.
6. In the **Paper source** drop-down list, select **Manual feed**.
7. Click the **OK** button to close the **Document Properties** dialog box.
8. In the **Print** dialog box, click the **Print** button to print the job.

Label orientation

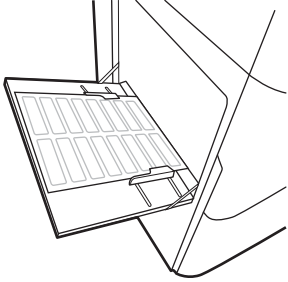
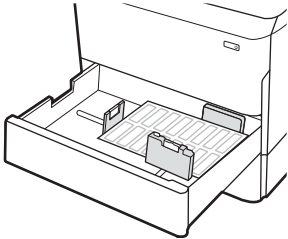
Tray	How to load labels
Tray 1	<p data-bbox="453 289 552 315">Face-down</p> <p data-bbox="453 340 767 365">Bottom edge leading into the printer</p> 
550-sheet trays	<p data-bbox="453 701 552 726">Face-down</p> <p data-bbox="453 751 756 777">Top edge at the left side of the tray</p> 

Configure stapling (785zs model only)

The following information describes how to load staples and configure the options for the stapling accessory.

The stapling accessory can staple documents in the upper left or upper right corners, and it can stack up to 250 sheets of paper in the finisher.

- [Configure the default staple location](#)
- [Configure the operation mode](#)

Configure the default staple location

1. From the Home screen on the printer control panel, swipe until the **Settings** menu displays. Select the **Settings** icon to open the menu.
2. Open the following menus:
 - **Copy/Print**
 - **Default Print Options**
 - **Staple**
3. Select a staple location from the list of options. The following options are available:
 - **None:** No staples
 - **Top left or right:** If the document has portrait orientation, the staple is in the top left corner of the short edge of the paper. If the document has landscape orientation, the staple is in the top right corner of the long edge of the paper.
 - **Top left:** The staple is in the top left corner of the short edge of the paper.
 - **Top right:** The staple is in the top right corner of the long edge of the paper.

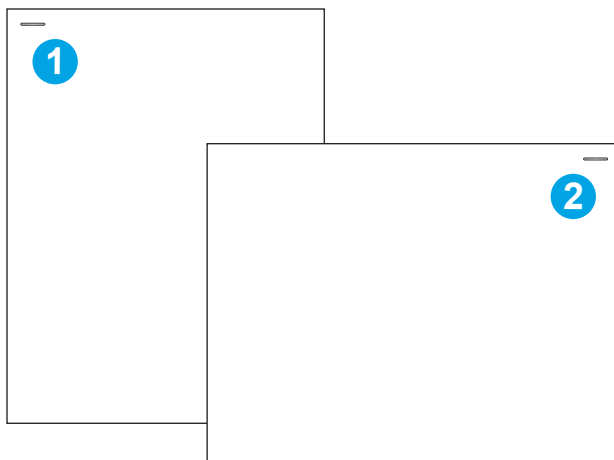

1	Top left corner of the short edge of the paper
2	Top right corner of the long edge of the paper

Configure the operation mode

Use this procedure to configure how the printer sorts jobs into the output bins.

1. From the Home screen on the printer control panel, swipe until the **Settings** menu displays. Select the **Settings** icon to open the menu.
2. Open the following menus:
 - **Manage Stapler/Stacker**
 - **Operation Mode**
3. Select a mode from the list of options. The following options are available:
 - **Mailbox**: The printer places jobs in different bins according to the person who sent them.
 - **Stacker**: The printer stacks jobs in the bins from bottom to top.
 - **Function Separator**: The printer places jobs in different bins according to printer function such as print jobs, copy jobs, or fax jobs.

To configure the HP print driver for the selected operation mode, complete the following steps:

 **NOTE:** Changing the operation mode causes the printer to restart.

Windows XP and Vista (Server 2008) HP PCL.6 drivers do not support output devices.

Windows® 7

1. Make sure the printer is turned on and connected to the computer or a network.
2. Open the Windows® Start menu, and then click **Devices and Printers**.
3. Right-click the name of the printer, and then select **Printer Properties**.
4. Click the **Device Settings** tab.
5. Select **Update Now**. Or, in the drop-down menu next to **Automatic Configuration**, select **Update Now**.

Windows® 8.0, 8.1, and 10

1. Right-click on the bottom-left corner of the screen.
2. Select **Control Panel**. Under **Hardware and Sound**, select **View devices and printers**.
3. Right-click the name of the printer, and then select **Printer Properties**.
4. Click the **Device Settings** tab.
5. Select **Update Now**. Or, in the drop-down menu next to **Automatic Configuration**, select **Update Now**.

 **NOTE:** Newer HP PCL-6 V4 drivers do not support **Update Now**. For these drivers, stop and restart the print spooler. Click the **Start** button (or open a search box), in the search box type "services.msc", and then press the **Enter** key. Right-click **Print Spooler** in the list of services, select **Stop**, and then right-click and select **Start**.

OS X

1. From the Apple menu, click **System Preferences**.
2. Select **Print & Scan** (or **Printers & Scanners**).
3. Select the printer, and then select **Options & Supplies**. Select **Options**.
4. Manually configure the **Accessory Output Mode**.

3 Supplies, accessories, and parts

- [Order supplies, accessories, and parts](#)
- [Replace the cartridges](#)
- [Replace the service fluid container](#)
- [Replace the staple cartridge \(785zs model only\)](#)

For more information:

The following information is correct at the time of publication. For current information, see www.hp.com/support/pwcolor780MFP or www.hp.com/support/pwcolor785MFP.

HP's all-inclusive help for the printer includes the following information:

- Install and configure
- Learn and use
- Solve problems
- Download software and firmware updates
- Join support forums
- Find warranty and regulatory information

Order supplies, accessories, and parts

Ordering

Order supplies and paper	www.hp.com/go/suresupply
Order genuine HP parts or accessories	www.hp.com/buy/parts
Order through service or support providers	Contact an HP-authorized service or support provider.
Order using the HP Embedded Web Server (EWS)	To access, in a supported web browser on your computer, enter the printer IP address or host name in the address/URL field. The EWS contains a link to the HP SureSupply website, which provides options for purchasing Original HP supplies.

Supplies and accessories

Item	Description	Cartridge number	Part number
Supplies			
HP 982X High Yield Black Original PageWide Cartridge	High-capacity replacement black cartridge	982X	T0B30A
HP 982X High Yield Cyan Original PageWide Cartridge	High-capacity replacement cyan cartridge	982X	T0B27A
HP 982X High Yield Magenta Original PageWide Cartridge	High-capacity replacement magenta cartridge	982X	T0B28A
HP 982X High Yield Yellow Original PageWide Cartridge	High-capacity replacement yellow cartridge	982X	T0B29A
HP 982A Black Original PageWide Cartridge	Standard-capacity replacement black cartridge	982A	T0B26A
HP 982A Cyan Original PageWide Cartridge	Standard-capacity replacement cyan cartridge	982A	T0B23A
HP 982A Magenta Original PageWide Cartridge	Standard-capacity replacement magenta cartridge	982A	T0B24A
HP 982A Yellow Original PageWide Cartridge	Standard-capacity replacement yellow cartridge	982A	T0B25A
Accessories			
1 GB DDR3 Memory DIMM	Memory upgrade kit	Not applicable	E5K48-67902
HP PageWide 550-sheet Paper Tray	Optional input tray	Not applicable	A7W99A
HP PageWide 550-sheet Paper Tray and Stand	Optional input tray and cabinet stand	Not applicable	W1B50A
HP Page Wide 3x550-sheet Paper Tray and Stand	Optional input trays and stand	Not applicable	W1B51A
HP Page Wide 4000-sheet HCl Paper Tray and Stand	Optional high-capacity input feeder and stand	Not applicable	W1B52A
HP Foreign Interface Harness	Optional port for connecting third-party devices	Not applicable	B5L31-67902

Item	Description	Cartridge number	Part number
Two-Internal USB Ports for Solutions, AA Board	Optional USB ports for connecting third-party devices	Not applicable	B5L28-67902
HP Secure High Performance Hard Disk Drive FIPS Drive	Secure hard drive	Not applicable	B5L29-67903
HP Jetdirect Wireless Print Server with NFC	Wireless accessory for "touch" printing from mobile devices	Not applicable	J8031-61001
HP Jetdirect USB Wireless Print Server	USB wireless print server accessory	Not applicable	J8030-61001

Maintenance/long-life consumables (LLC)

Maintenance/LLC Kit	Part number	Estimated life ¹
HP PageWide ADF Maintenance Kit	J8J95A	150,000 pages
HP PageWide Service Fluid Container	W1B44A	150,000 pages
HP PageWide Printhead Wiper Kit	W1B43A	150,000 pages
HP PageWide Roller Kit	W1B45A	150,000 pages
HP Staple Cartridge Kit	W1B48A	5,000 staples

¹ HP Maintenance/Long Life Consumables (LLC) life specifications are estimations based on the LLC life test conditions listed below. Actual individual life/yield during normal use varies depending on usage, environment, paper and other factors. Estimated life is not an implied guarantee or warrantable.

The LLC life test conditions

- Print coverage: 5% evenly distributed across the page
- Environment: 17° to 25°C (62.6° to 77°F); 30%-70% relative humidity (RH)
- Media size: Letter/A4
- Media weight: 75 g/m² (20 lb) plain media
- Job size: 4 pages
- Short edge feed (A3) (i.e., Legal size media)

Factors that can reduce life from the conditions above:

- Media narrower than Letter/A4 widths (short edge feeds equal more mechanism activity per page)
- Paper heavier than 75 g/m² (20 lb) (heavier media creates higher stress on printer components)
- Print jobs smaller than 4 image (smaller jobs mean more mechanism activity per page)

Customer self-repair parts

The following parts are available for the printer.

- Parts listed as **Mandatory** self-replacement are to be installed by customers, unless you are willing to pay HP service personnel to perform the repair. For these parts, on-site or return-to-depot support is not provided under the HP product warranty.
- Parts listed as **Optional** self-replacement can be installed by HP service personnel at your request for no additional charge during the product warranty period.

Item	Description	Self-replacement options	Part number
Service Fluid Container Kit	Replacement service fluid unit	Mandatory	A7W93-67081
Printhead Wiper Kit	Replacement printhead wiper	Mandatory	A7W93-67080
Tray 2-5 Roller Kit	Replacement rollers for trays 2-5	Mandatory	A7W93-67082
Tray 1 Roller Kit	Replacement rollers for tray 1	Optional	A7W93-67039
ADF Roller Replacement Kit	Replacement feed rollers for the document feeder	Mandatory	5851-7202
Staple Cartridge Kit	Replacement staple cartridge	Mandatory	J7Z09-67933
Tray 2-5 Assembly Kit	Replacement Tray 2-5	Mandatory	A7X02-67006
HCI Left Tray	Replacement left tray for HCI	Mandatory	A7W97-67008
HCI Right Tray	Replacement right tray for HCI	Mandatory	A7W97-67012
Optional 550-sheet Table Top Feeder	Replacement Tray 3 feeder	Mandatory	A7W99-67001
1x550-sheet Paper Feeder and Stand	Replacement Tray 3 feeder and stand	Mandatory	W1B50-67001
1x550 Feeder Storage Bin	Replacement for 1x550 feeder storage bin	Mandatory	A7W95-67024
3x500-sheet Paper Feeder and Stand	Replacement 3x500-sheet paper feeder and stand	Mandatory	W1B51-67001
HP Page Wide 4000-sheet HCI Paper Tray and Stand	Optional high-capacity input feeder and stand	Mandatory	W1B52-67001
HP Secure High Performance Hard Disk Drive FIPS Drive	Replacement secure hard drive	Mandatory	B5L29-67903
320 GB HDD kit	Replacement hard drive	Mandatory	5851-6712
Scanner White Backing	Replacement white plastic backing for the scanner	Mandatory	J7Z09-67926
Retention-Clip Assembly	Replacement retention clips that are behind the scanner white backing	Mandatory	J7Z09-67927
Control Panel Assembly Kit	Replacement touchscreen control panel	Mandatory	J7Z09-67928
HIP 2 Cover	Replacement HIP 2 cover	Mandatory	J7Z09-67901
USB Cover, Center CP (inner finisher models only)	Replacement easy access USB cover	Mandatory	J7Z09-67902
USB Cover, Left CP	Replacement easy access USB cover	Mandatory	J7Z09-67903
Keyboard Overlay Kit	Replacement keyboard overlay (Flow models)	Mandatory	5851-6019
French, Italian, Russian, German, Spanish, Ukrainian			

Item	Description	Self-replacement options	Part number
Keyboard Overlay Kit Canadian French, Latin American Spanish, U.S. Spanish	Replacement keyboard overlay (Flow models)	Mandatory	5851-6020
Keyboard Overlay Kit Swiss French, Swiss German, Danish	Replacement keyboard overlay (Flow models)	Mandatory	5851-6021
Keyboard Overlay Kit Simplified Chinese, Traditional Chinese	Replacement keyboard overlay (Flow models)	Mandatory	5851-6022
Keyboard Overlay Kit Spanish, Portuguese	Replacement keyboard overlay (Flow models)	Mandatory	5851-6023
Keyboard Overlay Kit Japanese (KG and KT)	Replacement keyboard overlay (Flow models)	Mandatory	5851-6024
Overlay-Keyboard Chinese	Replacement keyboard overlay (Flow models)	Mandatory	A7W12-67901
Overlay-Keyboard Sweden	Replacement keyboard overlay (Flow models)	Mandatory	A7W14-67901
HP Jetdirect 2900nw Print Server	Replacement USB wireless print server accessory	Mandatory	J8031-61001
HP Jetdirect 3000w NFC/Wireless Accessory	Replacement Wireless Direct Print accessory for "touch" printing from mobile devices	Mandatory	J8030-61001
HP 1 GB DDR3x32 144- Pin 800 MHz SODIMM	Replacement memory DIMM	Mandatory	E5K48-67902
HP LaserJet MFP Analog Fax Accessory 500	Replacement fax board	Mandatory	B5L53-67901
HP Foreign Interface Harness	Replacement HP Foreign Interface Harness	Mandatory	B5L31-67902
Two-Internal USB Ports for Solutions, AA Board	Optional USB ports for connecting third-party devices	Mandatory	B5L28-67902
Formatter access cover	Replacement for formatter cover	Mandatory	J7Z09-67935
Formatter access cover, lock access	Lock cover plate	Mandatory	J7Z09-67936
Formatter cage cover	Formatter cage cover	Mandatory	J7Z09-67937
Dashboard Cover for Center CP (inner finisher models only)	Replacement for CP dashboard cover with center CP	Mandatory	J7Z09-67904
Dashboard Cover for Left CP	Replacement for CP dashboard cover with left CP	Mandatory	J7Z09-67905

Replace the cartridges

Introduction

The following information provides details about the cartridges for the printer, and it includes instructions to replace them.

Cartridge information

This printer indicates when the cartridge level is low, very low, or depleted.

The printer uses four colors and has a different cartridge for each color: yellow (Y), cyan (C), magenta (M), and black (K).

Do not remove the cartridge from its package until you are ready to use it.

CAUTION: To prevent damage to the cartridge do not touch the gold-colored metal contacts of the cartridge.

The following illustration shows the cartridge components.



1 Metal contact. Do not touch the gold-colored metal contacts of the cartridge. Fingerprints on the contacts can damage the cartridge.

To purchase cartridges or check cartridge compatibility for the printer, go to HP SureSupply at www.hp.com/go/suresupply. Scroll to the bottom of the page and verify that the country/region is correct.

Table 3-1 Cartridge information

Item	Description	Cartridge number	Part number
HP 982X High Yield Black Original PageWide Cartridge	High-capacity replacement black cartridge	982X	T0B30A
HP 982X High Yield Cyan Original PageWide Cartridge	High-capacity replacement cyan cartridge	982X	T0B27A
HP 982X High Yield Magenta Original PageWide Cartridge	High-capacity replacement magenta cartridge	982X	T0B28A
HP 982X High Yield Yellow Original PageWide Cartridge	High-capacity replacement yellow cartridge	982X	T0B29A

Table 3-1 Cartridge information (continued)

Item	Description	Cartridge number	Part number
HP 982A Black Original PageWide Cartridge	Standard-capacity replacement black cartridge	982A	T0B26A
HP 982A Cyan Original PageWide Cartridge	Standard-capacity replacement cyan cartridge	982A	T0B23A
HP 982A Magenta Original PageWide Cartridge	Standard-capacity replacement magenta cartridge	982A	T0B24A
HP 982A Yellow Original PageWide Cartridge	Standard-capacity replacement yellow cartridge	982A	T0B25A

 **NOTE:** High-yield cartridges contain more pigment than standard cartridges for increased page yield. For more information, go to www.hp.com/go/learnaboutsupplies.

 **NOTE:** Information about recycling used cartridges is in the cartridge box.

Remove and replace the cartridges

1. Open the cartridge door.

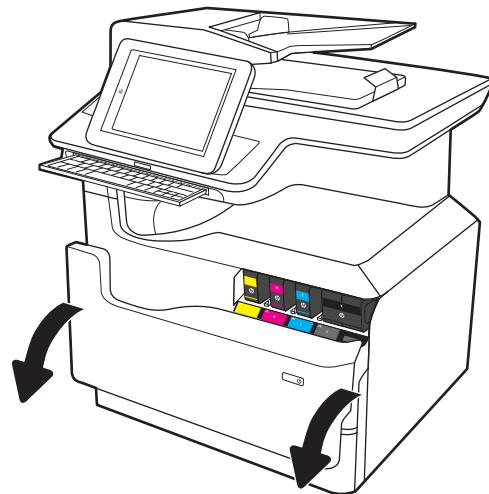

2. Push the old cartridge inward to unlock it.

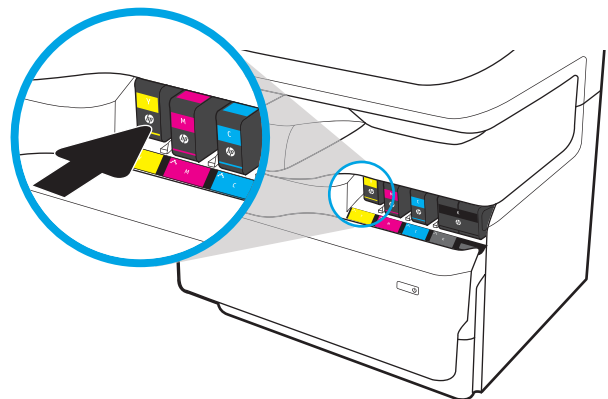

3. Grasp the edge of the old cartridge and then pull the cartridge straight out to remove it.

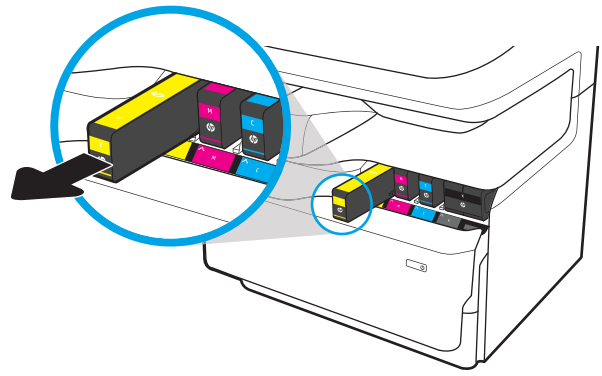

4. Remove the new cartridge from the packaging.

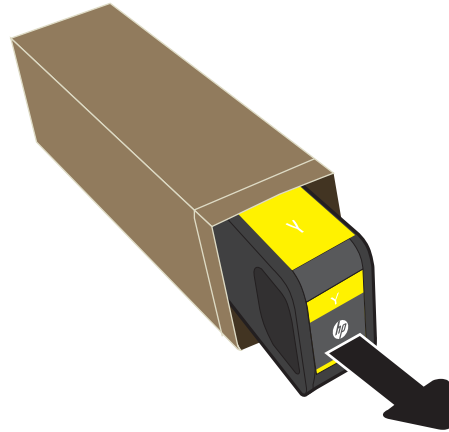

5. Do not touch the gold-colored metal contacts of the cartridge. Fingerprints on the contacts can damage the cartridge.



6. Insert the new cartridge into the product. Make sure the cartridge is firmly in place.

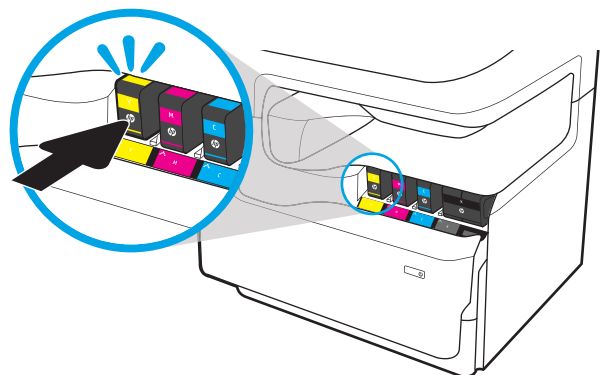

7. Close the cartridge door.

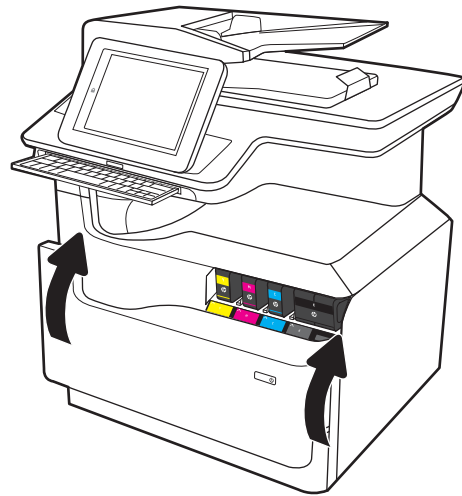

8. Pack the used cartridge in the box that the new cartridge came in. See the enclosed recycling guide for information about recycling.

HP helps you recycle your Original HP cartridges—it's easy and free with the HP Planet Partners program, available in more than 50 countries/regions around the world¹⁾.

To find information about how to recycle used HP cartridges, please go to www.hp.com/recycle.

¹⁾ Program availability varies. For more information, visit www.hp.com/recycle.

Replace the service fluid container

- [Introduction](#)
- [Remove and replace the service fluid container](#)

Introduction

The following information provides details about the service fluid container for the printer, and it includes instructions to replace it.

The printer indicates when the service fluid container is nearly full and when it is completely full. When it is completely full, printing stops until the service fluid container is replaced.

To purchase a service fluid container (part number W1B44A), go to the HP Parts Store at www.hp.com/buy/parts.

 **NOTE:** The service fluid container is designed for a single use. Do not attempt to empty the service fluid container and reuse it. Doing so could lead to pigment being spilled inside the printer, which could result in reduced print quality. After use, return the service fluid container to HP's Planet Partners program for recycling.

Remove and replace the service fluid container

1. Open the left door.

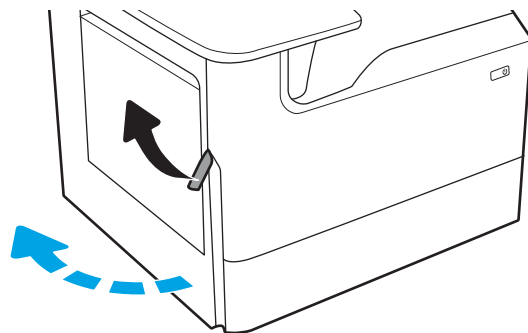

2. Pull the service fluid container away from the printer.

CAUTION: When pulling out the service fluid container, avoid making direct contact with the black cylinder to prevent pigment smear on skin or clothes.

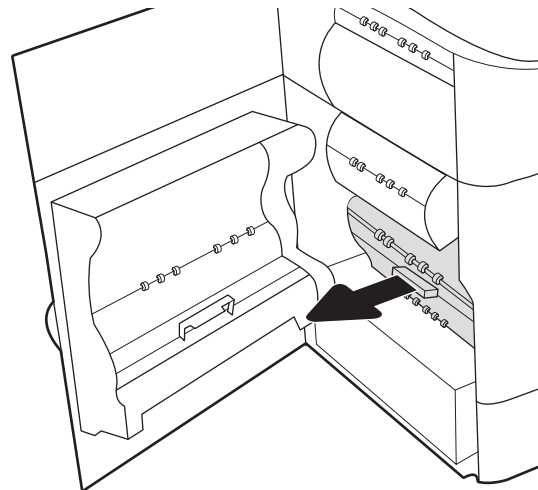

3. On the left side of the service fluid container, release the latch that holds the unit in the alignment track, and then remove the left side of the unit.

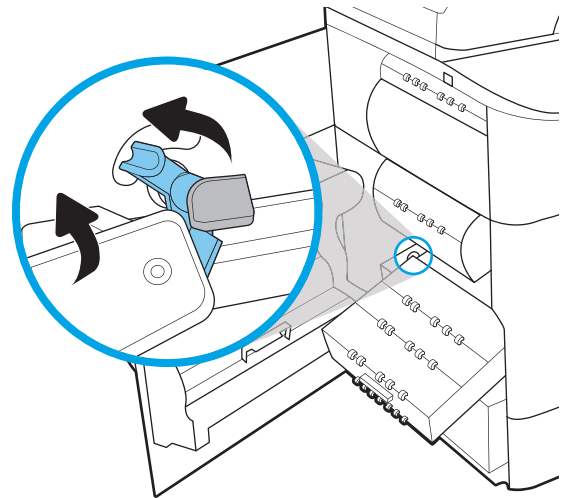

4. Remove the right side from the alignment track, and then remove the unit from the printer. Set the unit aside, upright, on a piece of paper to prevent spills.

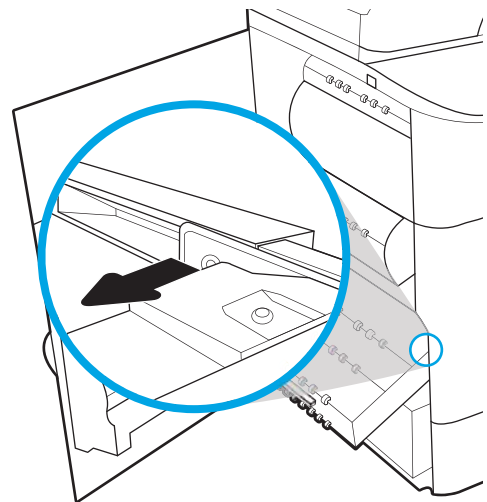

5. Remove the new service fluid container from its packaging.

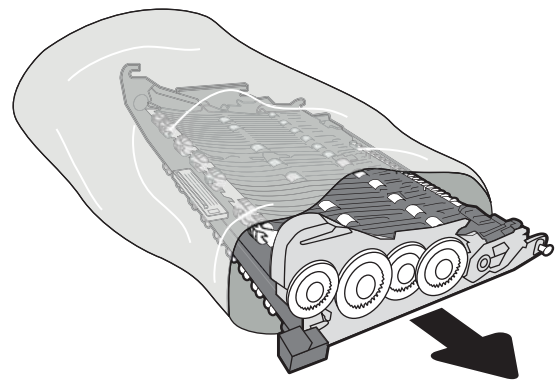

6. Insert the right end of the service fluid container into the alignment track first.

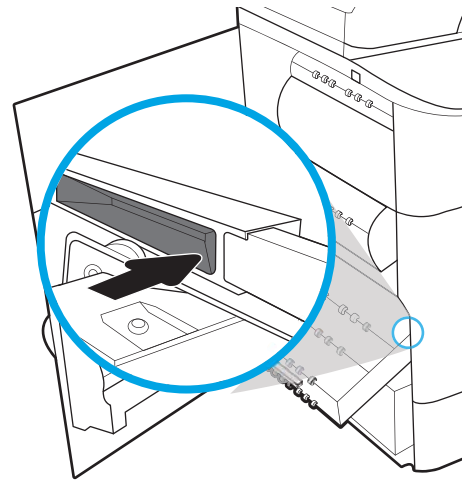

7. Insert the left end of the service fluid container into the alignment track, and then lock the latch that holds the unit in the track.

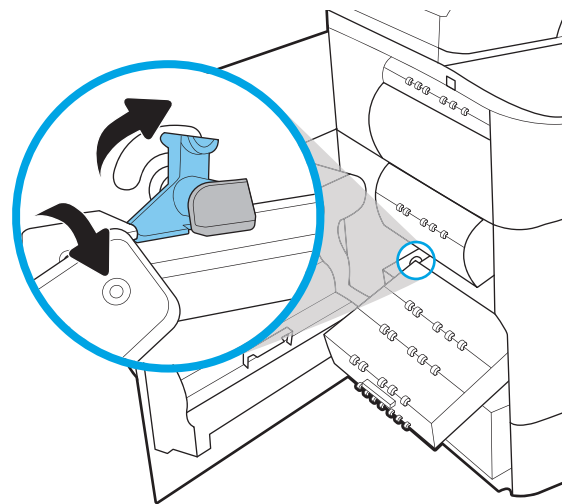

8. Push the service fluid container into the printer.

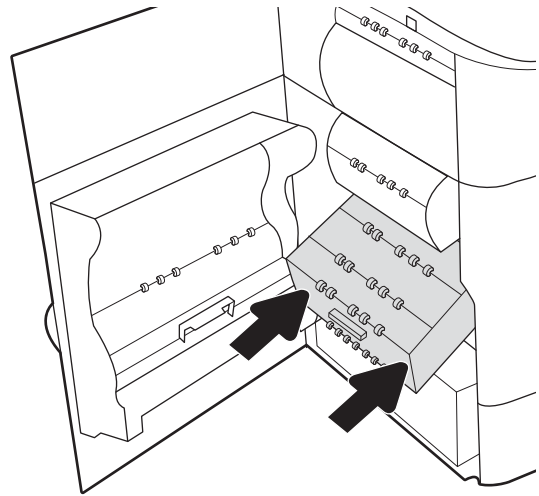

9. Close the left door.

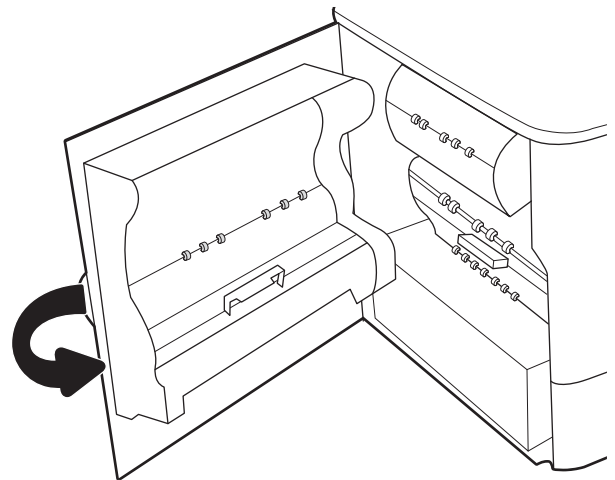

Replace the staple cartridge (785zs model only)

1. Open the stapler door.

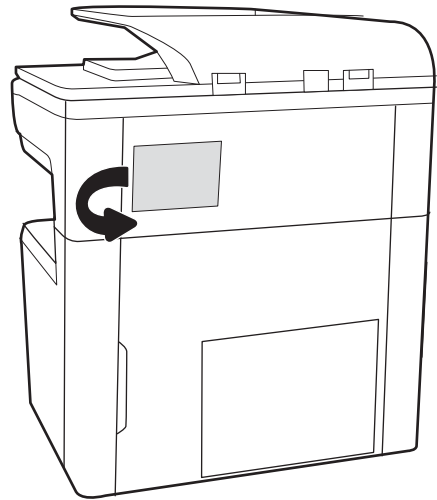

2. Pull the colored handle on the staple cartridge, and then pull the staple cartridge straight out.

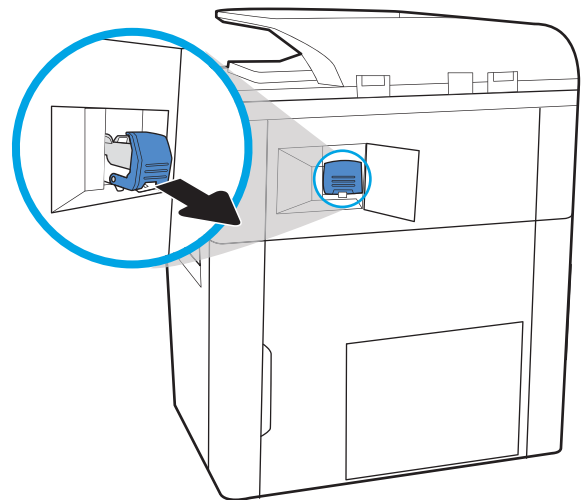

3. Insert the new staple cartridge into the stapler and push on the colored handle until it snaps into place.

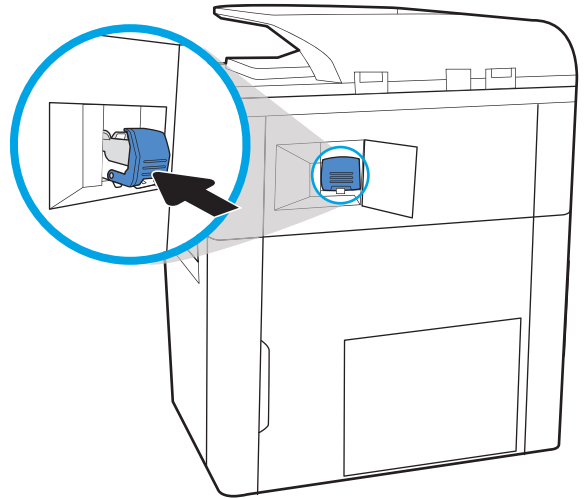

4. Close the stapler door.

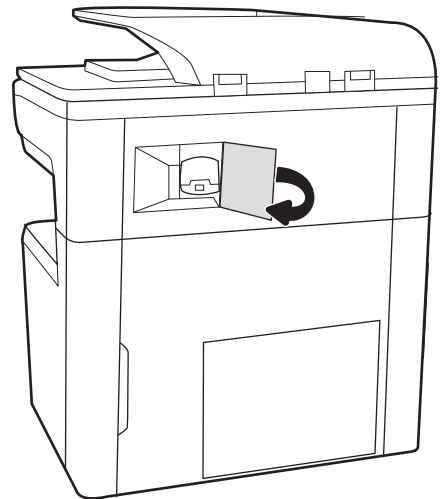

4 Print

- [Print tasks \(Windows\)](#)
- [Print tasks \(OS X\)](#)
- [Store print jobs on the printer to print later or print privately](#)
- [Mobile printing](#)
- [Print from the USB port](#)

For more information:

The following information is correct at the time of publication. For current information, see www.hp.com/support/pwcolor780MFP or www.hp.com/support/pwcolor785MFP.

HP's all-inclusive help for the printer includes the following information:

- Install and configure
- Learn and use
- Solve problems
- Download software and firmware updates
- Join support forums
- Find warranty and regulatory information

Print tasks (Windows)

How to print (Windows)

The following procedure describes the basic printing process for Windows.

1. From the software program, select the **Print** option.
2. Select the printer from the list of printers. To change settings, click the **Properties** or **Preferences** button to open the print driver.

 **NOTE:** The name of the button varies for different software programs.

 **NOTE:** In Windows 10, 8.1, and 8, these applications will have a different layout with different features from what is described below for desktop applications. To access the print feature from a Start screen app, complete the following steps:

- **Windows 10:** Select **Print**, and then select the printer.
- **Windows 8.1 or 8:** Select **Devices**, select **Print**, and then select the printer.

For the HP PCL-6 V4 driver, the HP AiO Printer Remote application downloads additional driver features when **More settings** is selected.

 **NOTE:** For more information, click the Help (?) button in the print driver.

3. Click the tabs in the print driver to configure the available options. For example, set the paper orientation on the **Finishing** tab, and set the paper source, paper type, paper size, and quality settings on the **Paper/Quality** tab.
4. Click the **OK** button to return to the **Print** dialog box. Select the number of copies to print from this screen.
5. Click the **Print** button to print the job.

Automatically print on both sides (Windows)

Use this procedure for printers that have an automatic duplexer installed. If the printer does not have an automatic duplexer installed, or to print on paper types that the duplexer does not support, print on both sides manually.

1. From the software program, select the **Print** option.
2. Select the printer from the list of printers, and then click the **Properties** or **Preferences** button to open the print driver.

 **NOTE:** The name of the button varies for different software programs.

 **NOTE:** In Windows 10, 8.1, and 8, these applications will have a different layout with different features from what is described below for desktop applications. To access the print feature from a Start screen app, complete the following steps:

- **Windows 10:** Select **Print**, and then select the printer.
- **Windows 8.1 or 8:** Select **Devices**, select **Print**, and then select the printer.

For the HP PCL-6 V4 driver, the HP AiO Printer Remote application downloads additional driver features when **More settings** is selected.

3. Click the **Finishing** tab.
4. Select **Print on both sides**. Click **OK** to close the **Document Properties** dialog.
5. In the **Print** dialog, click **Print** to print the job.

Manually print on both sides (Windows)

Use this procedure for printers that do not have an automatic duplexer installed or to print on paper that the duplexer does not support.

1. From the software program, select the **Print** option.
2. Select the printer from the list of printers, and then click the **Properties** or **Preferences** button to open the print driver.

 **NOTE:** The name of the button varies for different software programs.

 **NOTE:** In Windows 10, 8.1, and 8, these applications will have a different layout with different features from what is described below for desktop applications. To access the print feature from a Start screen app, complete the following steps:

- **Windows 10:** Select **Print**, and then select the printer.
- **Windows 8.1 or 8:** Select **Devices**, select **Print**, and then select the printer.

For the HP PCL-6 V4 driver, the HP AiO Printer Remote application downloads additional driver features when **More settings** is selected.

3. Click the **Finishing** tab.
4. Select **Print on both sides (manually)**, and then click **OK** to close the **Document Properties** dialog.
5. In the **Print** dialog, click **Print** to print the first side of the job.
6. Retrieve the printed stack from the output bin, and place it in Tray 1.
7. If prompted, select the appropriate control panel button to continue.

Print multiple pages per sheet (Windows)

1. From the software program, select the **Print** option.
2. Select the printer from the list of printers, and then click the **Properties** or **Preferences** button to open the print driver.

 **NOTE:** The name of the button varies for different software programs.

 **NOTE:** In Windows 10, 8.1, and 8, these applications will have a different layout with different features from what is described below for desktop applications. To access the print feature from a Start screen app, complete the following steps:

- **Windows 10:** Select **Print**, and then select the printer.
- **Windows 8.1 or 8:** Select **Devices**, select **Print**, and then select the printer.

For the HP PCL-6 V4 driver, the HP AiO Printer Remote application downloads additional driver features when **More settings** is selected.

3. Click the **Finishing** tab.
4. Select the number of pages per sheet from the **Pages per sheet** drop-down.
5. Select the correct **Print page borders**, **Page order**, and **Orientation** options. Click **OK** to close the **Document Properties** dialog.
6. In the **Print** dialog, click **Print** to print the job.

Select the paper type (Windows)

1. From the software program, select the **Print** option.
2. Select the printer from the list of printers, and then click the **Properties** or **Preferences** button to open the print driver.



NOTE: The name of the button varies for different software programs.



NOTE: In Windows 10, 8.1, and 8, these applications will have a different layout with different features from what is described below for desktop applications. To access the print feature from a Start screen app, complete the following steps:

- **Windows 10:** Select **Print**, and then select the printer.
- **Windows 8.1 or 8:** Select **Devices**, select **Print**, and then select the printer.

For the HP PCL-6 V4 driver, the HP AiO Printer Remote application downloads additional driver features when **More settings** is selected.

3. Click the **Paper/Quality** tab.
4. Select the paper type from the **Paper type** drop-down list.
5. Click **OK** to close the **Document Properties** dialog. In the **Print** dialog, click **Print** to print the job.
If the tray needs to be configured, a tray configuration message displays on the printer control panel.
6. Load the tray with the specified type and size of paper, and then close the tray.
7. Touch the **OK** button to accept the detected type and size, or touch the **Modify** button to choose a different paper size or type.
8. Select the correct type and size, and then touch the **OK** button.

Additional print tasks

Go to www.hp.com/support/pwcolor780MFP or www.hp.com/support/pwcolor785MFP.

Instructions are available for performing specific print tasks, such as the following:

- Create and use printing shortcuts or presets
- Select the paper size, or use a custom paper size
- Select the page orientation
- Create a booklet
- Scale a document to fit a specific paper size
- Print the first or last pages of the document on different paper
- Print watermarks on a document

Print tasks (OS X)

How to print (OS X)

The following procedure describes the basic printing process for OS X.

1. Click the **File** menu, and then click the **Print** option.
2. Select the printer.
3. Click **Show Details** or **Copies & Pages**, and then select other menus to adjust the print settings.

 **NOTE:** The name of the item varies for different software programs.

4. Click the **Print** button.

Automatically print on both sides (OS X)

 **NOTE:** This information applies to printers that include an automatic duplexer.

 **NOTE:** This feature is available if you install the HP print driver. It might not be available if you are using AirPrint.

1. Click the **File** menu, and then click the **Print** option.
2. Select the printer.
3. Click **Show Details** or **Copies & Pages**, and then click the **Layout** menu.

 **NOTE:** The name of the item varies for different software programs.

4. Select a binding option from the **Two-Sided** drop-down list.
5. Click the **Print** button.

Manually print on both sides (OS X)

 **NOTE:** This feature is available if you install the HP print driver. It might not be available if you are using AirPrint.

1. Click the **File** menu, and then click the **Print** option.
2. Select the printer.
3. Click **Show Details** or **Copies & Pages**, and then click the **Manual Duplex** menu.

 **NOTE:** The name of the item varies for different software programs.

4. Click the **Manual Duplex** box, and select a binding option.
5. Click the **Print** button.
6. Go to the printer, and remove any blank paper that is in Tray 1.
7. Retrieve the printed stack from the output bin and place it with the printed-side facing down in the input tray.
8. If prompted, touch the appropriate control panel button to continue.

Print multiple pages per sheet (OS X)

1. Click the **File** menu, and then click the **Print** option.
2. Select the printer.
3. Click **Show Details** or **Copies & Pages**, and then click the **Layout** menu.

 **NOTE:** The name of the item varies for different software programs.

4. From the **Pages per Sheet** drop-down list, select the number of pages that you want to print on each sheet.
5. In the **Layout Direction** area, select the order and placement of the pages on the sheet.
6. From the **Borders** menu, select the type of border to print around each page on the sheet.
7. Click the **Print** button.

Select the paper type (OS X)

1. Click the **File** menu, and then click the **Print** option.
2. Select the printer.
3. Click **Show Details** or **Copies & Pages**, and then click the **Media & Quality** menu or the **Paper/Quality** menu.

 **NOTE:** The name of the item varies for different software programs.

4. Select from the **Media & Quality** or **Paper/Quality** options.

 **NOTE:** This list contains the master set of options available. Some options are not available on all printers.

- **Media Type:** Select the option for the type of paper for the print job.
 - **Print Quality:** Select the resolution level for the print job.
 - **Edge-To-Edge Printing:** Select this option to print close to the paper edges.
5. Click the **Print** button.

Additional print tasks

Go to www.hp.com/support/pwcolor780MFP or www.hp.com/support/pwcolor785MFP.

Instructions are available for performing specific print tasks, such as the following:

- Create and use printing shortcuts or presets
- Select the paper size, or use a custom paper size
- Select the page orientation
- Create a booklet
- Scale a document to fit a specific paper size
- Print the first or last pages of the document on different paper
- Print watermarks on a document

Store print jobs on the printer to print later or print privately

Introduction

The following information provides procedures for creating and printing documents that are stored on the printer. These jobs can be printed at a later time or printed privately.

- [Create a stored job \(Windows\)](#)
- [Create a stored job \(OS X\)](#)
- [Print a stored job](#)
- [Delete a stored job](#)
- [Information sent to printer for Job Accounting purposes](#)

Create a stored job (Windows)

Store jobs on the printer for private or delayed printing.

1. From the software program, select the **Print** option.
2. Select the printer from the list of printers, and then select **Properties** or **Preferences** (the name varies for different software programs).

 **NOTE:** The name of the button varies for different software programs.

 **NOTE:** In Windows 10, 8.1, and 8, these applications will have a different layout with different features from what is described below for desktop applications. To access the print feature from a Start screen app, complete the following steps:

- **Windows 10:** Select **Print**, and then select the printer.
- **Windows 8.1 or 8:** Select **Devices**, select **Print**, and then select the printer.

For the HP PCL-6 V4 driver, the HP AiO Printer Remote application downloads additional driver features when **More settings** is selected.

3. Click the **Job Storage** tab.
4. Select a **Job Storage Mode** option.
 - **Proof and Hold:** Print and proof one copy of a job, and then print more copies.
 - **Personal Job:** The job does not print until you request it at the printer control panel. For this job-storage mode, you can select one of the **Make Job Private/Secure** options. If you assign a personal identification number (PIN) to the job, you must provide the required PIN at the control panel. If you encrypt the job, you must provide the required password at the control panel. The print job is deleted from memory after it prints and is lost if the printer loses power.
 - **Quick Copy:** Print the requested number of copies of a job and store a copy of the job in the printer memory so you can print it again later.
 - **Stored Job:** Store a job on the printer and allow other users to print the job at any time. For this job-storage mode, you can select one of the **Make Job Private/Secure** options. If you assign a personal identification number (PIN) to the job, the person who prints the job must provide the required PIN at

the control panel. If you encrypt the job, the person who prints the job must provide the required password at the control panel.

5. To use a custom user name or job name, click the **Custom** button, and then enter the user name or the job name.

Select which option to use if another stored job already has that name:

- **Use Job Name + (1-99):** Append a unique number to the end of the job name.
 - **Replace Existing File:** Overwrite the existing stored job with the new one.
6. Click the **OK** button to close the **Document Properties** dialog box. In the **Print** dialog box, click the **Print** button to print the job.

Create a stored job (OS X)

Store jobs on the printer for private or delayed printing.

1. Click the **File** menu, and then click the **Print** option.
2. In the **Printer** menu, select the printer.
3. By default, the print driver displays the **Copies & Pages** menu. Open the menus drop-down list, and then click the **Job Storage** menu.
4. In the **Mode** drop-down list, select the type of stored job.
 - **Proof and Hold:** Print and proof one copy of a job, and then print more copies.
 - **Personal Job:** The job does not print until someone requests it at the printer control panel. If the job has a personal identification number (PIN), provide the required PIN at the control panel. The print job is deleted from memory after it prints and is lost if the printer loses power.
 - **Quick Copy:** Print the requested number of copies of a job and store a copy of the job in the printer memory to print it again later.
 - **Stored Job:** Store a job on the printer and allow other users to print the job at any time. If the job has a personal identification number (PIN), the person who prints the job must provide the required PIN at the control panel.
5. To use a custom user name or job name, click the **Custom** button, and then enter the user name or the job name.

Select which option to use if another stored job already has that name.

- **Use Job Name + (1-99):** Append a unique number to the end of the job name.
 - **Replace Existing File:** Overwrite the existing stored job with the new one.
6. If you selected the **Stored Job** or **Personal Job** option in step 4, you can protect the job with a PIN. Type a 4-digit number in the **Use PIN to Print** field. When other people attempt to print this job, the printer prompts them to enter this PIN number.
 7. Click the **Print** button to process the job.

Print a stored job

Use this procedure to print a document that is in a job storage folder on the printer.

1. From the Home screen on the printer control panel, select [Print](#), and then select [Print from Job Storage](#).
2. Under [Stored Jobs to Print](#), select [Choose](#), and then select the folder where the document is saved.
3. Select the document, and then touch [Select](#).

If the document is private, enter the four-digit PIN in the [Password](#) field, and then select [OK](#).

4. To adjust the number of copies, select the box to the left of the [Print](#) button, and then select the number of copies from the keypad that opens. Select the Close  button to close the keypad.
5. Select [Print](#) to print the document.

Delete a stored job

You can delete documents that have been saved to when printer when they are no longer needed. You can also adjust the maximum number of jobs for the printer to store.

- [Delete a job that is stored on the printer](#)
- [Change the job storage limit](#)

Delete a job that is stored on the printer

Follow these steps to delete a job that is stored in the printer memory.

1. From the Home screen on the printer control panel, select [Print](#).
2. Select [Print from Job Storage](#).
3. Select [Choose](#), and then select the name of the folder where the job is stored.
4. Select the name of the job.
5. Select the Trash  button to delete the job.

If the job is private or encrypted, enter the PIN or password, and then select [OK](#).

6. Select [Delete Jobs](#) on the confirmation prompt.

Change the job storage limit

When a new job is stored in the printer memory, the printer overwrites any previous jobs with the same user and job name. If a job is not already stored under the same user and job name, and the printer needs additional space, the printer might delete other stored jobs starting with the oldest. Follow these steps to change the number of jobs that the printer can store:

1. From the Home screen on the printer control panel, select [Settings](#).
2. Open the following menus:
 - [Copy/Print or Print](#)
 - [Manage Stored Jobs](#)
 - [Temporary Job Storage Limit](#)

3. Use the keypad to enter the number of jobs that the printer stores.
4. Select **Done** to save the setting.

Information sent to printer for Job Accounting purposes

Printing jobs sent from drivers on the client (e.g., PC) may send personally identifiable information to HP's Printing and Imaging devices. This information may include, but is not limited to, user name and client name from which the job originated that may be used for job accounting purposes, as determined by the Administrator of the printing device. This same information may also be stored with the job on the mass storage device (e.g., disk drive) of the printing device when using the job storage feature.

Mobile printing

Introduction

HP offers multiple mobile and ePrint solutions to enable easy printing to an HP printer from a laptop, tablet, smartphone, or other mobile device. To see the full list and to determine the best choice, go to www.hp.com/go/MobilePrinting.



NOTE: Update the printer firmware to ensure all mobile printing and ePrint capabilities are supported.

- [Wi-Fi Direct and NFC Connect and Print](#)
- [HP ePrint via email](#)
- [HP ePrint software](#)
- [AirPrint](#)
- [Android embedded printing](#)

Wi-Fi Direct and NFC Connect and Print

HP provides Wi-Fi Direct Print and NFC (Near Field Communication) printing for printers with a supported HP Jetdirect 3000w NFC/Wireless Accessory. This accessory is available as an option for HP printers that include a hardware-integration pocket (HIP).

Wi-Fi Direct Print and NFC connect and print enable Wi-Fi capable (mobile) devices to make a wireless network connection directly to the printer without using a wireless router.

The printer does not need to be connected to the network for this mobile walk-up printing to work.





Use Wi-Fi Direct Print to print wirelessly from the following devices:

- iPhone, iPad, or iPod touch using Apple AirPrint or the HP ePrint app
- Android mobile devices using the HP ePrint App or the Android embedded print solution
- PC and Mac devices using the HP ePrint Software
- Windows 10 mobile devices

For more information on wireless printing, go to www.hp.com/go/mobileprinting.

NFC and Wi-Fi Direct Print capabilities can be enabled or disabled from the printer control panel.

1. From the Home screen on the printer control panel, select **Settings**.
2. Open the following menus:
 - **Networking**
 - **Wi-Fi Direct**
 - **Status**
3. Select **On**, and then select **OK** to enable wireless printing.

 **NOTE:** In environments where more than one model of the same printer is installed, it might be helpful to provide each printer a unique Wi-Fi Direct Name for easier printer identification for HP Wi-Fi Direct printing. The Wireless network names, e.g., Wireless, Wi-Fi Direct, etc. are available on the Information screen by selecting the Information  icon, and then selecting the Network  icon or the Wireless  icon.

Complete the following procedure to change the printer Wi-Fi Direct name:

1. From the Home screen on the printer control panel, select [Settings](#).
2. Open the following menus:
 - [Networking](#)
 - [Wi-Fi Direct](#)
 - [Wi-Fi Direct Name](#)
3. Use the keypad to change the name in the [Wi-Fi Direct Name](#) text field, and then select [OK](#).



HP ePrint via email

Use HP ePrint to print documents by sending them as an email attachment to the printer's email address from any email enabled device.

To use HP ePrint, the printer must meet these requirements:

- The printer must be connected to a wired or wireless network and have Internet access.
- HP Web Services must be enabled on the printer, and the printer must be registered with HP Connected.

Follow this procedure to enable HP Web Services and register with HP Connected:

1. Open the HP Embedded Web Server (EWS):
 - a. From the Home screen on the printer control panel, select the Information  icon, and then select the Network  icon to display the IP address or host name.
 - b. From a computer on the same network as the printer, open a web browser. In the address line, type the IP address or host name exactly as it displays on the printer control panel. Press the [Enter](#) key on the computer keyboard. The EWS opens.

 <https://10.10.XXXX/>

 **NOTE:** If the web browser displays a message indicating that accessing the website might not be safe, select the option to continue to the website. Accessing this website will not harm the computer.

2. Click the **HP Web Services** tab.
 3. Select the option to enable Web Services.
-  **NOTE:** Enabling Web Services might take several minutes.
-
4. Go to www.hpconnected.com to create an HP ePrint account and complete the setup process.

HP ePrint software

The HP ePrint software makes it easy to print from a Windows or Mac desktop or laptop computer to any HP ePrint-capable printer. This software makes it easy to find HP ePrint-enabled printers that are registered to your HP Connected account. The target HP printer can be located in the office or at locations across the globe.

- **Windows:** After installing the software, open the **Print** option from within your application, and then select **HP ePrint** from the installed printers list. Click the **Properties** button to configure print options.
- **OS X:** After installing the software, select **File, Print**, and then select the arrow next to **PDF** (in the bottom left of the driver screen). Select **HP ePrint**.

For Windows, the HP ePrint software supports TCP/IP printing to local network printers on the network (LAN or WAN) to products that support UPD PostScript®.

Windows and OS X both support IPP printing to LAN or WAN network-connected products that support ePCL.

Windows and OS X also both support printing PDF documents to public print locations and printing using HP ePrint via email through the cloud.

Go to www.hp.com/go/eprintssoftware for drivers and information.

 **NOTE:** For Windows, the name of the HP ePrint Software print driver is HP ePrint + JetAdvantage.

 **NOTE:** The HP ePrint software is a PDF workflow utility for OS X, and is not technically a print driver.

 **NOTE:** HP ePrint Software does not support USB printing.

AirPrint

Direct printing using Apple's AirPrint is supported for iOS and from Mac computers running OS X 10.7 Lion and newer. Use AirPrint to print directly to the printer from an iPad, iPhone (3GS or later), or iPod touch (third generation or later) in the following mobile applications:

- Mail
- Photos
- Safari
- iBooks
- Select third-party applications

To use AirPrint, the printer must be connected to the same network (sub-net) as the Apple device. For more information about using AirPrint and about which HP printers are compatible with AirPrint, go to www.hp.com/go/MobilePrinting.

 **NOTE:** Before using AirPrint with a USB connection, verify the version number. AirPrint versions 1.3 and earlier do not support USB connections.

Android embedded printing

HP's built-in print solution for Android and Kindle enables mobile devices to automatically find and print to HP printers that are either on a network or within wireless range for Wi-Fi Direct printing.

The print solution is built into the many versions of the operating system.



NOTE: If printing is not available on your device, go to the [Google Play > Android apps](#) and install the HP Print Service Plugin.

For more information on how to use Android embedded printing and which Android devices are supported, go to www.hp.com/go/MobilePrinting.

Print from the USB port

Introduction

This printer features easy-access USB printing, for quickly printing files without sending them from a computer. The printer accepts standard USB flash drives in the USB port near the control panel. It supports the following types of files:

- .pdf
- .prn
- .pcl
- .ps
- .cht
- [Enable the USB port for printing](#)
- [Print USB documents](#)



Enable the USB port for printing

The USB port is disabled by default. Before using this feature, enable the USB port. Use one of the following methods to enable the port:

Method one: Enable the USB port from the printer control panel

1. From the Home screen on the printer control panel, select [Settings](#).
2. Open the following menus
 - [Copy/Print](#) or [Print](#)
 - [Enable Device USB](#)
3. Select [Enabled](#) to enable the USB port.

Method two: Enable the USB port from the HP Embedded Web Server (network-connected printers only)

1. From the Home screen on the printer control panel, select the Information  icon, and then select the Network  icon to display the IP address or host name
2. Open a web browser, and in the address line, type the IP address exactly as it displays on the printer control panel. Press the [Enter](#) key on the computer keyboard. The EWS opens.

 <https://10.10.XX.XXX/>

 **NOTE:** If the web browser displays a **There is a problem with this website's security certificate** message when attempting to open the EWS, click **Continue to this website (not recommended)**.

Choosing **Continue to this website (not recommended)** will not harm the computer while navigating within the EWS for the HP printer.

3. Select the **Copy/Print** tab for MFP models or the **Print** tab for SFP models.
4. In the left menu, select **Print from USB Drive Settings**.

5. Select **Enable Print from USB Drive**.
6. Click **Apply**.

Print USB documents

1. Insert the USB flash drive into the easy-access USB port.



NOTE: The port might be covered. For some printers, the cover flips open. For other printers, pull the cover straight out to remove it.

2. From the Home screen on the printer control panel, select **Print**.
3. Select **Print from USB Drive**.
4. Select **Choose**, select the name of the document to print, and then touch **Select**.



NOTE: The document might be in a folder. Open folders as necessary.

5. To adjust the number of copies, touch the box to the left of the **Print** button, and then select the number of copies from the keypad that opens. Select the Close  button to close the keypad.
6. Select **Print** to print the document.

5 Copy

- [Make a copy](#)
- [Copy on both sides \(duplex\)](#)
- [Additional copy tasks](#)

For more information:

The following information is correct at the time of publication. For current information, see www.hp.com/support/pwcolor780MFP or www.hp.com/support/pwcolor785MFP.

HP's all-inclusive help for the printer includes the following information:

- Install and configure
- Learn and use
- Solve problems
- Download software and firmware updates
- Join support forums
- Find warranty and regulatory information

Make a copy

Follow these steps to make a copy from the scanner glass or the document feeder.

1. Place the document face-down on the scanner glass, or place it face-up in the document feeder and adjust the paper guides to fit the size of the document.
2. From the Home screen on the printer control panel, select [Copy](#).
3. Select settings from the [Sides](#) menu and the [Color/Black](#) menu (color printers), and then select [Done](#).
4. If you are using a Quick Set, select [Load](#) under [Quick Sets and Defaults](#). Select the Quick Set from the list, and then select [Load](#) in the lower right corner.

 **NOTE:** [Quick Sets](#) are predefined copy settings for various types of output, such as [Text](#), [Photograph](#), and [High Quality](#).

5. To adjust settings, such as [Reduce/Enlarge](#) and [Content Orientation](#), select [Options](#) in the lower left corner, and then select the settings from the [Options](#) menus. Select [Done](#) if prompted.
6. Optional Preview: Touch the right pane of the screen to preview the document. You can use the [Expand](#) and [Collapse](#) buttons on the left side of the preview pane to expand and collapse the preview screen.

Expand button



Collapse button



Use the buttons on the right of the screen to adjust the preview options and to rearrange, rotate, insert, or remove pages.



Toggle between the two-page view and the thumbnail view. More options are available in the thumbnail view than in the two-page view.



Zoom in or out on the selected page.

NOTE: Select only one page at a time to use these buttons.



Rotate the page 180 degrees.

NOTE: This button is available only in the thumbnail view.



Delete the selected pages.

NOTE: This button is available only in the thumbnail view.



Rearrange the pages within the document. Select one or more pages and move them to the left or right.

NOTE: These buttons are available only in the thumbnail view.



Add a page to the document. The printer prompts you to scan additional pages.



Clear the changes made in the preview and start over.

7. To adjust the number of copies, touch the box to the left of the [Copy](#) button, and then select the number of copies from the keypad that opens. Select the Close  button to close the keypad.
8. When the document is ready, select [Copy](#) to begin copying.

Copy on both sides (duplex)

1. Place the document face-down on the scanner glass, or place it face-up in the document feeder and adjust the paper guides to fit the size of the document.
 2. From the Home screen on the printer control panel, select [Copy](#).
 3. Select the arrow under [Sides](#) to view available options.
 4. In the [Original Sides](#) section, select the option that describes the original document:
 - Use [1-sided](#) for originals that are printed on one side of the page.
 - Use [2-sided](#) for originals that are printed on both sides of the page.
 - Enable or disable [Pages Flip Up](#) to determine on which edge of the page a 2-sided original flips.
 5. In the [Output Sides](#) section, select one of these options:
 - [Match original](#): The output will match the format of the original. For example, if the original is 1-sided, the output will be 1-sided. However, if the administrator has restricted 1-sided printing and the original is 1-sided, the output will be 2-sided book-style.
-
-  **NOTE:** This feature is not available for all firmware versions. You might need to update the printer firmware to use this feature.
-
- [1-sided](#): The output will be 1-sided. However, if the administrator has restricted 1-sided printing, the output will be 2-sided book-style.
 - [2-sided](#): The output will be 2-sided.
 - Enable or disable [Pages Flip Up](#) to determine on which edge of the page the 2-sided output flips.
6. Select [Done](#).
 7. Adjust any other settings as needed. Select [Done](#) for each setting if prompted.
 8. Optional Preview: Touch the right pane of the screen to preview the document. You can use the [Expand](#) and [Collapse](#) buttons on the left side of the preview pane to expand and collapse the preview screen.

Expand button



Collapse button



Use the buttons on the right of the screen to adjust the preview options and to rearrange, rotate, insert, or remove pages.



Toggle between the two-page view and the thumbnail view. More options are available in the thumbnail view than in the two-page view.



Zoom in or out on the selected page.

NOTE: Select only one page at a time to use these buttons.



Rotate the page 180 degrees.

NOTE: This button is available only in the thumbnail view.



Delete the selected pages.

NOTE: This button is available only in the thumbnail view.



Rearrange the pages within the document. Select one or more pages and move them to the left or right.

NOTE: These buttons are available only in the thumbnail view.



Add a page to the document. The printer prompts you to scan additional pages.



Clear the changes made in the preview and start over.

9. To adjust the number of copies, touch the box to the left of the **Copy** button, and then select the number of copies from the keypad that opens. Select the Close  button to close the keypad.
10. When the document is ready, select **Copy** to begin copying.

Additional copy tasks

Go to www.hp.com/support/pwcolor780MFP or www.hp.com/support/pwcolor785MFP.

Instructions are available for performing specific copy tasks, such as the following:

- Copy or scan pages from books or other bound documents
- Copy mixed-size documents
- Copy or scan both sides of an identification card
- Copy or scan a document into a booklet format

6 Scan

- [Set up Scan to Email](#)
- [Set up Scan to Network Folder](#)
- [Set up Scan to USB Drive](#)
- [Set up Scan to SharePoint® \(Flow models only\)](#)
- [Scan to email](#)
- [Scan to network folder](#)
- [Scan to USB drive](#)
- [Scan to SharePoint](#)
- [Scan to job storage](#)
- [HP JetAdvantage business solutions](#)
- [Additional scan tasks](#)

For more information:

The following information is correct at the time of publication. For current information, see www.hp.com/support/pwcolor780MFP or www.hp.com/support/pwcolor785MFP.

HP's all-inclusive help for the printer includes the following information:

- Install and configure
- Learn and use
- Solve problems
- Download software and firmware updates
- Join support forums
- Find warranty and regulatory information

Set up Scan to Email

- [Introduction](#)
- [Before you begin](#)
- [Step one: Access the HP Embedded Web Server \(EWS\)](#)
- [Step two: Configure the Network Identification settings](#)
- [Step three: Configure the Scan to Email feature](#)
- [Step four: Configure the Quick Sets \(optional\)](#)
- [Step five: Set up Scan to Email to use Office 365 Outlook \(optional\)](#)

Introduction

The printer has a feature that enables it to scan a document and send it to one or more email addresses. To use this scan feature, the printer must be connected to a network; however, the feature is not available until it has been configured. There are two methods for configuring Scan to Email, the **Scan to Email Setup Wizard** for basic and **Email Setup** for advanced. Use the following information to set up the Scan to Email feature.

Before you begin

To set up the Scan to Email feature, the printer must have an active network connection.

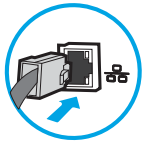

Administrators need the following information before beginning the configuration process.



- Administrative access to the printer
- DNS suffix (e.g., companyname.com)
- SMTP server (e.g., smtp.mycompany.com)

 **NOTE:** If you do not know the SMTP server name, SMTP port number, or authentication information, contact the email/Internet service provider or system administrator for the information. SMTP server names and port names are typically found by doing an Internet search. For example, use terms like "Gmail smtp server name" or "Yahoo smtp server name" to search.

- SMTP server authentication requirements for outgoing email messages, including the user name and password used for authentication, if applicable.

 **NOTE:** Consult your email service provider's documentation for information on digital sending limits for your email account. Some providers may temporarily lock your account if you exceed your sending limit.

Step one: Access the HP Embedded Web Server (EWS)

1. From the Home screen on the printer control panel, touch the Information  icon, and then touch the Network  icon to display the IP address or host name.

- Open a web browser, and in the address line, type the IP address or host name exactly as it displays on the printer control panel. Press the **Enter** key on the computer keyboard. The EWS opens.

 <https://10.10.XX.XXX/>

 **NOTE:** If the web browser displays a message indicating that accessing the website might not be safe, select the option to continue to the website. Accessing this website will not harm the computer.

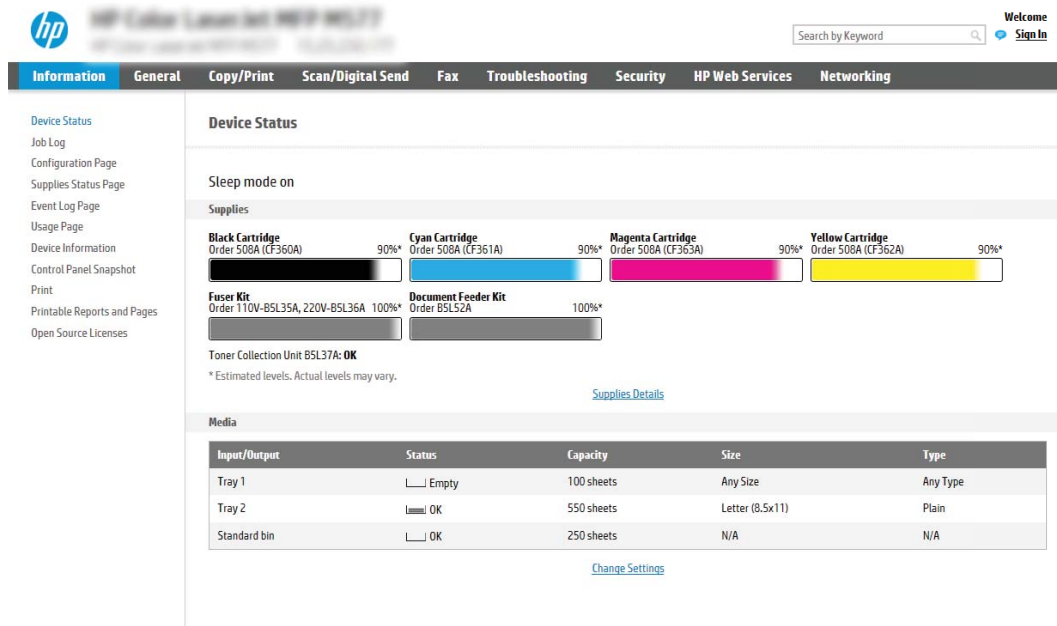

Supplies

Black Cartridge	Cyan Cartridge	Magenta Cartridge	Yellow Cartridge
Order 508A (CF360A) 90%*	Order 508A (CF361A) 90%*	Order 508A (CF363A) 90%*	Order 508A (CF362A) 90%*

Fuser Kit Order 110V-B5L35A, 220V-B5L36A 100%* **Document Feeder Kit** Order B5L52A 100%*

Toner Collection Unit B5L37A: **OK**

* Estimated levels. Actual levels may vary.

[Supplies Details](#)

Media

Input/Output	Status	Capacity	Size	Type
Tray 1	Empty	100 sheets	Any Size	Any Type
Tray 2	OK	550 sheets	Letter (8.5x11)	Plain
Standard bin	OK	250 sheets	N/A	N/A

[Change Settings](#)

Step two: Configure the Network Identification settings

 **NOTE:** Configuring email setup on the **Networking** tab is an advanced process and might require the assistance of a system administrator.

- Using the EWS top navigation tabs, click **Networking**.

 **NOTE:** For configuring the network settings for use with Office 365, see "Step five: Set up Scan to Email to use Office 365 Outlook (optional)."

- In the left navigation pane, click **TCP/IP Settings**. A username/password might be required to access the **Network Identification** tab of the EWS.
- On the **TCP/IP Settings** dialog, click the **Network Identification** tab.

4. If DNS is required on the network, in the **TCP/IP Domain Suffix** area, verify that the DNS suffix for the email client being used is listed. DNS suffixes have this format: *companyname.com*, *gmail.com*, etc.

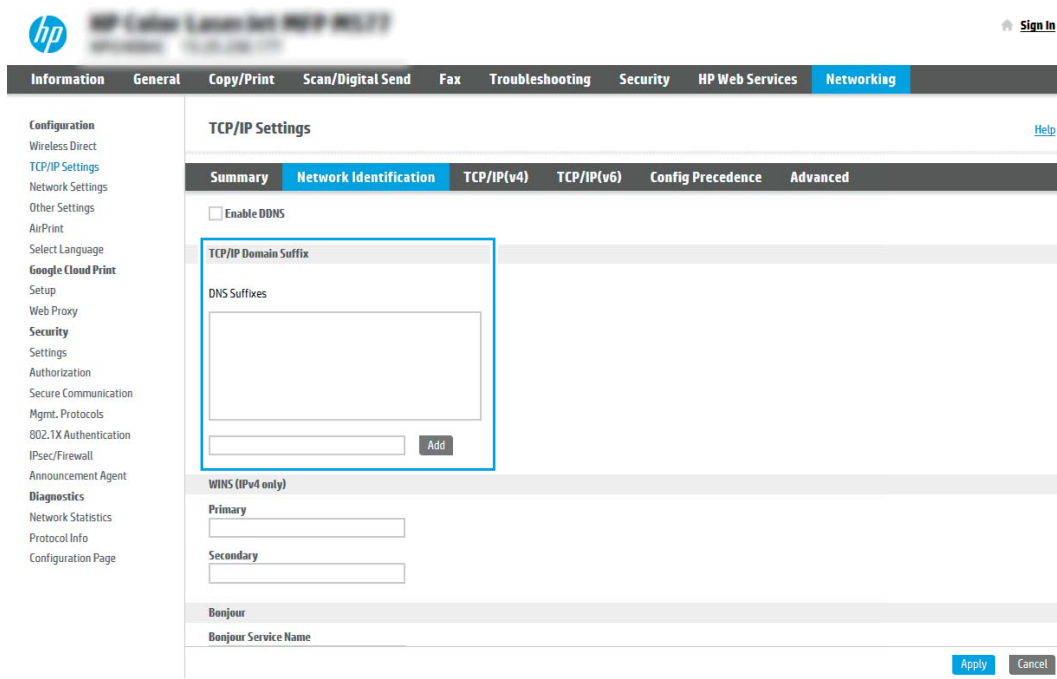

 **NOTE:** If the Domain Name suffix is not set up, use the IP address.

5. Click **Apply**.
6. Click **OK**.

Step three: Configure the Scan to Email feature

The two options for configuring Scan to Email are the **Email Setup Wizard** for basic configuration and **Email Setup** for advanced configuration. Use the following options to configure the Scan to Email feature:

- [Method one: Basic configuration using the Email Setup Wizard](#)
- [Method two: Advanced configuration using the Email Setup](#)

Method one: Basic configuration using the Email Setup Wizard

This option opens the **Email Setup Wizard** in the HP Embedded Web Server (EWS) for basic configuration.

1. Using the EWS top navigation tabs, click **Scan/Digital Send**.
2. In the left-navigation pane, click **Email and Scan to Network Folder Quick Setup Wizards**.

3. In the **Email and Scan to Network Folder Quick Setup Wizards** dialog, click the **Email Setup** link.

 **NOTE:** If a message displays indicating that the Scan to Email feature is disabled, click **Continue** to proceed with the configuration and enable the Scan to Email feature upon completion.

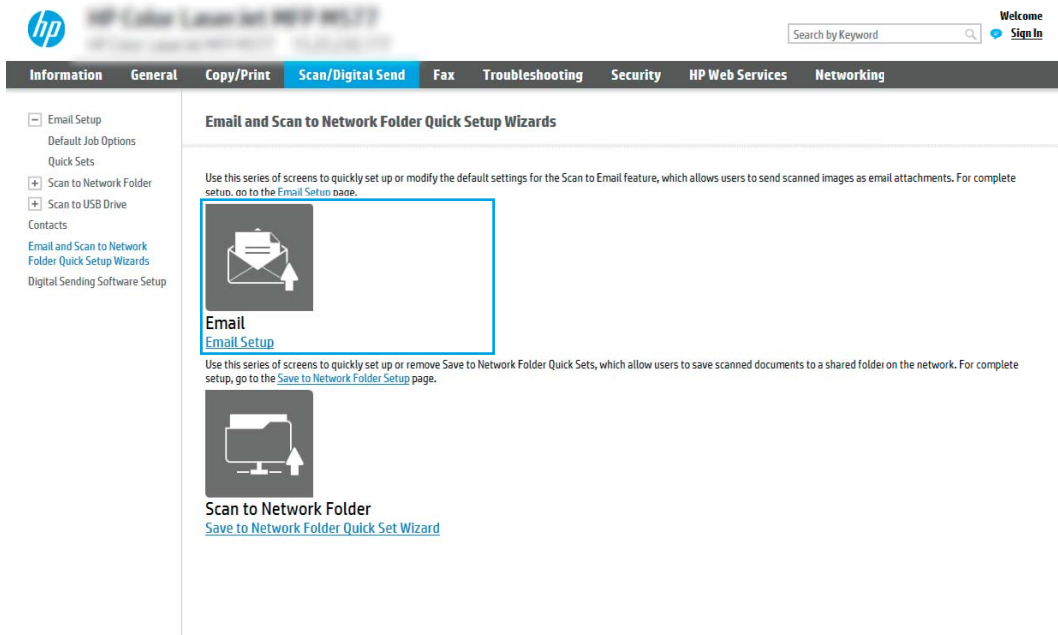

4. On the **Configure Email Servers (SMTP)** dialog, select one of the following options and complete the steps:

Option one: Use a server already in use by another function

- ▲ Select **Use a server already in use by another function**, and then click **Next**.

Option two: Search network for outgoing email server

 **NOTE:** This option finds outgoing SMTP servers inside your firewall only.

- Select **Search the network for outgoing email servers**, and then click **Next**.
- Select the appropriate server from the **Configure Email Server (SMTP)** list, and then click **Next**.
- Select the option that describes the server's authentication requirements:
 - **Server does not require authentication:** Select **Server does not require authentication**, and then click **Next**.
 - OR–
 - **Server requires authentication:** From the drop-down list, select an authentication option:
 - **Use credentials of user to connect after Sign In at the control panel:** Select **Use credentials of user to connect after Sign In at the control panel**, and then click **Next**.
 - OR–
 - **Always use these credentials:** Select **Always use these credentials**, enter the **User name** and **Password**, and then click **Next**.

Option three: Add SMTP server

- a. Select **Add SMTP server**
- b. Enter the **Server Name** and **Port Number**, and then click **Next**.

 **NOTE:** In most cases, the default port number does not need to be changed.

 **NOTE:** If you are using a hosted SMTP service such as Gmail, verify the SMTP address, port number, and SSL settings from the service provider's website or other sources. Typically, for Gmail, the SMTP address is smtp.gmail.com, port number 465, and the SSL should be enabled.

Please refer to online sources to confirm these server settings are current and valid at the time of configuration.

- c. Select the appropriate server authentication option:
 - **Server does not require authentication:** Select **Server does not require authentication**, and then click **Next**.
–OR–
 - **Server requires authentication:** Select an option from the **Server requires authentication** drop-down list:
 - **Use credentials of user to connect after Sign In at the control panel:** Select **Use credentials of user to connect after Sign In at the control panel**, and then click **Next**.
–OR–
 - **Always use these credentials:** Select **Always use these credentials**, enter the **User name** and **Password**, and then click **Next**.
5. On the **Configure Email Settings** dialog, enter the following information about for the sender's email address, and then click **Next**.

 **NOTE:** When setting up the **From**, **Subject**, and **Message** fields, if the **User editable** check box is unchecked, users will not be able to edit those fields at the printer control panel when sending an email.

Option	Description
From (Required)	Select one of the following options from the From drop-down list: <ul style="list-style-type: none">• User's address (sign-in required)• Default From: Enter a default email address and display name in the Default From Email Address and Default Display Name fields <p>NOTE: Create an email account for the printer, and use this address for the default email address.</p> <p>NOTE: Configure the email feature so that users must sign in before using it. This prevents users from sending an email from an address that is not their own.</p>

Option	Description
Subject (Optional)	Provide a default subject line for the email messages.
Message (Optional)	Create a custom message. To use this message for all emails sent from the printer, clear the User editable check box for Message .

6. In the **Configure File Scan Settings** area, set the default scanning preferences, and then click **Next**.

Option	Description
File Type	Select the default file type that the for the scanned document: <ul style="list-style-type: none"> • PDF • JPEG • TIFF • MTIFF • XPS • PDF/A
Color/Black	Select the default color setting for the scanned document: <ul style="list-style-type: none"> • Color • Black • Black/Gray • Automatically detect
Quality and File Size	Select the default output quality for the scanned document: <ul style="list-style-type: none"> • Low (small file) • Medium • High (large file)
Resolution	Select the default scan resolution for the scanned document: <ul style="list-style-type: none"> • 75 dpi • 150 dpi • 200 dpi • 300 dpi • 400 dpi • 600 dpi

7. Review the **Summary** area, and then click **Finish** to complete the setup.

Method two: Advanced configuration using the Email Setup

1. Using the EWS top navigation tabs, click **Scan/Digital Send**, and then click **Email Setup** in the left navigation pane.

 **NOTE:** By default, the Email Setup page displays the basic settings for Scan to Email setup. To access additional settings, click the **Advanced Settings** button at the bottom of the page.

2. On the **Email Setup** dialog, select the **Enable Scan to Email** check box. If this check box is not selected, the feature is unavailable at the printer control panel.

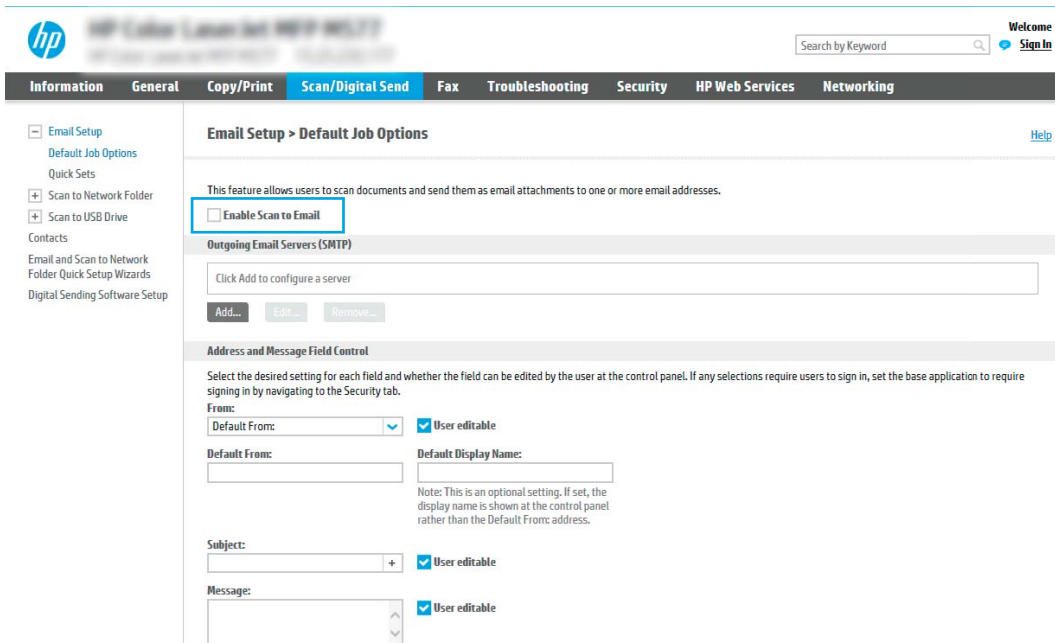

The screenshot shows the HP EWS interface for 'Email Setup > Default Job Options'. The 'Scan/Digital Send' tab is active. In the 'Email Setup' section, the 'Enable Scan to Email' checkbox is checked. Below this, the 'Outgoing Email Servers (SMTP)' section is visible, along with 'Address and Message Field Control' settings for 'From', 'Subject', and 'Messages'.

3. In the **Outgoing Email Servers (SMTP)** area, complete the steps for one of the following options:

- Select one of the displayed servers
- Click **Add** to start the SMTP wizard.
 1. In the SMTP wizard, select one of the following options:
 - **Option one: I know my SMTP server address or host name:** Enter the address of an SMTP server, and then click **Next**
 - **Option two:** If you do not know the address of the SMTP server, select **Search network for outgoing email server**, and then click **Next**. Select the server, and then click **Next**.

 **NOTE:** If an SMTP server was already created for another printer function, the **Use a server already in use by another function** option displays. Select this option, and then configure it to be used for the email function.

2. On the **Set the basic information necessary to connect to the server** dialog, set the options to use, and then click **Next**.

 **NOTE:** Some servers have problems sending or receiving emails that are larger than 5 megabytes (MB). These problems can be prevented by entering a number in **Split emails if larger than (MB)**.

 **NOTE:** In most cases, the default port number does not need to be changed. However, when using the Enable SMTP SSL Protocol option, port 587 must be used.

 **NOTE:** If you are using Google™ Gmail for email service, select the **Enable SMTP SSL Protocol** check box. Typically, for gmail, the SMTP address is smtp.gmail.com, port number 465, and the SSL should be enabled.

Please refer to online sources to confirm these server settings are current and valid at the time of configuration.

3. On the **Server Authentication Requirements** dialog, select the option that describes the server's authentication requirements:
 - **Server does not require authentication**, and then click **Next**.
 - **Server requires authentication**
 - From the drop-down box, select **Use credentials of user to connect after Sign In at the control panel**, and then click **Next**.
 - From the drop-down box, select **Always use these credentials**, enter the **Username** and **Password**, and then click **Next**.

 **NOTE:** If using a signed-in user's credentials, set email to require sign in by the user on the printer control panel. Deny device guest access to email by clearing the check box for email in the **Device Guest** column in the **Sign in and Permission Policies** area on the **Access Control** dialog of the **Security** tab. The icon in the check box changes from a check mark to a lock.

4. On the **Server Usage** dialog, choose the printer functions that will send email through this SMTP server, and then click the **Next** button.

 **NOTE:** If the server requires authentication, a user name and password for sending automatic alerts and reports from the printer will be required.

5. On the **Summary and Test** dialog, enter a valid email address in the **Send test email to:** field, and then click **Test**.
6. Verify that all of the settings are correct, and then click **Finish** to complete the outgoing email server set up.

4. In the **Address and Message Field Control** area, enter a **From:** setting and any of the other optional settings.

Address and Message Field Control settings:

Feature	Description
Address Field Restrictions ¹	<p>Specify whether users must select an email address from an address book or whether users are allowed to enter in an email address manually.</p> <p>CAUTION: If Users must select from address book is selected, and any of the address fields are also set as User editable, changes to those editable fields also change the corresponding values in the address book.</p> <p>To prevent users from changing contacts in the Address Book at the printer control panel, go to the Access Control page on the Security tab, and deny Device Guest access to address book modifications.</p>
Allow invalid email address formats ¹	Select to allow an invalid email address format.
User editable	<p>To use the Default From address and Default Display Name for all emails sent from this printer (unless a user is signed in), do not select the User editable check box.</p> <p>When setting up the address fields, if the User editable check box is unchecked, users will not be able to edit those fields at the printer control panel when sending an email. For send-to-me functionality, clear the User editable check boxes for all of the address fields, including the From: To: CC:, and BCC: fields, and then set that user's send email From: their own email address and To: their own email address.</p>
Default From: and Default Display Name:	<p>Provide an email address and name to use for the From: address for the email message.</p> <p>NOTE: Create an email account for the printer, and use this address for the default email address.</p> <p>NOTE: Configure the email feature so that users must sign in before using it. This prevents users from sending an email from an address that is not their own.</p>
To: ¹	Provide a To (recipient) email address for emails.
CC: ¹	Provide a CC email address for emails.
BCC: ¹	Provide a BCC email address for emails.
Subject:	Provide a default subject line for the email messages.
Message:	Create a custom message. To use this message for all emails sent from the printer, clear or do not select the User editable check box for Message: .

¹ This setting is available only on the Advanced Settings page.

5. In the **Signing and Encryption** area, set the signing and encryption preferences.



NOTE: These settings are available only on the Advanced Settings page.

Signing and Encryption settings:

Feature	Description
Signing	<p>Select whether to sign the security certificate.</p> <p>Select the User editable check box to make this setting editable at the printer control panel.</p>
Hashing Algorithm	Select the algorithm to use for signing the certificate.
Encryption	<p>Select whether to encrypt the email.</p> <p>Select the User editable check box to make this setting editable at the printer control panel.</p>
Encryption Algorithm	Select the algorithm to use for encrypting the email.

Feature	Description
Attribute for Recipient Public Key	Enter which attribute to use to retrieve the recipient's public key certificate from LDAP.
Use the recipient public key certificate to verify the recipient	Select this setting to use the recipient's public key certificate to verify the recipient.

- In the **Notification** area, select when users will receive notifications about sent emails. The default setting is using the signed in user's email address. If the recipient email address is blank, no notification is sent.
- In the **Scan Settings** area, set the default scanning preferences.

 **NOTE:** These settings are available only on the Advanced Settings page.

Scan settings:

Feature	Description
Original Size	Select the page size of the original document.
Original Sides	Select whether the original document is single-sided or double-sided.
Optimize Text/Picture	Select to optimize for the output of a particular type of content.
Content Orientation	Select the way the content of the original document is placed on the page: Portrait or Landscape .
Background Cleanup	Select a value to remove faint images from the background or to remove a light background color.
Darkness	Select a value to adjust the darkness of the file.
Contrast	Select a value to adjust the contrast of the file.
Sharpness	Select a value to adjust the sharpness of the file.
Image Preview	Select whether to require or make optional a displayed preview of the job or to disable a preview.
Cropping Options	Select whether or not to allow a job to be cropped and the type of cropping option.
Erase Edges	Select this setting to specify the width of edge margins to be erased, in either inches or millimeters, for the front side and back side of a job.

- In the **File Settings** area, set the default file settings preferences.

File settings:

Feature	Description
File Name Prefix ¹	Set the default file name prefix used for files saved to a network folder.
File Name	Default file name for the file to be saved. Select the User editable check box to make this setting editable at the printer control panel.
File Name Suffix ¹	Set the default file name suffix used for files saved to a network folder. Duplicate filename suffix default [filename]_YYYYMMDDT
File Name Preview ¹	Enter a file name, and then click the Update Preview button.
File Numbering Format ¹	Select a file name format for when the job is divided into multiple files.

Feature	Description
Add numbering when job has just one file (ex. _1-1)	Select this setting to add numbering to a file name when the job is only one file instead of multiple files.
File Type	Select the file format for the saved file. Select the User editable check box to make this setting editable at the printer control panel.
High Compression (smaller file)	Select this setting to compress the scanned file, which reduces the file size. However, the scanning process for a High compression file might take longer than for a Normal compression file.
PDF encryption¹	If the file type is PDF, then this option encrypts the output PDF file. A password must be specified as part of the encryption. The same password must be used to open the file. The user will be prompted to enter a password prior to scanning their job if one has not been set prior to pressing start.
Resolution	Set the resolution for the file. Higher resolution images have more dots per inch (dpi), so they show more detail. Lower resolution images have fewer dots per inch and show less detail, but the file size is smaller.
Quality and File Size	Select the quality for the file. Higher-quality images require a larger file size than lower-quality images, and they take more time to send.
Color/Black	Specify whether copies are to be printed in color, black and gray, or black only.
Suppress blank pages¹	If the Suppress blank pages option is enabled, blank pages will be ignored.
Create Multiple Files¹	Select this setting to scan pages into separate files based on a predetermined maximum number of pages per file.

¹ This setting is available only on the Advanced Settings page.

- Review the selected options to verify that they are accurate, and then click **Apply** to complete the setup.

Step four: Configure the Quick Sets (optional)

Quick Sets are optional short-cut jobs that can be accessed on the main Home screen or within the Quick Sets application at the printer.

- In the **Email Setup** area of the left navigation pane, click **Quick Sets**.
- Select one of the following options:
 - Select an existing Quick Set under Quick Sets Application in the table.
 - OR-
 - Click **Add** to start the Quick Set Wizard.
- If you selected **Add**, the **Quick Sets Setup** page opens. Complete the following information:
 - Quick Set Name:** Enter a title for the new Quick Set.
 - Quick Set Description:** Enter a description of the Quick Set.
 - Quick Set Start Option:** To set how the Quick Set starts, click either **Enter application, then user presses Start** or **Start instantly when selected from the Home Screen**.
- Define the following settings for the Quick Set: Address and Message Field Control, Signing and Encryption, Notification, Scan Settings, File Settings.
- Click **Finish** to save the Quick Set.

Step five: Set up Scan to Email to use Office 365 Outlook (optional)

Introduction

Microsoft Office 365 Outlook is a cloud-based email system provided by Microsoft which uses Microsoft's Simple Mail Transfer Protocol (SMTP) server to send or receive emails. Complete the following to enable the printer to send an email with an Office 365 Outlook account from the control panel.

 **NOTE:** You must have an email address account with Office 365 Outlook to configure the settings in the EWS.

Configure the outgoing email server (SMTP) to send an email from an Office 365 Outlook account

1. Using the EWS top navigation tabs, click **Networking**.
2. In the left navigation pane, click **TCP/IP Settings**.
3. In the **TCP/IP Settings** area, click the **Network Identification** tab.
4. If DNS is required on the network, in the **TCP/IP Domain Suffix** area, verify that the DNS suffix for the email client being used is listed. DNS suffixes have this format: *companyname.com*, Gmail.com, etc.

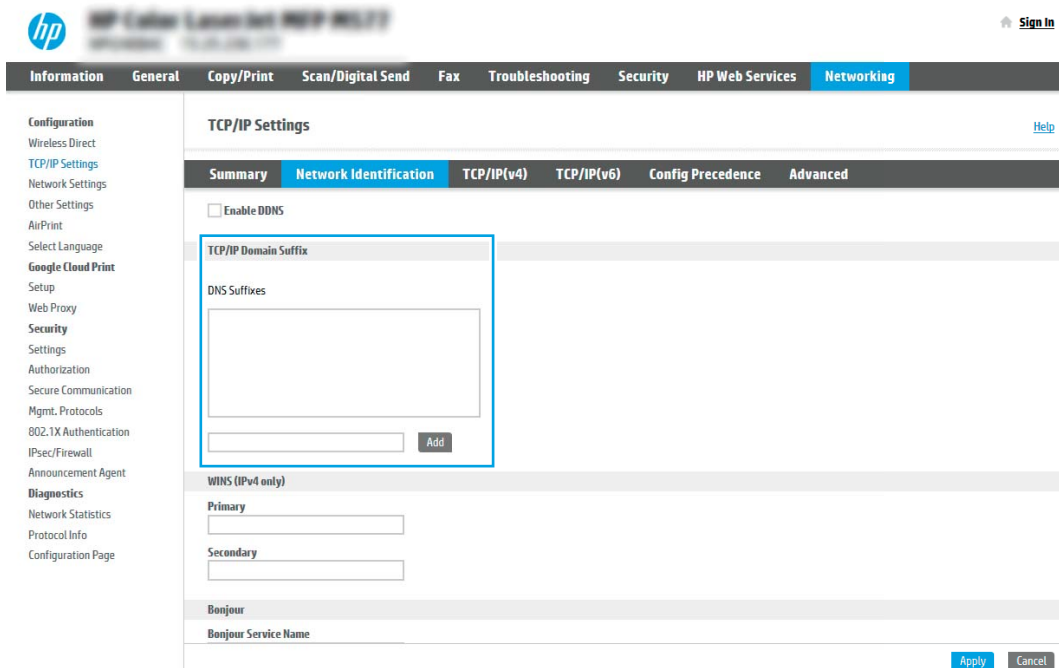

The screenshot shows the HP EWS interface for TCP/IP Settings. The 'Networking' tab is selected in the top navigation bar. The left navigation pane shows 'TCP/IP Settings' selected. The main content area is titled 'TCP/IP Settings' and has a sub-tab 'Network Identification' selected. Under 'Network Identification', there is a checkbox for 'Enable DDNS' which is unchecked. Below that is the 'TCP/IP Domain Suffix' section, which contains a 'DNS Suffixes' list box and an 'Add' button. The 'WINS (IPv4 only)' section has 'Primary' and 'Secondary' input fields. The 'Bonjour' section has a 'Bonjour Service Name' input field. 'Apply' and 'Cancel' buttons are at the bottom right.

 **NOTE:** If the Domain Name suffix is not set up, use the IP address.

5. Click **Apply**.
6. Click the **Scan/Digital Send** tab.
7. On the left navigation pane, click **Email Setup**.

- On the **Email Setup** page, select the **Enable Scan to Email** check box. If this check box is not available, the feature is unavailable at the printer control panel.

The screenshot shows the HP Email Setup interface. The top navigation bar includes 'Information', 'General', 'Copy/Print', 'Scan/Digital Send', 'Fax', 'Troubleshooting', 'Security', 'HP Web Services', and 'Networking'. The 'Scan/Digital Send' tab is active. On the left, a sidebar lists 'Email Setup' with sub-options: 'Default Job Options', 'Quick Sets', 'Scan to Network Folder', and 'Scan to USB Drive'. The main content area is titled 'Email Setup > Default Job Options'. It features a description: 'This feature allows users to scan documents and send them as email attachments to one or more email addresses.' Below this is a checkbox labeled 'Enable Scan to Email', which is checked. Further down, there is a section for 'Outgoing Email Servers (SMTP)' with a text input field for 'Click Add to configure a server' and buttons for 'Add...', 'Edit...', and 'Remove...'. The final section is 'Address and Message Field Control', which includes instructions and settings for 'From:', 'Subject:', and 'Message:' fields, each with a 'User editable' checkbox.

- In the **Outgoing Email Servers (SMTP)** area, click **Add** to start the SMTP wizard.
- In the **I know my SMTP server address or host name** field, type smtp.onoffice.com, and then click **Next**.
- On the **Set the basic information necessary to connect to the server** dialog, in the **Port Number** field, type **587**.

 **NOTE:** Some servers have problems sending or receiving emails that are larger than 5 megabytes (MB). These problems can be prevented by entering a number in **Split emails if larger than (MB)**.

- Select the **Enable SMTP SSL Protocol** check box, and then click **Next**.
- On the **Server Authentication Requirements** dialog, complete the following information:
 - Select **Server requires authentication**.
 - From the drop-down list, select **Always use these credentials**
 - In the **Username** field, type the Office 365 Outlook email address.
 - In the **Password** field, type the Office 365 Outlook account password, and then click **Next**.
- On the **Server Usage** dialog, choose the printer functions that will send email through this SMTP server, and then click the **Next** button.
- On the **Summary and Test** dialog, enter a valid email address in the **Send test email to:** field, and then click **Test**.
- Verify that all of the settings are correct, and then click **Finish** to complete the outgoing email server set up.

Set up Scan to Network Folder

- [Introduction](#)
- [Before you begin](#)
- [Step one: Access the HP Embedded Web Server](#)
- [Step two: Set up Scan to Network Folder](#)

Introduction

This document explains how to enable and configure the Scan to Network Folder function. The printer has a feature that enables it to scan a document and save it to a network folder. To use this scan feature, the printer must be connected to a network; however, the feature is not available until it has been configured. There are two methods for configuring Scan to Network Folder, the **Save to Network Folder Setup Wizard** for basic setup and **Save to Network Folder Setup** for advanced setup.

Before you begin



 **NOTE:** To set up the Scan to Network Folder feature, the printer must have an active network connection.

Administrators need the following items before beginning the configuration process.

- Administrative access to the printer
- The fully-qualified domain name (FQDN) (e.g., \\servername.us.companyname.net\scans) of the destination folder OR the IP address of the server (e.g., \\16.88.20.20\scans).

 **NOTE:** The use of the term "server" in this context refers to the computer where the shared folder resides.

Step one: Access the HP Embedded Web Server

1. From the Home screen on the printer control panel, touch the Information  icon, and then touch the Network  icon to display the IP address or host name.
2. Open a web browser, and in the address line, type the IP address or host name exactly as it displays on the printer control panel. Press the **Enter** key on the computer keyboard. The EWS opens.

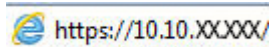

 **NOTE:** If the web browser displays a message indicating that accessing the website might not be safe, select the option to continue to the website. Accessing this website will not harm the computer.

The screenshot shows the HP Embedded Web Server (EWS) interface. At the top, there is a search bar and a 'Welcome Sign In' button. Below the search bar is a navigation menu with tabs: Information, General, Copy/Print, Scan/Digital Send, Fax, Troubleshooting, Security, HP Web Services, and Networking. The left sidebar contains a list of links: Device Status, Job Log, Configuration Page, Supplies Status Page, Event Log Page, Usage Page, Device Information, Control Panel Snapshot, Print, Printable Reports and Pages, and Open Source Licenses. The main content area is titled 'Device Status' and includes a 'Sleep mode on' indicator. Under 'Supplies', there are four cartridge status bars: Black Cartridge (Order 508A (CF360A)) at 90%, Cyan Cartridge (Order 508A (CF361A)) at 90%, Magenta Cartridge (Order 508A (CF363A)) at 90%, and Yellow Cartridge (Order 508A (CF362A)) at 90%. Below these are the Fuser Kit (Order 110V-B5L35A, 220V-B5L36A) at 100% and the Document Feeder Kit (Order B5L52A) at 100%. A note indicates 'Toner Collection Unit B5L37A: OK' and '* Estimated levels. Actual levels may vary.' with a 'Supplies Details' link. The 'Media' section contains a table:

Input/Output	Status	Capacity	Size	Type
Tray 1	Empty	100 sheets	Any Size	Any Type
Tray 2	OK	550 sheets	Letter (8.5x11)	Plain
Standard bin	OK	250 sheets	N/A	N/A

A 'Change Settings' link is located below the table.

Step two: Set up Scan to Network Folder

Method one: Use the Scan to Network Folder Wizard

This option opens the setup wizard that is in the HP Embedded Web Server (EWS) for the printer. The setup wizard includes the options for basic configuration.

1. Using the EWS top navigation tabs, click **Scan/Digital Send** tab.
2. In the left-navigation pane, click **Email and Scan to Network Folder Quick Setup Wizards**.
3. Click the **Save to Network Folder Quick Set Wizard** link.
4. On the **Add or Remove a Save to Network Folder Quick Set** dialog, click **Add**.

 **NOTE:** Quick Sets are short-cut jobs that can be accessed on the printer Home screen or within the Quick Sets application.

 **NOTE:** The Save to Network Folder feature can be minimally configured without creating a quick set. However, without the quick set, users must enter the destination folder information at the control panel for each scan job. A quick set is required to include Save to Network Folder metadata.

5. On the **Add Folder Quick Set** dialog, complete the following information:
 - a. In the **Quick Set Title** field, type a title.

 **NOTE:** Name the Quick Set something that users can understand quickly (e.g., "Scan and save to a folder").

- b. In the **Quick Set Description** field, type a description explaining what the Quick Set will save.
 - c. Click **Next**.
6. On the **Configure Destination Folder** dialog, complete the following information:

- a. In the **UNC Folder Path** field, type a folder path where the scan will go.
- The folder path can either be the fully-qualified domain name (FQDN) (e.g., \servername.us.companyname.net\scans) or the IP address of the server (e.g., \\16.88.20.20\scans). Be sure that the folder path (e.g., \scans) follows the FQDN or IP address.

 **NOTE:** The FQDN can be more reliable than the IP address. If the server gets its IP address via DHCP, the IP address can change. However, the connection with an IP address might be faster because the printer does not need to use DNS to find the destination server.

- b. From the **Authentication Settings** drop-down, select one of the following options:
- **Use credentials of user to connect after Sign In at the control panel**
 - **Always use these credentials**

 **NOTE:** If **Always use these credentials** is selected, a user name and password must be entered in the corresponding fields, and the printer's access to the folder must be verified by clicking **Verify Access**.

- c. In the **Windows Domain** field, type the Windows domain.

 **TIP:** To find the Windows domain in Windows 7, click **Start**, click **Control Panel**, and then click **System**.

To find the Windows domain in Windows 8, click **Search**, enter **System** in the search box, and then click **System**.

The domain is listed under **Computer name, domain, and workgroup settings**.

- d. Click **Next**.
7. On the **Configure File Scan Settings** dialog, set the default scanning preferences for the Quick Set, and then click **Next**.
8. Review the **Summary** dialog, and then click **Finish**.

Method two: Use Scan to Network Folder Setup

This option enables advanced configuration of the Save to Network Folder feature using the HP Embedded Web Server (EWS) for the printer.

Step one: Begin the configuration

1. Click the **Scan/Digital Send** tab.
2. On the left navigation menu, click the **Scan to Network Folder Setup** link.

Step two: Configure the Scan to Network Folder settings

1. On the **Scan to Network Folder Setup** page, select the **Enable Scan to Network Folder** check box. If this box is not selected, the feature is unavailable at the printer control panel.
2. In the Scan to Network Folder area of the left navigation pane, click **Quick Sets**. Click **Add** to open the **Quick Sets Setup** dialog.

 **NOTE:** Quick Sets are short-cut jobs that can be accessed on the printer Home screen or within the Quick Sets application.

 **NOTE:** The **Scan to Network Folder** feature can be minimally configured without creating a quick set. However, without the quick set, users must enter the destination folder information at the control panel for each scan job. A quick set is required to include Scan to Network Folder metadata.

Complete all of the settings in the Quick Set Setup to fully configure the Scan to Network Folder feature.

Dialog one: Set the Quick Set name, description, and options for user interaction at the control panel

Use the **Set the button location for the Quick Set and options for user interaction at the control panel** dialog to configure where the **Quick Set** button will display on the printer control panel and to configure the level of user interaction at the printer control panel.

1. In the **Quick Set Name** field, type a title.

 **NOTE:** Name the Quick Set something that users can understand quickly (e.g., "Scan and save to a folder").

2. In the **Quick Set Description** field, type a description explaining what the Quick Set will save.
3. From the **Quick Set Start Option** list, select one of the following options:

- Option one: **Enter application, then user presses Start**
- Option two: **Start instantly upon selection**

Select one of the following prompt options :

- **Prompt for original sides**
- **Prompt for additional pages**
- **Require Preview**

 **NOTE:** If **Start instantly upon selection** is selected, the destination folder must be entered in the next step.

4. Click **Next**.

Dialog two: Folder Settings

Use the **Folder Settings** dialog to configure the types of folders the printer sends scanned documents to.

There are two types of destination folders to select from:

- Shared folders or FTP folders
- Personal shared folders

There are two types of folder permissions to select from:

- Read and write access
- Write access only

The following information describes how to configure the folder settings.

The screenshot shows the HP Web Services interface for 'Quick Sets Setup'. The top navigation bar includes 'Information', 'General', 'Copy/Print', 'Scan/Digital Send', 'Fax', 'Troubleshooting', 'Security', 'HP Web Services', and 'Networking'. The left sidebar lists various setup options, with 'Scan to Network Folder' expanded to show 'Default Job Options', 'Quick Sets', and 'Folder Quick Setup Wizards'. The main content area is titled 'Quick Sets Setup' and contains 'Folder Settings'. A text box explains that standard shared folders are simple UNC paths. Three radio button options are available: 'Save to shared folders or FTP folders' (selected), 'Save to a personal shared folder', and 'Send only to folders with read and write access'. The selected option includes a text input field for a destination, 'Add...', 'Edit...', and 'Remove...' buttons, and a checked checkbox for 'Verify folder access prior to job start'. The 'Send only to folders with read and write access' option has a sub-option 'Allow sending to folders with write access only'. At the bottom right, there are 'Previous', 'Next', 'Finish', and 'Cancel' buttons.

Configure the destination folder for scanned documents

Option 1: Shared folders or FTP folders

To save scanned documents to a standard shared folder or an FTP folder, complete the following steps:

1. If it is not already selected, select **Save to shared folders or FTP folders**.
2. Click **Add...**. The **Add Network Folder Path** dialog opens.
3. On the **Add Network Folder Path** dialog, select one of the following options:
 - Option one: **Save to a standard shared network folder**



- Email Setup
 - Default Job Options
 - Quick Sets
- Scan to Network Folder
 - Default Job Options
 - Quick Sets
- Scan to USB Drive
- Contacts
- Email and Scan to Network Folder Quick Setup Wizards
- Digital Sending Software Setup

Quick Sets Setup

Add Network Folder Path

 Save to a standard shared network folder

UNC Folder Path:

(\path\path)

Custom Subfolder:

Appends a custom subfolder at end of the folder path.

 Restrict subfolder access to user

Folder Path Preview:

Update Preview

Some Custom Subfolder values will be updated only when the Quick Set is used.

Authentication Settings:

Use credentials of user to connect after Sign In at the control panel

Windows Domain:

 Save to an FTP Server

A Workstation or Server that has a File Transfer Protocol (FTP) service installed and configured.

OK Cancel



NOTE: For more information about creating shared network folders see [Set up a shared folder](#) (c04431534).

1. If it is not already selected, select **Save to a standard shared network folder**.
2. In the **UNC Folder Path** field, type a folder path.

The folder path can either be the fully-qualified domain name (FQDN) (e.g., \servername.us.companyname.net\scans) or the IP address of the server (e.g., \16.88.20.20\scans). Be sure that the folder path (e.g., \scans) follows the FQDN or IP address.



NOTE: The FQDN can be more reliable than the IP address. If the server gets its IP address via DHCP, the IP address can change. However, the connection with an IP address might be faster because the printer does not need to use DNS to find the destination server.

3. To automatically create a subfolder for scanned documents in the destination folder, select a format for the subfolder name from the **Custom Subfolder** list.

To restrict the subfolder access to the user who creates the scan job, select **Restrict subfolder access to user**.

4. To view the complete folder path for scanned documents, click **Update Preview**.
5. From the **Authentication Settings** list, select one of the following options:
 - Use credentials of user to connect after Sign In at the control panel
 - Always use these credentials



NOTE: If **Always use these credentials** is selected, a user name and password must be entered in the corresponding fields.

6. In the **Windows Domain** field, type the Windows domain.

 **NOTE:** To find the Windows domain in Windows 7, click **Start**, click **Control Panel**, and then click **System**.

To find the Windows domain in Windows 8, click **Search**, enter **System** in the search box, and then click **System**.

The domain is listed under **Computer name, domain, and workgroup settings**.

 **NOTE:** If a shared folder is set to be accessed by everyone, values for a workgroup name (default is “Workgroup”), a user name and password must be entered in the corresponding fields. However, if the folder is within a particular user’s folders and not Public, the user name and password of that user must be used.

 **NOTE:** An IP address might be necessary instead of a computer name. Many home routers do not handle computer names well, and there is no Domain Name Server (DNS). In this case, it is best to set up a static IP address on the shared PC to alleviate the problem of DHCP assigning a new IP address. On a typical home router, this is done by setting a static IP address that is on the same subnet, but outside the DHCP address range.

7. Click **OK**.

- Option two: **Save to an FTP Server**

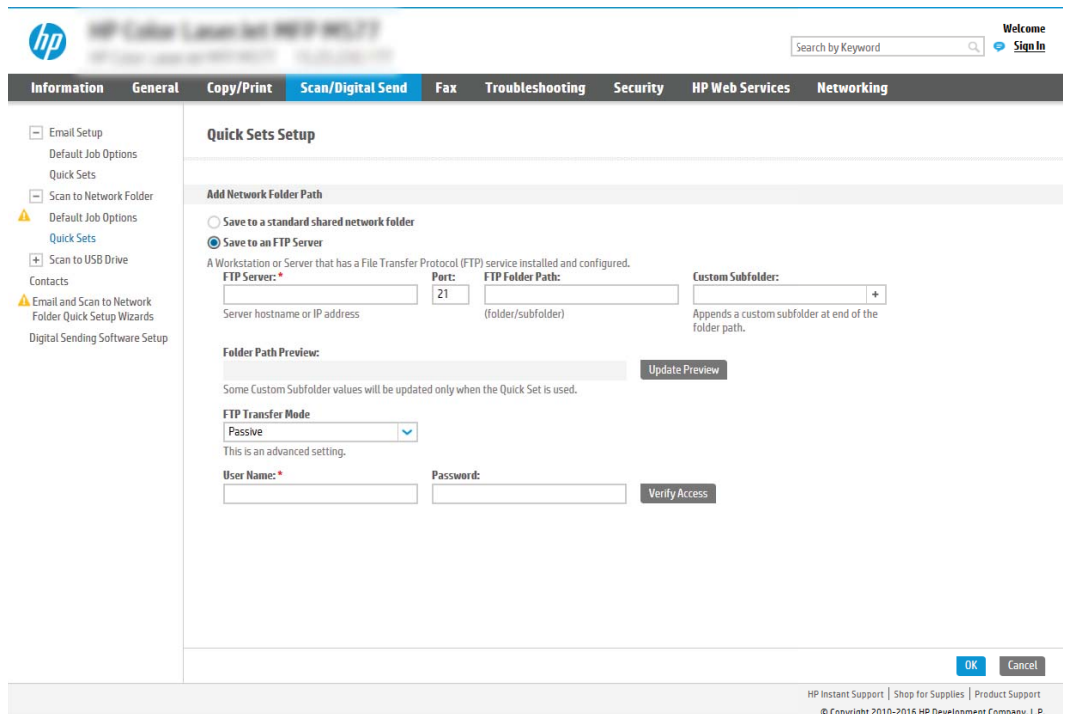

The screenshot shows the HP EWS 'Quick Sets Setup' page. The 'Scan/Digital Send' tab is active. Under 'Add Network Folder Path', the 'Save to an FTP Server' option is selected. The form includes fields for 'FTP Server' (Server hostname or IP address), 'Port' (set to 21), 'FTP Folder Path' (folder/subfolder), and 'Custom Subfolder'. There is a 'Folder Path Preview' section with an 'Update Preview' button. The 'FTP Transfer Mode' is set to 'Passive'. There are also 'User Name' and 'Password' fields with a 'Verify Access' button. The page footer contains 'HP Instant Support | Shop for Supplies | Product Support' and '© Copyright 2010-2016 HP Development Company, L.P.'

 **NOTE:** If an FTP site is outside the firewall, a proxy server must be specified under the network settings. These settings are located in the **EWS Networking** tab, under the **Advanced** options.

1. Select **Save to an FTP Server**.
2. In the **FTP Server** field, type the FTP server name or IP address.
3. In the **Port** field, type the port number.

 **NOTE:** In most cases, the default port number does not need to be changed.

4. To automatically create a subfolder for scanned documents in the destination folder, select a format for the subfolder name from the **Custom Subfolder** list.
5. To view the complete folder path for scanned documents, click **Update Preview**.
6. From the **FTP Transfer Mode** list, select one of the following options:
 - **Passive**
 - **Active**
7. In the **Username** field, type the user name.
8. In the **Password field**, type the password.
9. Click **Verify Access** to confirm the destination can be accessed.
10. Click **OK**.

Option 2: Personal shared folders

To save scanned documents to a personal shared folder, complete the following steps:

 **NOTE:** This option is used in domain environments where the administrator configures a shared folder for each user. If the Save to a personal shared folder feature is configured, users will be required to sign in at the printer control panel using Windows credentials or LDAP authentication.

1. Select **Save to a personal shared folder**.
2. In the **Retrieve the device user's home folder using this attribute** field, type the user's home folder in the Microsoft Active Directory.

 **NOTE:** Verify that the user knows where this home folder is located on the network.

3. To add a user name subfolder at the end of the folder path, select **Create subfolder based on user name**.
To restrict the subfolder access to the user who creates the scan job, select **Restrict subfolder access to user**.

Select the destination folder permissions

Option 1: Read and write access

To send scanned documents to a folder configured for read and write access, complete the following steps:

 **NOTE:** **Send only to folders with read and write access** supports folder verification and job notification.

1. If it is not already selected, select **Send only to folders with read and write access**.
2. To require the printer to verify folder access before starting a scan job, select **Verify folder access prior to job start**.

 **NOTE:** Scan jobs can complete more quickly if **Verify folder access prior to job start** is not selected; however, if the folder is unavailable, the scan job will fail.

3. Click **Next**.

Option 2: Write access only

To send scanned documents to a folder configured for write access only, complete the following steps:

 **NOTE:** **Allow sending to folders with write access only** does not support folder verification or job notification.

 **NOTE:** If this option is selected, the printer cannot increment the scan filename. It sends the same filename for all scans.

Select a time-related filename prefix or suffix for the scan filename, so that each scan is saved as a unique file, and does not overwrite a previous file. This filename is determined by the information in the File Settings dialog in the Quick Set Wizard.

1. Select **Allow sending to folders with write access only**.
2. Click **Next**.

Dialog three: Notification settings

▲ On the **Notification** dialog, complete one of the following tasks:

 **NOTE:** In order to send notification emails, the printer must be set up to use an SMTP server for sending email jobs. For more information about setting up the SMTP server for sending emails see [Set up Scan to Email](#) (c04017973).

- Option one: **Do not notify**
 1. Select **Do not notify**.
 2. To prompt the user to review their notification settings, select **Prompt user prior to job start**, and then click **Next**.
- Option two: **Notify when job completes**
 1. Select **Notify when job completes**.
 2. Select the method for delivering the notification from the **Method Used to Deliver Notification** list.

If the method of notification selected is **Email**, type the email address in the **Notification Email Address** field.
 3. To include a thumbnail of the first scanned page in the notification, select **Include Thumbnail**.
 4. To prompt the user to review their notification settings, select **Prompt user prior to job start**, and then click **Next**.
- Option three: **Notify only if job fails**
 1. Select **Notify only if job fails**.
 2. Select the method for delivering the notification from the **Method Used to Deliver Notification** list.

If the method of notification selected is **Email**, type the email address in the **Notification Email Address** field.
 3. To include a thumbnail of the first scanned page in the notification, select **Include Thumbnail**.
 4. To prompt the user to review their notification settings, select **Prompt user prior to job start**, and then click **Next**.

Dialog four: Scan Settings

On the **Scan Settings** dialog, set the default scanning preferences for the Quick Set, and then click **Next**.

Scan settings:

Feature	Description
Original Size	Select the page size of the original document.
Original Sides	Select whether the original document is single-sided or double-sided.
Optimize Text/Picture	Select to optimize for the output of a particular type of content.
Content Orientation	Select the way the content of the original document is placed on the page: Portrait or Landscape .
Background Cleanup	Select a value to remove faint images from the background or to remove a light background color.
Darkness	Select a value to adjust the darkness of the file.
Contrast	Select a value to adjust the contrast of the file.
Sharpness	Select a value to adjust the sharpness of the file.
Image Preview	Select whether to require or make optional a displayed preview of the job or to disable a preview.
Cropping Options	Select whether or not to allow a job to be cropped and the type of cropping option.
Erase Edges	Select this setting to specify the width of edge margins to be erased, in either inches or millimeters, for the front side and back side of a job.

Dialog five: File Settings

On the **File Settings** dialog, set the default file settings for the Quick Set, and then click **Next**.

File settings:

Feature	Description
File Name Prefix	Set the default file name prefix used for files saved to a network folder.
File Name	Default file name for the file to be saved. Select the User editable check box to make this setting editable at the printer control panel.
File Name Suffix	Set the default file name suffix used for files saved to a network folder.
File Name Preview	Enter a file name, and then click the Update Preview button.
File Numbering Format	Select a file name format for when the job is divided into multiple files.
Add numbering when job has just one file (ex. _1-1)	Select this setting to add numbering to a file name when the job is only one file instead of multiple files.
File Type	Select the file format for the saved file. Select the User editable check box to make this setting editable at the printer control panel.
High Compression (smaller file)	Select this setting to compress the scanned file, which reduces the file size. However, the scanning process for a High compression file might take longer than for a Normal compression file.
PDF encryption	If the file type is PDF, then this option encrypts the output PDF file. A password must be specified as part of the encryption. The same password must be used to open the file. The user will be prompted to enter a password prior to scanning their job if one has not been set prior to pressing start.

Feature	Description
Resolution	Set the resolution for the file. Higher resolution images have more dots per inch (dpi), so they show more detail. Lower resolution images have fewer dots per inch and show less detail, but the file size is smaller.
Quality and File Size	Select the quality for the file. Higher-quality images require a larger file size than lower-quality images, and they take more time to send.
Color/Black	Specify whether copies are to be printed in color, black and gray, or black only.
Suppress blank pages	If the Suppress blank pages option is enabled, blank pages will be ignored.
Meta Data File Format	Use the drop-down list to select the file format for meta-data information.
Create Multiple Files	Select this setting to scan pages into separate files based on a predetermined maximum number of pages per file.

Dialog six: Summary

On the **Summary** dialog, review the **Summary** dialog, and then click **Finish**.

Step three: Complete the configuration

1. In the left-navigation pane, click **Scan to Network Folder**.
2. On the **Scan to Network Folder** page, review the selected settings, and then click **Apply** to complete the setup.



Set up Scan to USB Drive

- [Introduction](#)
- [Step one: Access the HP Embedded Web Server](#)
- [Step two: Enable Scan to USB Drive](#)
- [Step three: Configure the Quick Sets \(optional\)](#)
- [Default scan settings for Scan to USB Drive setup](#)
- [Default file settings for Scan to USB Drive setup](#)

Introduction

The printer has a feature that enables it to scan a document and save it to a USB flash drive. The feature is not available until it has been configured through the HP Embedded Web Server (EWS).

Step one: Access the HP Embedded Web Server

1. From the Home screen on the printer control panel, touch the Information  icon, and then touch the Network  icon to display the IP address or host name.
2. Open a web browser, and in the address line, type the IP address or host name exactly as it displays on the printer control panel. Press the **Enter** key on the computer keyboard. The EWS opens.

 <https://10.10.XXXXX/>

 **NOTE:** If the web browser displays a message indicating that accessing the website might not be safe, select the option to continue to the website. Accessing this website will not harm the computer.

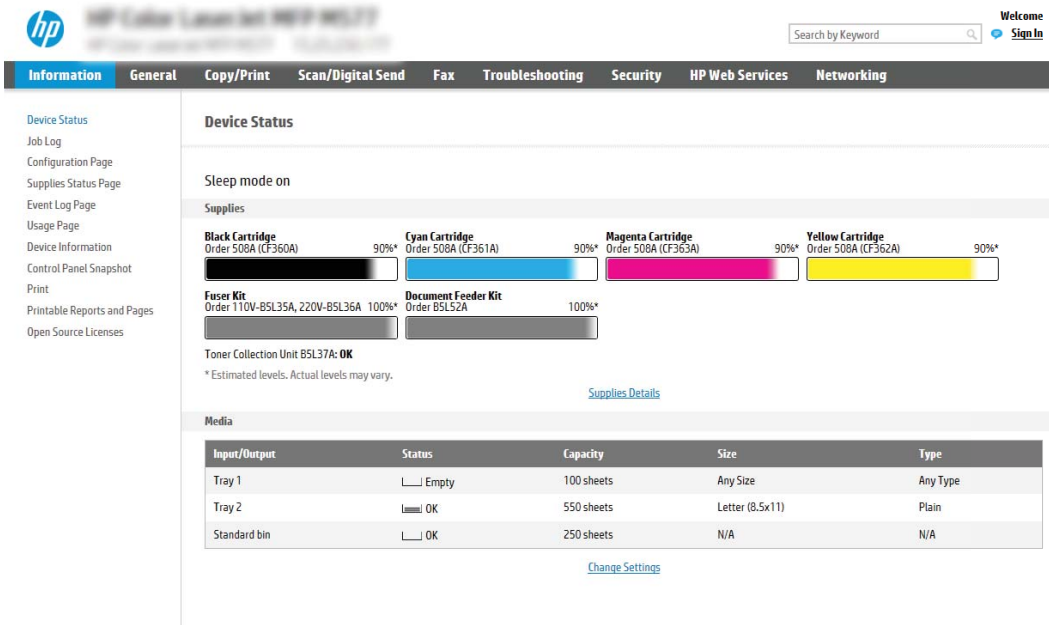

The screenshot shows the HP Embedded Web Server (EWS) interface. The top navigation bar includes tabs for Information, General, Copy/Print, Scan/Digital Send, Fax, Troubleshooting, Security, HP Web Services, and Networking. The left sidebar lists various status and configuration pages. The main content area displays the 'Device Status' page, which includes a 'Supplies' section with progress bars for Black, Cyan, Magenta, and Yellow cartridges, as well as Fuser Kit and Document Feeder Kit. Below this is a 'Media' section with a table showing the status of input/output trays and bins.

Input/Output	Status	Capacity	Size	Type
Tray 1	Empty	100 sheets	Any Size	Any Type
Tray 2	OK	550 sheets	Letter (8.5x11)	Plain
Standard bin	OK	250 sheets	N/A	N/A

Step two: Enable Scan to USB Drive

1. Select the **Security** tab.
2. Scroll to **Hardware Ports** and make sure that **Enable Host USB plug and play** is enabled.
3. Select the **Scan/Digital Send** tab.
4. Select the **Enable Scan to USB Drive** check box.
5. Click **Apply** at the bottom of the page.



NOTE: Most devices ship with Hard disk drives (HDDs) already installed. In some cases, additional storage devices can be added via USB. Verify whether the Scan to USB Drive feature needs to be expanded to USB and Hard drive

Step three: Configure the Quick Sets (optional)



NOTE: Quick Sets are short-cut jobs that can be accessed on the printer Home screen or within the Quick Sets application.

1. In the **Scan to USB Drive** area of the left navigation pane, click **Quick Sets**.
2. Select one of the following options:
 - Select an existing Quick Set under Quick Sets Application in the table.
 - OR-
 - Click **Add** to start the Quick Set Wizard.
3. If you selected **Add**, the **Quick Sets Setup** page opens. Complete the following information, and then click **Next**.
 - **Quick Set Name:** Enter a title for the new Quick Set.
 - **Quick Set Description:** Enter a description of the Quick Set.
 - **Quick Set Start Option:** To set how the Quick Set starts, click either **Enter application, then user presses Start** or **Start instantly when selected from the Home Screen**.
4. Select a default location where scanned files are saved on USB storage devices inserted into the USB port on the control panel, and then click **Next**. The default location options are:
 - **Save at root directory of the USB storage device**
 - **Create or place in this folder on the USB Storage Device** — The path to the folder on the USB storage device must be specified when using this file location option. A backslash \ must be used to separate folder\subfolder names in the path.
5. Select an option from the **Condition on Which to Notify:** drop-down list, and then click **Next**.

This setting determines if, or how, users are notified when a Scan To USB Drive Quick Set job completes or fails. The options for the **Condition on Which to Notify:** setting are:

- Do not notify
 - Notify when job completes
 - Notify only if job fails
6. Choose the **Scan Settings** for the Quick Set, and then click **Next**.

 **NOTE:** For more information on the available scan settings, see “Default scan settings for Scan to USB Drive setup.”

7. Choose the **File Settings** for the Quick Set, and then click **Next**.

 **NOTE:** For more information on the available file settings, see “Default file settings for Scan to USB Drive setup”

8. Review the summary of settings, and then click **Finish** to save the Quick Set, or click **Previous** to edit the settings.

Default scan settings for Scan to USB Drive setup

Table 6-1 Scan settings for Scan to USB Drive Setup:

Feature	Description
Original Size	Select the page size of the original document.
Original Sides	Select whether the original document is single-sided or double-sided.
Optimize Text/Picture	Select to optimize for the output of a particular type of content.
Content Orientation	Select the way the content of the original document is placed on the page: Portrait or Landscape .
Background Cleanup	Select a value to remove faint images from the background or to remove a light background color.
Darkness	Select a value to adjust the darkness of the file.
Contrast	Select a value to adjust the contrast of the file.
Sharpness	Select a value to adjust the sharpness of the file.
Image Preview	Select whether to require or make optional a displayed preview of the job or to disable a preview.
Cropping Options	Select whether or not to allow a job to be cropped and the type of cropping option.
Erase Edges	Select this setting to specify the width of edge margins to be erased, in either inches or millimeters, for the front side and back side of a job.

Default file settings for Scan to USB Drive setup

Table 6-2 File settings for Scan to USB Drive Setup:

Option name	Description
File Name Prefix	Set the default file name prefix for the file to be saved.

Table 6-2 File settings for Scan to USB Drive Setup: (continued)

Option name	Description
File Name	Set the default file name for the file to be saved. Select the User editable check box to make this setting editable at the printer control panel.
File Name Suffix	Set the default file name suffix for the file to be saved. Duplicate filename suffix default [filename]_YYYYMMDDT
File Name Preview	Enter a file name, and then click the Update Preview button.
File Numbering Format	Select a file name format for when the job is divided into multiple files.
Add numbering when job has just one file (ex. _1-1)	Select this setting to add numbering to a file name when the job is only one file instead of multiple files.
File Type	Select the file format for the saved file. Select the User editable check box to make this setting editable at the printer control panel.
High Compression (smaller file)	Select this setting to compress the scanned file, which reduces the file size. However, the scanning process for a High compression file might take longer than for a Normal compression file.
PDF encryption	If the file type is PDF, then this option encrypts the output PDF file. A password must be specified as part of the encryption. The same password must be used to open the file. The user will be prompted to enter a password prior to scanning their job if one has not been set prior to pressing start.
Resolution	Set the resolution for the file. Higher resolution images have more dots per inch (dpi), so they show more detail. Lower resolution images have fewer dots per inch and show less detail, but the file size is smaller.
Quality and File Size	Select the quality for the file. Higher-quality images require a larger file size than lower-quality images, and they take more time to send.
Color/Black	Specify whether the file to be saved is color, black and gray, or black only.
Suppress blank pages	If the Suppress blank pages option is enabled, blank pages will be ignored.
Create Multiple Files	Select this setting to scan pages into separate files based on a predetermined maximum number of pages per file.

Set up Scan to SharePoint® (Flow models only)

- [Introduction](#)
- [Before you begin](#)
- [Step one: Access the HP Embedded Web Server \(EWS\)](#)
- [Step two: Enable Scan to SharePoint® and create a Scan to SharePoint Quick Set](#)
- [Quick set scan settings and options for Scan to SharePoint®](#)

Introduction

Use Scan to SharePoint® to scan documents directly to a Microsoft® SharePoint site. This feature eliminates the need to scan the documents to a network folder, USB flash drive, or email message, and then manually upload the files to the SharePoint site.

Scan to SharePoint® supports all scanning options, including the ability to scan documents as images or use the OCR features to create text files or searchable PDFs.

The feature is disabled by default. Enable Scan to SharePoint® in the HP Embedded Web Server (EWS).





NOTE: The Scan to SharePoint® feature is only available on workflow-equipped printers.

Before you begin

Before this procedure can be completed, the destination folder that the scanned files will be saved to must exist on the SharePoint site, and write access must be enabled to the destination folder. Scan to SharePoint® is disabled by default.

Step one: Access the HP Embedded Web Server (EWS)

1. From the Home screen on the printer control panel, touch the Information  icon, and then touch the Network  icon to display the IP address or host name.
2. Open a web browser, and in the address line, type the IP address or host name exactly as it displays on the printer control panel. Press the [Enter](#) key on the computer keyboard. The EWS opens.

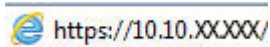
A screenshot of a web browser address bar showing the URL <https://10.10.XX.XXX/>. The address bar has a blue address bar icon on the left and a blue address bar icon on the right.

NOTE: If the web browser displays a message indicating that accessing the website might not be safe, select the option to continue to the website. Accessing this website will not harm the computer.

The screenshot displays the HP Web Services interface for a printer. The top navigation bar includes tabs for Information, General, Copy/Print, Scan/Digital Send, Fax, Troubleshooting, Security, HP Web Services, and Networking. A search bar and a 'Welcome Sign In' link are also present. The left sidebar contains a list of navigation options: Device Status, Job Log, Configuration Page, Supplies Status Page, Event Log Page, Usage Page, Device Information, Control Panel Snapshot, Print, Printable Reports and Pages, and Open Source Licenses. The main content area is titled 'Device Status' and includes a 'Sleep mode on' section. Below this is a 'Supplies' section with progress bars for Black Cartridge (Order 508A, CF360A, 90%*), Cyan Cartridge (Order 508A, CF361A, 90%*), Magenta Cartridge (Order 508A, CF362A, 90%*), and Yellow Cartridge (Order 508A, CF362A, 90%*). It also shows Fuser Kit (Order 110V-B5L35A, 220V-B5L36A, 100%*) and Document Feeder Kit (Order B5L52A, 100%*). A note indicates 'Toner Collection Unit B5L37A: OK' and '* Estimated levels. Actual levels may vary.' with a 'Supplies Details' link. The 'Media' section contains a table:

Input/Output	Status	Capacity	Size	Type
Tray 1	Empty	100 sheets	Any Size	Any Type
Tray 2	OK	550 sheets	Letter (8.5x11)	Plain
Standard bin	OK	250 sheets	N/A	N/A

A 'Change Settings' link is located below the table.

Step two: Enable Scan to SharePoint® and create a Scan to SharePoint Quick Set

Follow these steps to enable the feature **Scan to SharePoint** feature and create a Scan to SharePoint Quick Set:

1. Using the top navigation tabs, click **Scan/Digital Send**.
2. In the left navigation pane, click **Scan to SharePoint®**.

 **NOTE:** Quick Sets are short-cut jobs that can be accessed on the printer Home screen or within the **Quick Sets** application.

3. Select the **Enable Scan to SharePoint®** check box, and then click **Add...**
4. Enter a **Quick Set Name** (for example, "Scan to SharePoint") and a **Quick Set Description**.
5. Select a **Quick Set Start Option** to determine what occurs after selecting a Quick Set on the printer control panel, and then click the **Next** button.
6. Use the following steps to add the path to the SharePoint folder.
 - a. Click **Add** on the **SharePoint® Destination** page to open the **Add SharePoint® Path** page.
 - b. Open another browser window, navigate to the SharePoint folder to use, and then copy the folder path for the SharePoint folder from that browser window.
 - c. Paste the SharePoint folder path into the **SharePoint® Path:** field.
 - d. By default, the printer overwrites an existing file that has the same file name as the new file. Clear **Overwrite existing files** so that a new file with the same name as an existing file is given an updated time/date stamp.
 - e. Select an option from the **Authentication Settings** drop-down menu. Select whether it is necessary to sign in to the SharePoint site with credentials, or store the credentials within the Quick Set.

 **NOTE:** Use credentials of user to connect after **Sign In at the control panel** is selected in the **Authentication Settings** drop-down menu, the logged-in user must have permissions to write to the specified SharePoint site.

 **NOTE:** For security purposes, the printer does not display credentials entered in the Quick Set Wizard.

- f. Click **OK** to complete the SharePoint path setup and navigate back to the **SharePoint Destination Settings** page.
7. Select **Verify folder access prior to job start** to ensure that the SharePoint folder specified as the destination folder is accessible each time the Quick Set is used. If this option is not selected, jobs can be saved to the SharePoint folder more quickly. However, if this option is not selected *and* the SharePoint folder is inaccessible the job will fail.
8. Click **Next**.
9. Set a **Condition on Which to Notify**: on the **Notification** page. This setting configures the Quick Set to either not notify, or to send email messages or print a summary page if a job either completes successfully or fails. Select one of the following options from the **Condition on Which to Notify**: drop-down menu:
 - Select **Do not notify** for the Quick Set to not perform any notification action when a job completes successfully or fails.
 - Select **Notify when job completes** to for the Quick Set to send a notification when a job completes successfully.
 - Select **Notify only if job fails** to for the Quick Set to send a notification only when a job fails.

Selecting either **Notify when job completes** or **Notify only if job fails** requires the **Method Used to Deliver Notification**: to be set. Select from the following options:

- **Email**: Use this option to send an email when the selected notification condition occurs. This option requires a valid email address in the **Notification Email Address**: field.

 **NOTE:** To use the email notification feature, first configure the email feature on the printer.

- **Print**: Use this option to print the notification when the selected notification condition occurs.

 **NOTE:** Select **Include Thumbnail** for either notification option to include a thumbnail image of the first page of the scanned page of the job.

10. Click **Next**.
11. Select options from the **Scan Settings** page, and then click **Next**. For more information, see the table “Scan settings for Scan to SharePoint®.”
12. Select options from the **File Settings** page, and then click **Next**. For more information, see the table “File settings for Scan to SharePoint®.”
13. Review the summary of settings, and then click the **Finish** button to save the Quick Set, or click the **Previous** button to edit the settings.

Quick set scan settings and options for Scan to SharePoint®

The following tables list the settings and options available in the Quick Set Wizard when adding, editing, or copying a Scan to SharePoint® Quick Set.

Table 6-3 Scan settings for Scan to SharePoint®

Feature	Description
Original Size	Select the page size of the original document.
Original Sides	Select whether the original document is single-sided or double-sided.
Optimize Text/Picture	Select to optimize for the output of a particular type of content.
Content Orientation	Select the way the content of the original document is placed on the page: Portrait or Landscape .
Background Cleanup	Select a value to remove faint images from the background or to remove a light background color.
Darkness	Select a value to adjust the darkness of the file.
Contrast	Select a value to adjust the contrast of the file.
Sharpness	Select a value to adjust the sharpness of the file.
Image Preview	Select whether to require or make optional a displayed preview of the job or to disable a preview.
Cropping Options	Select whether or not to allow a job to be cropped and the type of cropping option.
Erase Edges	Select this setting to specify the width of edge margins to be erased, in either inches or millimeters, for the front side and back side of a job.

Table 6-4 File settings for Scan to SharePoint

Feature	Description
File Name Prefix	Set the default file name prefix used for the file to be saved.
File Name	Default file name for the file to be saved. Select the User editable check box to make this setting editable at the printer control panel.
File Name Suffix	Set the default file name suffix used for the file to be saved. Duplicate filename suffix default [filename]_YYYYMMDDT
File Name Preview	Enter a file name, and then click the Update Preview button.
File Numbering Format	Select a file name format for when the job is divided into multiple files.
Add numbering when job has just one file (ex. _1-1)	Select this setting to add numbering to a file name when the job is only one file instead of multiple files.
File Type	Select the file format for the saved file. Select the User editable check box to make this setting editable at the printer control panel.
High Compression (smaller file)	Select this setting to compress the scanned file, which reduces the file size. However, the scanning process for a High compression file might take longer than for a Normal compression file.
PDF encryption	If the file type is PDF, then this option encrypts the output PDF file. A password must be specified as part of the encryption. The same password must be used to open the file. The user will be prompted to enter a password prior to scanning their job if one has not been set prior to pressing start.
Resolution	Set the resolution for the file. Higher resolution images have more dots per inch (dpi), so they show more detail. Lower resolution images have fewer dots per inch and show less detail, but the file size is smaller.
Quality and File Size	Select the quality for the file. Higher-quality images require a larger file size than lower-quality images, and they take more time to send.

Table 6-4 File settings for Scan to SharePoint (continued)

Feature	Description
Color/Black	Specify whether copies are to be printed in color, black and gray, or black only
Suppress blank pages	If the Suppress blank pages option is enabled, blank pages will be ignored.
Create Multiple Files	Select this setting to scan pages into separate files based on a predetermined maximum number of pages per file.

Scan to email

Introduction

The printer has a feature that enables it to scan a document and send it to one or more email addresses.

 **NOTE:** Before you can scan to email, your printer administrator or IT department must use the HP Embedded Web Server to enable the feature and set it up.

Scan to email

1. Place the document face-down on the scanner glass, or place it face-up in the document feeder and adjust the paper guides to fit the size of the document.
2. From the Home screen on the printer control panel, select **Scan**, and then select **Scan to Email**.

 **NOTE:** If prompted, type your user name and password.

3. Touch the **To** field to open a keyboard.



 **NOTE:** If you are signed in to the printer, your user name or other default information might appear in the **From** field. If so, you might not be able to change it.

4. Specify the recipients by using one of these methods:

Enter addresses manually

- ▲ Enter the address in the **To** field. To send to multiple addresses, separate the addresses with a semicolon, or select the Enter  button on the touchscreen keyboard after typing each address.

Enter addresses from the Contacts list

- a. Select the Contacts  button that is next to the **To** field to open the **Contacts** screen.
 - b. Select the appropriate contact list.
 - c. Select a name or names from the list of contacts to add the name to the recipients list, and then select **Add**.
5. Complete the **Subject**, **File Name**, and **Message** fields by touching the field and using the touchscreen keyboard to enter information. Select the Close  button whenever you need to close the keyboard.
 6. To load a Quick Set, select **Load**, select the Quick Set, and then select **Load** under the **Quick Sets** list.

 **NOTE:** **Quick Sets** are predefined settings for various types of output, such as **Text**, **Photograph**, and **High Quality**. You can select a Quick Set to view the description.

7. To configure settings, such as **File Type and Resolution**, **Original Sides**, and **Content Orientation**, select **Options** in the lower left corner, and then select the settings from the **Options** menus. Select **Done** if prompted.
8. Optional Preview: Touch the right pane of the screen to preview the document. You can use the **Expand** and **Collapse** buttons on the left side of the preview pane to expand and collapse the preview screen.

Expand button



Collapse button



Use the buttons on the right of the screen to adjust the preview options and to rearrange, rotate, insert, or remove pages.



Toggle between the two-page view and the thumbnail view. More options are available in the thumbnail view than in the two-page view.



Zoom in or out on the selected page.

NOTE: Select only one page at a time to use these buttons.



Rotate the page 180 degrees.

NOTE: This button is available only in the thumbnail view.



Delete the selected pages.

NOTE: This button is available only in the thumbnail view.



Rearrange the pages within the document. Select one or more pages and move them to the left or right.

NOTE: These buttons are available only in the thumbnail view.



Add a page to the document. The printer prompts you to scan additional pages.



Clear the changes made in the preview and start over.

9. When the document is ready, select [Send](#) to email it.



NOTE: The printer might prompt you to add the email address to the contact list.

Scan to network folder

Introduction

The printer can scan a file and save it in a shared folder on the network.

 **NOTE:** Before you can scan to a network folder, your printer administrator or IT department must use the HP Embedded Web Server to enable the feature and configure the shared folders.

Scan to network folder

 **NOTE:** You might be required to sign in to the printer to use this feature.

1. Place the document face-down on the scanner glass, or place it face-up in the document feeder and adjust the paper guides to fit the size of the document.
2. From the Home screen on the printer control panel, select [Scan](#), and then select [Scan to Network Folder](#).
3. Specify a folder destination. Folder options must first be configured by the printer administrator.
 - To select a folder location that the administrator already set up, select [Load](#) under [Quick Sets and Defaults](#), select the folder, and then select [Load](#).
 - To specify a new folder location, touch the [Folder Paths](#) field to open a touchscreen keyboard, type the path to the folder, and then select the Enter  button. Enter user credentials if prompted and then select [Save](#) to save the path.

 **NOTE:** Use this format for the path: `\\server\folder`, where “server” is the name of the server that hosts the shared folder, and “folder” is the name of the shared folder. If the folder is nested inside other folders, complete all necessary segments of the path to reach the folder. For example: `\\server\folder\folder`

 **NOTE:** The [Folder Paths](#) field might have a pre-defined path, and it might not be editable. In this situation, the administrator has configured this folder for common access.

4. Touch the [File Name](#) text field to open a touchscreen keyboard, type the name for the file, and then select the Enter  button.
5. To configure settings, such as [File Type and Resolution](#), [Original Sides](#), and [Content Orientation](#), select [Options](#) in the lower left corner, and then select the settings from the [Options](#) menus. Select [Done](#) for each setting if prompted.
6. Optional Preview: Touch the right pane of the screen to preview the document. You can use the [Expand](#) and [Collapse](#) buttons on the left side of the preview pane to expand and collapse the preview screen.

[Expand](#) button



[Collapse](#) button



Use the buttons on the right of the screen to adjust the preview options and to rearrange, rotate, insert, or remove pages.



Toggle between the two-page view and the thumbnail view. More options are available in the thumbnail view than in the two-page view.



Zoom in or out on the selected page.

NOTE: Select only one page at a time to use these buttons.



Rotate the page 180 degrees.

NOTE: This button is available only in the thumbnail view.



Delete the selected pages.

NOTE: This button is available only in the thumbnail view.



Rearrange the pages within the document. Select one or more pages and move them to the left or right.

NOTE: These buttons are available only in the thumbnail view.



Add a page to the document. The printer prompts you to scan additional pages.



Clear the changes made in the preview and start over.

7. When the document is ready, select [Send](#) to save the file to the network folder.

Scan to USB drive

Introduction

The printer can scan a file and save it to a USB flash drive.

 **NOTE:** Before you can scan to a USB drive, your printer administrator or IT department must use the HP Embedded Web Server to enable the feature and set it up.

Scan to USB drive

 **NOTE:** You might be required to sign in to the printer to use this feature.

1. Place the document face-down on the scanner glass, or place it face-up in the document feeder and adjust the paper guides to fit the size of the document.
2. Insert the USB drive into the USB port near the printer control panel.
3. From the Home screen on the printer control panel, select [Scan](#), and then select [Scan to USB Drive](#).
4. Select the USB drive under [Destination](#), and then select the save location (either the root of the USB drive or an existing folder).
5. Touch the [File Name](#) text field to open a touchscreen keyboard, type the name for the file, and then select the Enter  button.
6. To configure settings, such as [File Type and Resolution](#), [Original Sides](#), and [Content Orientation](#) select [Options](#) in the lower left corner, and then select the settings from the [Options](#) menus. Select [Done](#) if prompted.
7. Optional Preview: Touch the right pane of the screen to preview the document. You can use the [Expand](#) and [Collapse](#) buttons on the left side of the preview pane to expand and collapse the preview screen.

Expand button



Collapse button



Use the buttons on the right of the screen to adjust the preview options and to rearrange, rotate, insert, or remove pages.



Toggle between the two-page view and the thumbnail view. More options are available in the thumbnail view than in the two-page view.





Zoom in or out on the selected page.

NOTE: Select only one page at a time to use these buttons.



Rotate the page 180 degrees.

NOTE: This button is available only in the thumbnail view.



Delete the selected pages.

NOTE: This button is available only in the thumbnail view.



Rearrange the pages within the document. Select one or more pages and move them to the left or right.

NOTE: These buttons are available only in the thumbnail view.



Add a page to the document. The printer prompts you to scan additional pages.



Clear the changes made in the preview and start over.

8. When the document is ready, select [Save](#) to save the file to the USB drive.

Scan to SharePoint

Introduction

If you have a workflow-equipped printer, you can scan a document and send it to a Microsoft® SharePoint site. This feature eliminates the need to scan the documents to a network folder, USB flash drive, or email message, and then manually upload the files to the SharePoint site.

Scan to SharePoint® supports all scanning options, including the ability to scan documents as images or use the OCR features to create text files or searchable PDFs.

 **NOTE:** Before you can scan to SharePoint, your printer administrator or IT department must use the HP Embedded Web Server to enable the feature and set it up.

Scan to SharePoint

1. Place the document face-down on the scanner glass, or place it face-up in the document feeder and adjust the paper guides to fit the size of the document.
2. From the Home screen on the printer control panel, select [Scan](#), and then select [Scan to SharePoint®](#).

 **NOTE:** It might be necessary to sign in to the printer to use this feature.

3. To select a Quick Set, touch [Select](#) under [Quick Sets](#), select a Quick Set, and then select [Load](#).
4. Select the [File Name:](#) text field to open a keyboard, type the name for the file, and then select the [Enter](#)  button.
5. To configure settings, such as [File Type and Resolution](#), [Sides](#), and [Content Orientation](#), select [Options](#) in the lower left corner, and then select the settings from the [Options](#) menus. Select [Done](#) if prompted.
6. Optional Preview: Touch the right pane of the screen to preview the document. You can use the [Expand](#) and [Collapse](#) buttons on the left side of the preview pane to expand and collapse the preview screen.

Expand button



Collapse button



Use the buttons on the right of the screen to adjust the preview options and to rearrange, rotate, insert, or remove pages.



Toggle between the two-page view and the thumbnail view. More options are available in the thumbnail view than in the two-page view.





Zoom in or out on the selected page.

NOTE: Select only one page at a time to use these buttons.



Rotate the page 180 degrees.

NOTE: This button is available only in the thumbnail view.



Delete the selected pages.

NOTE: This button is available only in the thumbnail view.



Rearrange the pages within the document. Select one or more pages and move them to the left or right.

NOTE: These buttons are available only in the thumbnail view.



Add a page to the document. The printer prompts you to scan additional pages.



Clear the changes made in the preview and start over.

7. When the document is ready, select [Send](#) to save it to the SharePoint location.

Scan to job storage

- [Introduction](#)
- [Scan to job storage on the printer](#)
- [Print from job storage on the printer](#)

Introduction

The printer has a feature that enables it to scan a document and save it to a job storage folder on the printer. You can retrieve the document from the printer and print it when needed.

 **NOTE:** Before you can scan to a storage folder on the printer, your printer administrator or IT department must use the HP Embedded Web Server to enable the feature and configure the settings.

Scan to job storage on the printer



Use this procedure to scan a document and save it to a job storage folder on the printer so that you can print copies at any time.

1. Place the document face-down on the scanner glass, or place it face-up in the document feeder and adjust the paper guides to fit the size of the document.
2. From the Home screen on the printer control panel, select [Scan](#), and then select [Scan to Job Storage](#).

 **NOTE:** If prompted, enter your user name and password.

3. Select the default storage folder name shown under [Folder](#).

 **NOTE:** If the printer administrator has configured the option, you can create a new folder. Follow these steps to create a new folder:

- a. Select the [New Folder](#)  icon.
 - b. Select the [New Folder](#) field, type the folder name, and then select [OK](#).
4. Make sure that you have selected the correct folder.
 5. Touch the [Job Name](#) text field to open a touchscreen keyboard, type the name for the file, and then select the Enter  button.
 6. To make the job private, select the PIN  button, enter a four-digit PIN in the [PIN](#) field, and then close the touchscreen keypad.
 7. To configure settings, such as [Sides](#) and [Content Orientation](#), select [Options](#) in the lower left corner, and then select the settings from the [Options](#) menus. Select [Done](#) for each setting if prompted.
 8. Optional Preview: Touch the right pane of the screen to preview the document. You can use the [Expand](#) and [Collapse](#) buttons on the left side of the preview pane to expand and collapse the preview screen.

Expand button



Collapse button



Use the buttons on the right of the screen to adjust the preview options and to rearrange, rotate, insert, or remove pages.



Toggle between the two-page view and the thumbnail view. More options are available in the thumbnail view than in the two-page view.



Zoom in or out on the selected page.

NOTE: Select only one page at a time to use these buttons.



Rotate the page 180 degrees.

NOTE: This button is available only in the thumbnail view.



Delete the selected pages.

NOTE: This button is available only in the thumbnail view.



Rearrange the pages within the document. Select one or more pages and move them to the left or right.

NOTE: These buttons are available only in the thumbnail view.



Add a page to the document. The printer prompts you to scan additional pages.



Clear the changes made in the preview and start over.

9. When the document is ready, select [Save](#) to save the file to the storage folder.

Print from job storage on the printer

Use this procedure to print a scanned document that is in a job storage folder on the printer.

1. From the Home screen on the printer control panel, select **Print**, and then select **Print from Job Storage**.
2. Under **Stored Jobs to Print**, select **Choose**, select the folder in which the document is saved, select the document, and then select **Select**.
3. If the document is private, enter the four-digit PIN in the **Password** field, and then select **OK**.
4. To adjust the number of copies, touch the box to the left of the **Print** button, and then select the number of copies from the keypad that opens. Select the Close  button to close the keypad.
5. Select **Print** to print the document.

HP JetAdvantage business solutions

HP JetAdvantage solutions are workflow and printing solutions that are easy-to-use, and both network and cloud-based. HP JetAdvantage solutions are designed to help businesses of all types, including healthcare, financial services, manufacturing, and public sector, manage a fleet of printers and scanners.

HP JetAdvantage Solutions include:

- HP JetAdvantage Security solutions
- HP JetAdvantage Management solutions
- HP JetAdvantage Workflow solutions
- HP JetAdvantage Mobile Printing solutions

For more information about HP JetAdvantage business workflow and printing solutions, go to www.hp.com/go/PrintSolutions.

Additional scan tasks

Go to www.hp.com/support/pwcolor780MFP or www.hp.com/support/pwcolor785MFP.

Instructions are available for performing specific scan tasks, such as the following:

- Copy or scan pages from books or other bound documents
- Copy or scan both sides of an identification card
- Copy or scan a document into a booklet format

7 Fax

- [Set up fax](#)
- [Change fax configurations](#)
- [Send a fax](#)
- [Additional fax tasks](#)

For more information:

The following information is correct at the time of publication. For current information, see www.hp.com/support/pwcolor780MFP or www.hp.com/support/pwcolor785MFP.

HP's all-inclusive help for the printer includes the following information:

- Install and configure
- Learn and use
- Solve problems
- Download software and firmware updates
- Join support forums
- Find warranty and regulatory information

Set up fax

Introduction

This information applies to fax and Flow models, or to other printers when an optional analog fax accessory has been installed. Before continuing, connect the printer to a phone line (for analog fax) or to an Internet or network fax service.

Set up fax by using the printer control panel

1. From the Home screen on the printer control panel, select [Settings](#).
2. Open the following menus:
 - [Fax](#)
 - [Internal Fax Modem Setup](#)



NOTE: If the [Internal Fax Modem Setup](#) menu does not appear in the menu listing, LAN or Internet fax might be enabled. When LAN or Internet fax is enabled, the analog fax accessory is disabled and the [Internal Fax Modem Setup](#) menu does not display. Only one fax feature, either LAN fax, analog fax, or Internet fax, can be enabled at a time. To use analog fax when LAN fax is enabled, use the HP Embedded Web Server to disable LAN fax.

3. Select the location from the list on the right side of the screen, and then select [Next](#).
4. Touch the [Company Name](#) text field, and use the keypad to type the company name.
5. Touch the [Fax Number](#) text field, and use the keypad to type the sending fax number. Select [Next](#).
6. Verify that the date and time settings are correct. Make changes as necessary, and then select [Next](#).
7. If a dialing prefix is required for sending faxes, touch the [Dialing Prefix](#) text field, and use the keypad to enter the number.
8. Review all the information on the left pane, and then select [Finish](#) to complete the fax setup.

Change fax configurations

 **NOTE:** The settings configured using the control panel override any settings made in the HP Embedded Web Server.

- [Fax dialing settings](#)
- [General fax send settings](#)
- [Fax receive settings](#)

Fax dialing settings

1. From the Home screen on the printer control panel, select [Settings](#).
2. Open the following menus:
 - [Fax](#)
 - [Fax Send Settings](#)
 - [Fax Dialing Settings](#)

Configure any of the following settings, and then select [Done](#):

Menu item	Description
Redial on Error	The Redial on Error feature sets the number of times a fax number will be redialed when an error occurs during a fax transmission.
Redial on No Answer	The Redial on No Answer setting selects the number of times the fax accessory redials if the number dialed does not answer. The number of retries is either 0 to 1 (used in the U.S.) or 0 to 2, depending on the location setting. The interval between retries is set by the redial interval setting.
Redial on Busy	The Redial on Busy setting selects the number of times (0 through 9) the fax accessory redials a number when the number is busy. The interval between retries is set by the Redial Interval setting.
Redial Interval	The Redial Interval setting selects the number of minutes between retries if the number dialed is busy or not answering, or if an error occurs. NOTE: You might observe a redial message on the control panel when both the Redial on Busy and Redial on No Answer settings are set to off. This occurs when the fax accessory dials a number, establishes a connection, and then loses the connection. As a result of this error condition, the fax accessory performs three automatic redial attempts regardless of the redial settings. During this redial operation, a message displays on the control panel to indicate that a redial is in progress.
Fax Send Speed	The Fax Send Speed setting sets the modem bit rate (measured in bits per second) of the Analog Fax modem while sending a fax. <ul style="list-style-type: none">• Fast (v.34 – 33.6k)• Medium (v.17 – 14.4k)• Slow (v.29 – 9.6k)
Line Monitor Volume	Use the Line Monitor Volume setting to control the printer's dialing volume level when sending faxes.
Dialing Mode	The Dialing Mode setting sets the type of dialing that is used: either tone (touch-tone phones) or pulse (rotary-dial phones).

Menu item	Description
Dialing Prefix	The Dialing Prefix setting allows you to enter a prefix number (such as a "9" to access an outside line) when dialing. This prefix number is automatically added to all phone numbers when dialed.
Detect dial tone	The Detect dial tone setting determines whether the fax checks for a dial tone before sending a fax.

General fax send settings

1. From the Home screen on the printer control panel, select [Settings](#).
2. Open the following menus:
 - [Fax](#)
 - [Fax Send Settings](#)
 - [General Fax Send Settings](#)

Configure any of the following settings, and then select [Done](#):

Menu item	Description
Fax Number Confirmation	When the Fax Number Confirmation feature is enabled, the fax number must be entered twice to ensure that it was entered correctly. The feature is disabled by default.
PC Fax Send	Use the PC Fax Send feature to send faxes from a PC. This feature is enabled by default.
Error Correction Mode	<p>Normally, the fax accessory monitors the signals on the telephone line while it is sending or receiving a fax. If the fax accessory detects an error during the transmission and the Error Correction Mode setting is on, the fax accessory can request that the error portion of the fax be sent again.</p> <p>The Error Correction Mode feature is enabled by default. You should turn it off only if you are having trouble sending or receiving a fax and if you are willing to accept the errors in the transmission and a probable quality reduction in the image. Turning off the setting might be useful when you are trying to send a fax overseas or receive one from overseas, or if you are using a satellite telephone connection.</p> <p>NOTE: Some VoIP providers might suggest turning off the Error Correction Mode setting. However, this is not usually necessary.</p>
Fax Header	Use the Fax Header feature to control whether the header is appended to the top, and content is shifted down, or if the header is overlaid on top of the previous header.

Fax receive settings

1. From the Home screen on the printer control panel, select [Settings](#).
2. Open the following menus:
 - [Fax](#)
 - [Fax Receive Settings](#)
 - [Fax Receive Setup](#)

Configure any of the following settings, and then select [Done](#):

Menu item	Description
Receive Mode	<p>The Receive Mode setting determines how the fax accessory receives fax jobs. Select one of the following options:</p> <ul style="list-style-type: none"> • Automatic • TAM • Fax/Tel • Manual
Rings to Answer	<p>The Rings to Answer setting determines the number of times the phone rings before the call is answered by the fax accessory.</p> <p>NOTE: The default range for the available options for the Rings to Answer setting is location-specific. The range of possible Rings to Answer options is limited by location.</p> <p>If the fax accessory is not answering, and the Rings to Answer setting is 1, try increasing it to 2.</p>
Ring Volume	The Ring Volume setting allows you to adjust the ringer volume.
Fax Receive Speed	<p>Touch the Fax Receive Speed drop down menu and select one of the following options:</p> <ul style="list-style-type: none"> • Fast (v.34 – 33.6k) • Medium (v.17 – 14.4k) • Slow (v.29 – 9.6k)
Extension Phone	This setting allows you use a separate telephone in conjunction with the fax functions.
Allow Reprinting	This setting allows you to reprint received faxes.
Receive to PC	This setting allows you to receive faxes directly to your computer.
Fax Polling	This setting allows you to enable or disable the fax polling function.
Fax/Tel Ring Time	This setting determines the number of times the phone rings before the fax/tel mode initiates.

Send a fax

1. Place the document face-down on the scanner glass, or place it face-up in the document feeder and adjust the paper guides to fit the size of the document.
2. From the Home screen on the printer control panel, select **Fax**. You might be prompted to type a user name and password.
3. Specify the recipients by using one of these methods:

Enter recipients manually

- ▲ Touch the **Fax Recipients** text field, and then use the keypad to enter the fax number. To send to multiple fax numbers, separate the numbers with a semicolon, or select the Enter  button on the touchscreen keyboard after typing each number.

Enter recipients from the Contacts list

- a. Select the Contacts  button that is next to the **Fax Recipients** field to open the **Contacts** screen.
 - b. Select the appropriate contact list.
 - c. Select a name or names from the list of contacts to add to the recipients list, and then select **Add**.
4. To load a Quick Set, select **Load**, select the Quick Set, and then select **Load** under the **Quick Sets** list.

 **NOTE:** **Quick Sets** are predefined settings for various types of output, such as **Text**, **Photograph**, and **High Quality**. You can select a Quick Set to view the description.

5. To configure settings, such as **Resolution**, **Sides**, and **Content Orientation**, select **Options** in the lower left corner, and then select the settings from the **Options** menus. Select **Done** if prompted.
6. Optional Preview: Touch the right pane of the screen to preview the document. You can use the **Expand** and **Collapse** buttons on the left side of the preview pane to expand and collapse the preview screen.

Expand button



Collapse button



Use the buttons on the right of the screen to adjust the preview options and to rearrange, rotate, insert, or remove pages.



Toggle between the two-page view and the thumbnail view. More options are available in the thumbnail view than in the two-page view.





Zoom in or out on the selected page.

NOTE: Select only one page at a time to use these buttons.



Rotate the page 180 degrees.

NOTE: This button is available only in the thumbnail view.



Delete the selected pages.

NOTE: This button is available only in the thumbnail view.



Rearrange the pages within the document. Select one or more pages and move them to the left or right.

NOTE: These buttons are available only in the thumbnail view.



Add a page to the document. The printer prompts you to scan additional pages.



Clear the changes made in the preview and start over.

7. When the document is ready, select [Send](#) to send the fax.

Additional fax tasks

Go to www.hp.com/support/pwcolor780MFP or www.hp.com/support/pwcolor785MFP.

Instructions are available for performing specific fax tasks, such as the following:

- Create and manage fax speed dial lists
- Configure fax billing codes
- Use a fax printing schedule
- Block incoming faxes
- Fax archiving and forwarding

8 Manage the printer

- [Advanced configuration with the HP Embedded Web Server \(EWS\)](#)
- [Create a Quick Set](#)
- [Configure IP network settings](#)
- [Printer security features](#)
- [Energy-conservation settings](#)
- [HP Web Jetadmin](#)
- [Software and firmware updates](#)

For more information:

The following information is correct at the time of publication. For current information, see www.hp.com/support/pwcolor780MFP or www.hp.com/support/pwcolor785MFP.

HP's all-inclusive help for the printer includes the following information:

- Install and configure
- Learn and use
- Solve problems
- Download software and firmware updates
- Join support forums
- Find warranty and regulatory information

Advanced configuration with the HP Embedded Web Server (EWS)

- [Introduction](#)
- [How to access the HP Embedded Web Server \(EWS\)](#)
- [HP Embedded Web Server features](#)

Introduction

Use the HP Embedded Web Server to manage printing functions from a computer instead of the printer control panel.

- View printer status information
- Determine the remaining life for all supplies and order new ones
- View and change tray configurations
- View and change the printer control-panel menu configuration
- View and print internal pages
- Receive notification of printer and supplies events
- View and change network configuration



The HP Embedded Web Server works when the printer is connected to an IP-based network. The HP Embedded Web Server does not support IPX-based printer connections. Internet access is not needed to open and use the HP Embedded Web Server.

When the printer is connected to the network, the HP Embedded Web Server is automatically available.



NOTE: The HP Embedded Web Server is not accessible beyond the network firewall.

How to access the HP Embedded Web Server (EWS)

1. From the Home screen on the printer control panel, select the Information  icon, and then select the Network  icon to display the IP address or host name.
2. Open a web browser, and in the address line, type the IP address or host name exactly as it displays on the printer control panel. Press the **Enter** key on the computer keyboard. The EWS opens.

 <https://10.10.XX.XX/>



NOTE: If the web browser displays a message indicating that accessing the website might not be safe, select the option to continue to the website. Accessing this website will not harm the computer.

To use the HP Embedded Web Server, the browser must meet the following requirements:

Windows® 7

- Internet Explorer (version 8.x or greater)
- Google Chrome (version 34.x or greater)
- Firefox (version 20.x or greater)

Windows® 8 or greater

- Internet Explorer (version 9.x or greater)
- Google Chrome (version 34.x or greater)
- Firefox (version 20.x or greater)

OS X

- Safari (version 5.x or greater)
- Google Chrome (version 34.x or greater)

Linux

- Google Chrome (version 34.x or greater)
- Firefox (version 20.x or greater)

HP Embedded Web Server features

- [Information tab](#)
- [General tab](#)
- [Copy/Print tab](#)
- [Scan/Digital Send tab](#)
- [Fax tab](#)
- [Troubleshooting tab](#)
- [Security tab](#)
- [HP Web Services tab](#)
- [Networking tab](#)
- [Other Links list](#)

Information tab

Table 8-1 HP Embedded Web Server Information tab

Menu	Description
Device Status	Shows the printer status and shows the estimated life remaining of HP supplies. The page also shows the type and size of paper set for each tray. To change the default settings, click the Change Settings link.
Job Log	Shows a summary of all jobs the printer has processed.
Configuration Page	Shows the information found on the configuration page.
Supplies Status Page	Shows the status of the supplies for the printer.
Event Log Page	Shows a list of all printer events and errors. Use the HP Instant Support link (in the page footer on all HP Embedded Web Server pages) to connect to a set of dynamic web pages that help solve problems. These pages also show additional services available for the printer.

Table 8-1 HP Embedded Web Server Information tab (continued)

Menu	Description
Usage Page	Shows a summary of the number of pages the printer has printed, grouped by size, type, and paper print path.
Device Information	Shows the printer network name, address, and model information. To customize these entries, click the Device Information menu on the General tab.
Control Panel Snapshot	Shows an image of the current screen on the control panel display.
Print	Upload a print-ready file from the computer to print. The printer uses the default print settings to print the file.
Printable Reports and Pages	Lists the internal reports and pages for the printer. Select one or more items to print or view.
Open Source Licenses	Shows a summary of the licenses for open source software programs that can be used with the printer.

General tab

Table 8-2 HP Embedded Web Server General tab

Menu	Description
Control Panel Customization	Reorder, show, or hide features on the control-panel display. Change the default display language and keyboard layouts.
Quick Sets	Configure jobs that are available in the Quick Sets area of the Home screen on the printer control panel.
Alerts	Setup email alerts for various printer and supplies events.
Control Panel Settings App	Shows the Settings app options that are available on the printer control panel.
General Settings	Configure how the printer recovers from jams and whether copy jobs initiated at the printer control panel take priority over print jobs.
AutoSend	Configure the printer to send automated emails regarding printer configuration and supplies to specific email addresses.
Edit Other Links	Add or customize a link to another website. This link displays in the footer area on all HP Embedded Web Server pages.
Ordering Information	Enter information about ordering replacement cartridges. This information displays on the supplies status page.
Device Information	Name the printer and assign an asset number to it. Enter the name of the primary contact who will receive information about the printer.
Language	Set the language in which to display the HP Embedded Web Server information.
Date/Time Settings	Set the date and time or synchronize with a network time server.
Energy Settings	Set or edit sleep settings for business and non-business hours and wake, sleep, and holiday events for the printer. Set which interactions with the printer cause it to wake from sleep mode.
Backup and Restore	Create a backup file that contains printer and user data. If necessary, use this file to restore data to the printer.
Reset Factory Settings	Restore printer settings to the factory defaults.

Table 8-2 HP Embedded Web Server General tab (continued)

Menu	Description
Solution Installer	Install third-party software packages that extend or modify the functionality of the printer.
Firmware Upgrade	Download and install printer firmware upgrade files.
Quota and Statistics Services	Provides connection information about third-party job-statistics services.

Copy/Print tab

Table 8-3 HP Embedded Web Server Copy/Print tab

Menu	Description
Print from USB Drive Settings	Enable or disable the Print from USB Drive menu on the control panel.
Manage Stored Jobs	Enable or disable the ability to store jobs in the printer memory. Configure job-storage options.
Default Print Options	Configure the default options for print jobs.
Restrict Color (Color printers only)	Permit or restrict color printing and copying. Specify permissions for individual users or for jobs that are sent from specific software programs.
PCL and PostScript Settings	Adjust the PCL and PostScript settings for all print jobs, including copy jobs and received faxes.
Print Quality	Configure the print quality settings, including color adjustment, image registration, and allowed paper types.
Manage Supplies	Configure how the printer reacts when supplies reach a Very Low state.
Copy Settings	Configure the default options and Quick Sets for copy jobs. NOTE: If job-specific copy setting options are not set from the control panel at the start of a job, the default settings will be used for the job.
Manage Trays	Configure settings for paper trays.

Scan/Digital Send tab

Table 8-4 HP Embedded Web Server Scan/Digital Send tab

Menu	Description
Email Setup	Configure the default email settings for digital sending, including the following: <ul style="list-style-type: none">• Settings for the outgoing mail (SMTP) server• Settings for Email Quick Sets jobs• Default message settings, such as the "From" address and the subject line• Settings for digital signatures and encryption• Settings for email notifications• Default scan settings for email jobs• Default file settings for email jobs
Scan to Network Folder	Configure the network folder settings for digital sending, including the following: <ul style="list-style-type: none">• Settings for Quick Sets jobs saved in a network folder• Settings for notifications• Default scan settings for jobs saved in a network folder• Default file settings for jobs saved in a network folder
Scan to SharePoint® (Flow models only)	Configure the Microsoft SharePoint® settings for digital sending, including the following: <ul style="list-style-type: none">• Settings for Quick Sets jobs saved in a document library on the SharePoint® site• Default settings for jobs saved in a document library on the SharePoint® site
Scan to USB Drive	Configure the USB settings for digital sending, including the following: <ul style="list-style-type: none">• Settings for Quick Sets jobs saved on a USB flash drive• Settings for notifications• Default scan settings for jobs saved on a USB flash drive• Default file settings for jobs saved on a USB flash drive
Contacts	Manage contacts, including the following: <ul style="list-style-type: none">• Add email addresses into the printer one at a time.• Import a large list of frequently-used email addresses on to the printer all at once, rather than adding them one at a time.• Export contacts from the printer into a .CSV file on the computer to use as a data backup, or import the records onto another HP printer.• Edit email addresses that have already been saved in the printer.
Preferences	Configure size detection from the scanner glass.
Email and Scan to Network Folder Quick Setup Wizards	Configure the printer to send scanned images as email attachments. Configure the printer to save scanned images to network-folder Quick Sets. Quicks Sets provide easy access to files saved on the network.
Digital Sending Software Setup	Configure settings related to using optional Digital Sending software.

Fax tab

Table 8-5 HP Embedded Web Server Fax tab

Menu	Description
Fax Send Setup	Configure settings for sending faxes, including the following: <ul style="list-style-type: none">• Default settings for outgoing faxes• Settings for fax Quick Sets jobs• Settings for notifications• Default setting for sending faxes using the internal fax modem• Settings for using a LAN fax service• Settings for using an Internet fax service
Fax Speed Dials	Manage speed dials, including the following: <ul style="list-style-type: none">• Import .CSV files containing email addresses, fax numbers, or user records, so that they can be accessed on this printer.• Export email, fax, or user records from the printer into a file on the computer to use as a data backup, or import the records onto another HP printer.
Fax Receive Setup	Configure default print options for incoming faxes, and set up a fax printing schedule.
Fax Archive and Forwarding	Enable or disable fax archiving and fax forwarding, and configure basic settings for each: <ul style="list-style-type: none">• Fax archiving is a method to send a copy of all incoming and outgoing faxes to an email address, a network folder, or an FTP server.• Fax forwarding is a method to forward incoming faxes to a different fax device.
Fax Activity Log	Contains a list of the faxes that have been sent from or received by this printer.

Troubleshooting tab

Table 8-6 HP Embedded Web Server Troubleshooting tab

Menu	Description
General Troubleshooting	Select from a variety of reports and tests to help solve problems with the printer. Configure settings for Fax, OXPd, and Auto Recovery.
Online Help	Link to HP cloud-based online help to assist in troubleshooting printing issues.
Diagnostic Data	Export printer information to a file that can be useful for detailed problem analysis. NOTE: This item is available only if an administrator password is set from the Security tab.
Firmware Upgrade	Download and install printer firmware upgrade files.
Reset Factory Settings	Reset printer settings to factory defaults.

Security tab

Table 8-7 HP Embedded Web Server Security tab

Menu	Description
General Security	Settings for general security, including the following: <ul style="list-style-type: none">• Configure an administrator password to restrict access to certain features on the printer.• Set PJI password for processing PJI commands.• Set file system access and firmware upgrade security.• Enable or disable the Host USB port on the control panel or the USB connectivity port on the formatter for printing directly from a computer.• View the status of all security settings.
Account Policy	Enable administrator account settings.
Access Control	Configure access to printer functions for specific individuals or groups, and select the method individuals use to sign in to the printer.
Protect Stored Data	Configure and manage the internal hard drive for the printer. This printer includes an encrypted hard drive for maximum security. Configure settings for jobs that are stored on the printer hard drive.
Certificate Management	Install and manage security certificates for access to the printer and the network.
Web Service Security	Allow resources on this printer to be accessed by web pages from different domains. If no sites are added to the list, then all sites are trusted.
Self Test	Verify that the security functions are running according to expected system parameters.

HP Web Services tab

Use the **HP Web Services** tab to configure and enable HP Web Services for this printer. It is necessary to enable HP Web Services to use the HP ePrint feature.

Table 8-8 HP Embedded Web Server HP Web Services tab

Menu	Description
Web Services Setup	Connect this printer to HP's ePrintCenter on the web by enabling HP Web Services.
Web Proxy	Configure a proxy server if there are issues enabling HP Web Services or connecting the printer to the Internet.
HP JetAdvantage	Access solutions that extend the capabilities of the printer.

Networking tab

Use the **Networking** tab to configure and secure network settings for the printer when it is connected to an IP-based network. This tab does not display if the printer is connected to other types of networks.

Table 8-9 HP Embedded Web Server Networking tab

Menu	Description
Configuration	
Wi-Fi Direct	Configure Wi-Fi Direct settings for printers that include embedded Wi-Fi Direct Print and NFC printing or that have a wireless accessory installed. NOTE: The configuration options available depend on the print server model.
TCP/IP Setting	Configure TCP/IP settings for IPv4 and IPv6 networks. NOTE: The configuration options available depend on the print server model.
Network Settings	Configure IPX/SPX, AppleTalk, DLC/LLC, and SNMP settings, depending on the print server model.
Other Settings	Configure general printing protocols and services supported by the print server. The available options depend on the print server model, but can include firmware update, LPD queues, USB settings, support information, and refresh rate.
AirPrint	Enable, set up, or disable network printing from Apple supported printers.
Select Language	Change the language displayed by the HP Embedded Web Server. This page displays if the web pages support multiple languages. Optionally, select supported languages through language-preference settings in the browser.
Select Location	Select a country/region for the printer
Google Cloud Print	
Setup	Set up Google Cloud Print options.
Web Proxy	Configure proxy settings.
Security	
Settings	View and restore current security settings to factory-default values. Configure security settings using the Security Configuration Wizard. NOTE: Do not use the Security Configuration Wizard to configure security settings using network-management applications, such as HP Web Jetadmin.
Authorization	Control configuration management and use of this printer, including the following: <ul style="list-style-type: none"> • Set or change the administrator password to control access to configuration parameters. • Request, install, and manage digital certificates on the HP Jetdirect print server. • Limit host access to this printer through an Access Control List (ACL) (for selected print servers on IPv4 networks only).
Secure Communication	Configure security settings.

Mgmt. Protocols	<p>Configure and manage security protocols for this printer, including the following:</p> <ul style="list-style-type: none"> • Set the security management level for the HP Embedded Web Server, and control traffic over HTTP and HTTPS. • Configure the SNMP (Simple Network Management Protocol) operation. Enable or disable the SNMP v1/v2c or SNMP v3 agents on the print server. • Control access through protocols that may not be secure, such as printing protocols, print services, discovery protocols, name resolution services, and configuration-management protocols.
802.1X Authentication	<p>Configure 802.1X authentication settings on the Jetdirect print server as required for client authentication on the network, and reset the 802.1X authentication settings to factory-default values.</p> <p>CAUTION: When changing the 802.1X authentication settings; the printer might lose its connection. To reconnect, it might be necessary to reset the print server to a factory-default state and reinstall the printer.</p>
IPsec/Firewall	View or configure a Firewall policy or an IPsec/Firewall policy (for selected HP Jetdirect models only).
Announcement Agent	Enable or disable the HP Device Announcement Agent, set the configuration server, and configure mutual authentication using certificates.
Diagnostics	
Network Statistics	Display network statistics that are collected and stored on the HP Jetdirect print server.
Protocol Info	View a list of network-configuration settings on the HP Jetdirect print server for each protocol.
Configuration Page	View the HP Jetdirect configuration page, which contains status and configuration information.

Other Links list



NOTE: Configure which links display in the footer of the HP Embedded Web Server by using the **Edit Other Links** menu on the **General** tab. The following are the default links.

Table 8-10 HP Embedded Web Server Other Links list

Menu	Description
Product Support	Connect to the support site for the printer to search for help on various topics.
Shop for Supplies	Connect to the HP SureSupply website for information on purchasing original HP supplies, such as cartridges and paper.
HP Instant Support	Connect to the HP website to find solutions to printer problems.

Create a Quick Set

- [Introduction](#)
- [Step one: Access the HP Embedded Web Server \(EWS\)](#)
- [Step two: Add and manage Quick Sets](#)

Introduction



Quick Sets are short-cut jobs that are available from the Home screen or within the [Quick Sets](#) feature on the printer control panel and do not impact the defaults set for the base application. To use a Quick Set on the printer control panel, enable the base application.

Create Quick Sets for the following base applications to improve job accuracy and decrease the time to complete a job:

- **Scan to Email** — Use Scan to Email Quick Sets to configure and save commonly used settings for sending jobs from the printer via email as email attachments.
- **Fax** — Use Fax Quick Sets to configure and save commonly used settings for fax jobs.
- **Scan to Network Folder** — Use Scan to Network Folder Quick Sets to configure and save commonly used settings for saving jobs to a network folder.
- **Scan to USB Drive** — Use Scan to USB Quick Sets to configure and save commonly used settings for saving jobs to a USB device.
- **Copy** — Use Copy Quick Sets to configure and save commonly used settings for copy jobs.
- **Scan to SharePoint®** (Flow models only) — Use Scan to SharePoint Quick Sets to configure and save commonly used settings for saving jobs to a SharePoint site.

Select from various job options, such as starting a job immediately upon selection of a quick set or requiring an image preview before starting a job.

Step one: Access the HP Embedded Web Server (EWS)

1. From the Home screen on the printer control panel, select the Information  icon, and then select the Network  icon to display the IP address or host name.
2. Open a web browser, and in the address line, type the IP address or host name exactly as it displays on the printer control panel. Press the [Enter](#) key on the computer keyboard. The EWS opens.

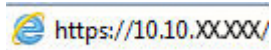

 **NOTE:** If the web browser displays a message indicating that accessing the website might not be safe, select the option to continue to the website. Accessing this website will not harm the computer.

The screenshot shows the HP EWS interface for a printer. The top navigation bar includes tabs for Information, General, Copy/Print, Scan/Digital Send, Fax, Troubleshooting, Security, HP Web Services, and Networking. The left sidebar lists various status and configuration pages. The main content area is titled 'Device Status' and shows 'Sleep mode on'. Below this, the 'Supplies' section displays four color cartridges (Black, Cyan, Magenta, Yellow) and two other components (Fuser Kit and Document Feeder Kit) with their respective levels and order numbers. A 'Media' table is also present, showing the status and capacity of different trays.

Input/Output	Status	Capacity	Size	Type
Tray 1	Empty	100 sheets	Any Size	Any Type
Tray 2	OK	550 sheets	Letter (8.5x11)	Plain
Standard bin	OK	250 sheets	N/A	N/A

Step two: Add and manage Quick Sets

Add a Quick Set

Use the following steps to add a new Quick Set.

1. Using the top navigation tabs, click **General**.
2. In the left navigation pane, click **Quick Sets**.
3. Click **Add**. The **Quick Sets Setup** page opens.

 **NOTE:** Click **Cancel** on any page of **Quick Sets Setup** to cancel the current changes, exit **Quick Sets Setup**, and return to the **Quick Sets** page.

4. Select a **Quick Set Type**, and then click **Next**. The following Quick Set types are available for selection, depending on your printer:



 **TIP:** A **Quick Set Type** only needs to be determined when a quick set is created by using the **General EWS** tab.

- Scan to E-mail
 - Fax
 - Scan to Network Folder
 - Scan to USB Drive
 - Copy (MFPs only)
 - Scan to SharePoint® (workflow printers only)
5. Enter a title for the Quick Set in the **Quick Set Name** (required) field.
 6. Enter a description of the Quick Set in the **Quick Set Description** field.

7. Select a **Quick Set Start Option** to determine what occurs after selecting a Quick Set on the printer control panel, and then click **Next**.
 8. Select settings and complete tasks in **Quick Sets Setup** wizard. Click **Next** to proceed to the next page of available options until reaching the **Summary** page.
-
-  **NOTE:** The settings available in **Quick Sets Setup** vary by the type of Quick Set being added. To see the available settings and options for each type of Quick Set, refer to the tables in the “Quick Set settings and options” section.
-
9. Review the summary of settings, and then click **Finish** to save the Quick Set, or click **Previous** to edit the settings.

Edit a Quick Set

Use the following steps to edit the settings of an existing Quick Set.

1. Using the top navigation tabs, click **General**.
 2. In the left navigation pane, click **Quick Sets**.
 3. In the **Quick Sets List** area, click the check box next to the appropriate Quick Set, and then click **Edit**. The **Quick Sets Setup** page opens.
-
-  **NOTE:** Click **Cancel** on any page of **Quick Sets Setup** to cancel the current changes, exit **Quick Sets Setup**, and return to the **Quick Sets** page.
-
4. If necessary, modify the following settings, and then click **Next**:
 - **Quick Set Name**
 - **Quick Set Description**
 - **Quick Set Start Option**
 5. Select settings and complete tasks in **Quick Sets Setup**. Click **Next** to proceed to the next page of available options until reaching the **Summary** page.
-
-  **NOTE:** The settings available in **Quick Sets Setup** vary by the type of Quick Set being edited. To see the available settings and options for each type of Quick Set, refer to the tables in the “Quick Set settings and options” section.
-
6. Review the **Summary** page, and then click **Finish** to save the changes made to the Quick Set.

Copy a Quick Set

1. Using the top navigation tabs, click **General**.
 2. In the left navigation pane, click **Quick Sets**.
 3. In the **Quick Sets List** area, click the check box next to the appropriate Quick Set, and then click **Copy**. The **Quick Sets Setup** page opens.
-
-  **NOTE:** Click **Cancel** on any page of **Quick Sets Setup** to cancel the current changes, exit **Quick Sets Setup**, and return to the **Quick Sets** page.
-
4. If necessary, modify the following settings, and then click **Next**:

- Quick Set Name
 - Quick Set Description
 - Quick Set Start Option
5. Select settings and complete tasks in **Quick Sets Setup**. Click **Next** to proceed to the next page of available options until reaching the **Summary** page.

 **NOTE:** The settings available in **Quick Sets Setup** vary by the type of Quick Set being copied. To see the available settings and options for each type of Quick Set, refer to the tables in the “Quick Set settings and options” section.

6. Review the **Summary** page, and then click **Finish** to save the changes made to the Quick Set.

Remove a Quick Set

Use the following steps to remove a Quick Set.

1. Using the top navigation tabs, click **General**.
2. In the left navigation pane, click **Quick Sets**.
3. In the **Quick Sets List** area, click the check box next to the appropriate Quick Set, and then click **Remove...**
4. When the **Confirmation Page** opens, click **Remove** to finish removing the Quick Set.

Quick Set settings and options

The following tables list the settings and options available in the Quick Set Wizard when adding, editing, or copying a Quick Set.

Table 8-11 Address and Message Field Control — Scan to Email Quick Sets

Option	Description
Address Field Restrictions	Use the Address Field Restrictions drop-down list to specify whether users can type an email address or select an email address from an address book
From:	Use the From: drop-down list to set the email address that displays in the From: field of the email. If Default From: is selected, the email address listed in the Default From: field is used. If User's address (sign-in required) is selected, the user is required to sign in to the printer with their email address when using the Quick Set. This field can be set to be user-editable.
Default From:	The Default From: field is used to define the email address used when Default From: is selected in the From: drop-down list.
Default Display Name:	Use this field to set the name displayed on the printer's control panel. If this field is not set, the value in the Default From: displays on the printer's control panel. This field is optional.

Table 8-11 Address and Message Field Control — Scan to Email Quick Sets (continued)

Option	Description
To:	Use these drop-down lists to set the email recipient, CC (carbon copy) and BCC (blind carbon copy) values.
CC:	The options for each of these fields are:
BCC:	
	<ul style="list-style-type: none"> • User's address (sign-in required) • Blank • Specify address
	These fields can be set to be user-editable
Subject:	Use this field to set the value that appears in the subject line of the email.
	This field can be set to be user-editable.
Message:	Use this field to set the value for the body of the email.
	This field can be set to be user-editable.

Table 8-12 Signing and Encryption — Scan to Email Quick Sets

Option	Description
Signing	Use the Signing drop-down list to specify whether the email sent using the Quick Set is digitally signed.
	This field can be set to be user-editable.
Hashing Algorithm	Use the Hashing Algorithm drop-down list to set the type hashing algorithm used with signed emails. The following hashing algorithms are available:
	<ul style="list-style-type: none"> • SHA-1 • SHA-256 (recommended) • SHA-384 • SHA-512
Encryption	Use the Encryption drop-down list to specify whether the email sent using the Quick Set is encrypted.
	This field can be set to be user-editable.
Encryption Algorithm	Use the Encryption Algorithm drop-down list to set the encryption algorithm used for encrypted emails sent using the Quick Set.
Attribute for Recipient Public Key	The Attribute for Recipient Public Key field is used to set the attribute used for retrieving the email recipient's public key from LDAP for signed or encrypted emails.
Use the recipient public key certificate to verify the recipient	Select this setting to use the recipient's public key certificate to verify the recipient.

Table 8-13 Scan settings — Scan to Email, Fax, Scan to Network Folder, Scan to SharePoint®, and Scan to USB Drive Quick Sets

Option	Description
Original Size	Specify the size for the original document.

Table 8-13 Scan settings — Scan to Email, Fax, Scan to Network Folder, Scan to SharePoint®, and Scan to USB Drive Quick Sets (continued)

Option	Description
Original Sides	Select whether the original document is single-sided or double-sided.
Optimize Text/Picture	<p>Optimize the job for the type of image being scanned: text, graphics, or photos.</p> <p>Select from the following options:</p> <ul style="list-style-type: none"> • Text: Use for documents that contain mostly text • Mixed: Use for documents with a mix of text and pictures • Printed picture: Use for line drawings and preprinted images, such as magazine clippings or pages from books <p>NOTE: If bands of irregular intensity print on the copies, try selecting Printed picture to improve the quality.</p> <ul style="list-style-type: none"> • Photograph: Use for photographic prints
Content Orientation	<p>Select the way the content of the original document is placed on the page:</p> <ul style="list-style-type: none"> • Portrait: The short edge of the page is along the top. • Landscape: The long edge of the page is along the top.
Background Cleanup	Select a value to remove faint images from the background or to remove a light background color.
Darkness	Select a value to adjust the darkness of the file.
Contrast	Select a value to adjust the contrast of the file.
Sharpness	Select a value to adjust the sharpness of the file.
Image Preview	Select whether to require or make optional a displayed preview of the job or to disable a preview.
Cropping options	Select whether or not to allow a job to be cropped and the type of cropping option.
	(not available for Fax)
Erase Edges (not available for Fax)	Select this setting to specify the width of edge margins to be erased, in either inches or millimeters, for the front side and back side of a job.
Resolution (Fax only)	Set the resolution for the file. Higher resolution images have more dots per inch (dpi), so they show more detail. Lower resolution images have fewer dots per inch and show less detail, but the file size is smaller.
Suppress blank pages (Fax only)	If the Suppress blank pages option is enabled, blank pages will be ignored.

Table 8-14 File settings — Scan to Email, Scan to Network Folder, Scan to SharePoint®, and Scan to USB Drive Quick Sets

Feature	Description
File Name Prefix	Set the default file name prefix used for files saved to a network folder.
File Name	<p>Default file name for the file to be saved.</p> <p>Select the User editable check box to make this setting editable at the printer control panel.</p>
File Name Suffix	<p>Set the default file name suffix used for files saved to a network folder.</p> <p>Duplicate filename suffix default [filename]_YYYYMMDDT</p>

Table 8-14 File settings — Scan to Email, Scan to Network Folder, Scan to SharePoint®, and Scan to USB Drive Quick Sets (continued)

Feature	Description
File Name Preview	Enter a file name, and then click the Update Preview button.
File Numbering Format	Select a file name format for when the job is divided into multiple files.
Add numbering when job has just one file (ex. _1-1)	Select this setting to add numbering to a file name when the job is only one file instead of multiple files.
File Type	Select the file format for the saved file. Select the User editable check box to make this setting editable at the printer control panel.
High Compression (smaller file)	Select this setting to compress the scanned file, which reduces the file size. However, the scanning process for a High compression file might take longer than for a Normal compression file.
PDF encryption	If the file type is PDF, then this option encrypts the output PDF file. A password must be specified as part of the encryption. The same password must be used to open the file. The user will be prompted to enter a password prior to scanning their job if one has not been set prior to pressing start.
Resolution	Set the resolution for the file. Higher resolution images have more dots per inch (dpi), so they show more detail. Lower resolution images have fewer dots per inch and show less detail, but the file size is smaller.
Quality and File Size	Select the quality for the file. Higher-quality images require a larger file size than lower-quality images, and they take more time to send.
Color/Black	Specify whether copies are to be scanned in color, black and gray, or black only.
Suppress blank pages	If the Suppress blank pages option is enabled, blank pages will be ignored.
Meta Data File Format (Scan to Network Folder Quick Sets only)	Use the drop-down list to select the file format for meta-data information. The options for this field are: <ul style="list-style-type: none"> • None • XML • HPS
Create Multiple Files	Select this setting to scan pages into separate files based on a predetermined maximum number of pages per file.

Table 8-15 Copy settings — Copy Quick Sets

Option	Description
Copies	Set the default number of copies.
Sides	Select a Sides option: <ul style="list-style-type: none"> • Original Sides <ul style="list-style-type: none"> – 1-sided – 2-sided • Output Sides <ul style="list-style-type: none"> – 1-sided – 2-sided

Table 8-15 Copy settings — Copy Quick Sets (continued)

Option	Description
Color/Black	<p>Specify whether copies are printed in color or in black and white:</p> <ul style="list-style-type: none"> • Automatically detect: Prints color documents in color (for printers that support color copying), and black and white documents in black and white. For mixed documents, the printer will determine whether to print in color or black and white. • Color: Prints documents in color (for printers that support color copying). • Black: Prints documents in black and white.
Scan Mode	<p>Select the type of document to scan:</p> <ul style="list-style-type: none"> • Standard Document: Scan a page or stack of pages through the document feeder, or individually on the flatbed glass. • 2-sided ID: Scan each side of an identification card on the flatbed glass and output them onto one page. After scanning the first side, the printer prompts to place the second side in the correct position on the glass. • Book Mode: Scan an open book and output each page of the book onto different pages.
Reduce/Enlarge	<p>Use the Reduce/Enlarge feature to scale the size of the document up or down.</p> <p>Select a Reduce/Enlarge option:</p> <ul style="list-style-type: none"> • Automatic: The printer automatically scales the image to fit the paper size in the tray. • Manual: To reduce the image, type a scaling percentage that is less than 100. To enlarge the image, type a scaling percentage that is greater than 100.
Original Size	<p>Specify the size for the original document.</p>
Paper Selection	<p>Select the paper size and type and which tray to use for the copies.</p>
Booklet	<p>Enable or disable Booklet Format, and select whether to Borders on each page.</p>
Content Orientation	<p>Select the way the content of the original document is placed on the page:</p> <ul style="list-style-type: none"> • Portrait: The short edge of the page is along the top. • Landscape: The long edge of the page is along the top.
Pages per Sheet	<p>Select how many pages to print on one sheet and the page order: to copy to one, two, or four Pages per Sheet and select whether to Add page borders.</p> <p>Pages per Sheet</p> <ul style="list-style-type: none"> • One • Two • Four <p>Page Order</p> <ul style="list-style-type: none"> • Right, then down: Prints the pages in rows • Down, then right: Prints the pages in columns <p>Click the Add page borders check box to add borders on the pages.</p>

Table 8-15 Copy settings — Copy Quick Sets (continued)

Option	Description
Image Adjustment	<p>Use the settings to improve the overall quality of the copy. For example, adjust the Darkness and Sharpness, and use the Background Cleanup setting to remove faint images from the background or to remove a light background color.</p> <ul style="list-style-type: none"> • Darkness: Adjust to increase or decrease the amount of white and black in the colors • Contrast: Adjust to increase or decrease the difference between the lightest and darkest color on the page • Background Cleanup: Adjust if you are having trouble copying a faint image • Sharpness: Adjust to sharpen or soften the image. For example, increasing the sharpness could make text look clearer, but decreasing it could make photographs look smoother.
Optimize Text/Picture	<p>Optimize the job for the type of image being scanned: text, graphics, or photos.</p> <p>Select from the following options:</p> <ul style="list-style-type: none"> • Text: Use for documents that contain mostly text • Mixed: Use for documents with a mix of text and pictures • Printed picture: Use for line drawings and preprinted images, such as magazine clippings or pages from books <p>NOTE: If bands of irregular intensity print on the copies, try selecting Printed picture to improve the quality.</p> <ul style="list-style-type: none"> • Photograph: Use for photographic prints
Edge-to-Edge	<p>Use to avoid shadows that can display along the edges of copies when the original document is printed close to the edges.</p> <p>Combine this feature with the Reduce/Enlarge feature to ensure that the entire page is printed on the copies.</p> <p>When the Edge-to-Edge feature is turned on, the printer minimizes margins and prints as close to the edge of the paper as possible.</p>
Erase Edges	<p>Select this setting to specify the width of edge margins to be erased, in either inches or millimeters, for the front side and back side of a job.</p>
Collate	<p>For printers that support print-job finishing, each set of copied pages are assembled in the same order as the original document.</p> <p>NOTE: If the printer has a stapler installed, select a staple option. To not staple the copies, select None.</p> <p>Select a Collate option:</p> <ul style="list-style-type: none"> • Collate on: If making more than one copy, select to assemble pages in the correct order for each set of copies. • Collate off: Select to group the same pages together. For example, if making five copies of an original document that has two pages, all five first pages are grouped together and all five second pages are grouped together.
Image Preview	<p>Select whether to require or make optional a displayed preview of the job or to disable a preview.</p>

Example Quick Sets

Below is an example of what the **Quick Sets** area looks like after quick sets have been created.



Quick Sets

Help

Quick Sets List

Quick Sets are pre-configured sets of options that allow users to easily start a job without having to manually configure frequently used job settings. A Quick Set can be accessed from the Home screen or from the app associated with the Quick Set. Quick Sets are saved as unique jobs that do not impact the default options of the apps.

Show all 

<input type="checkbox"/> Quick Set Name	Status	Quick Set Type
<input type="checkbox"/> Home Screen		
<input type="checkbox"/> Quick Sets		
<input type="checkbox"/> Photo Quick Set		Copy
<input type="checkbox"/> Save to USB		Scan to USB Drive
<input type="checkbox"/> Test Network Folder		Scan to Network Folder

Quick Sets that are displayed on the control panel can only be moved using the [Control Panel Customization](#) page.

[Add...](#) [Edit...](#) [Copy...](#) [Remove...](#)

Configure IP network settings



- [Printer sharing disclaimer](#)
- [View or change network settings](#)
- [Rename the printer on a network](#)
- [Manually configure IPv4 TCP/IP parameters from the control panel](#)
- [Manually configure IPv6 TCP/IP parameters from the control panel](#)
- [Link speed and duplex settings](#)

Printer sharing disclaimer

HP does not support peer-to-peer networking, as the feature is a function of Microsoft operating systems and not of the HP printer drivers. Go to Microsoft at www.microsoft.com.

View or change network settings

Use the HP Embedded Web Server to view or change IP configuration settings.

1. Open the HP Embedded Web Server (EWS):
 - a. From the Home screen on the printer control panel, touch the Information  icon, and then touch the Network  icon to display the IP address or host name.
 - b. Open a web browser, and in the address line, type the IP address or host name exactly as it displays on the printer control panel. Press the **Enter** key on the computer keyboard. The EWS opens.

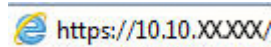



 **NOTE:** If the web browser displays a message indicating that accessing the website might not be safe, select the option to continue to the website. Accessing this website will not harm the computer.

2. Click the **Networking** tab to obtain network information. Change settings as needed.

Rename the printer on a network

To rename the printer on a network so that it can be uniquely identified, use the HP Embedded Web Server.

1. Open the HP Embedded Web Server (EWS):
 - a. From the Home screen on the printer control panel, touch the Information  icon, and then touch the Network  icon to display the IP address or host name.
 - b. Open a web browser, and in the address line, type the IP address or host name exactly as it displays on the printer control panel. Press the **Enter** key on the computer keyboard. The EWS opens.

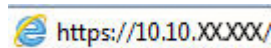

 **NOTE:** If the web browser displays a message indicating that accessing the website might not be safe, select the option to continue to the website. Accessing this website will not harm the computer.

2. Open the **General** tab.

3. On the **Device Information** page, the default printer name is in the **Device Name** field. You can change this name to uniquely identify this printer.



NOTE: Completing the other fields on this page is optional.

4. Click the **Apply** button to save the changes.

Manually configure IPv4 TCP/IP parameters from the control panel

Use the control-panel [Settings](#) menus to manually set an IPv4 address, subnet mask, and default gateway.

1. From the Home screen on the printer control panel, select [Settings](#).
2. Open the following menus:
 - [Networking](#)
 - [Ethernet](#)
 - [TCP/IP](#)
 - [IPV 4 Settings](#)
 - [Config Method](#)
3. Select the [Manual](#) option, and then select [OK](#).
4. Open the [Manual Settings](#) menu.
5. Select the [IP Address](#), [Subnet Mask](#), or [Default Gateway](#) option.
6. Touch the first field to open a keypad. Enter the correct digits for the field, and then select [OK](#).
Repeat the process for each field to be configured.

Manually configure IPv6 TCP/IP parameters from the control panel

Use the control-panel [Settings](#) menus to manually set an IPv6 address.

1. From the Home screen on the printer control panel, select [Settings](#).
2. To enable manual configuration, open the following menus:
 - [Networking](#)
 - [Ethernet](#)
 - [TCP/IP](#)
 - [IPV6 Settings](#)
3. Select [Enable](#), select [On](#), and then select [OK](#).
4. To configure the address, open the [Address](#) menu, and then touch the field to open a keypad.
5. Use the keypad to enter the address, and then select [OK](#).

Link speed and duplex settings



NOTE: This information applies only to Ethernet networks. It does not apply to wireless networks.

The link speed and communication mode of the print server must match the network hub. For most situations, leave the printer in automatic mode. Incorrect changes to the link speed and duplex settings might prevent the printer from communicating with other network devices. To make changes, use the printer control panel.



NOTE: The printer setting must match the setting for the network device (a network hub, switch, gateway, router, or computer).



NOTE: Making changes to these settings causes the printer to turn off and then on. Make changes only when the printer is idle.

1. From the Home screen on the printer control panel, swipe until the **Settings** menu displays. Touch the **Settings** icon to open the menu.
2. Open the following menus:
 - **Networking**
 - **Ethernet**
 - **Link Speed**
3. Select one of the following options:
 - **Auto:** The print server automatically configures itself for the highest link speed and communication mode allowed on the network.
 - **10T Half:** 10 megabytes per second (Mbps), half-duplex operation
 - **10T Full:** 10 Mbps, full-duplex operation
 - **10T Auto:** 10 Mbps, automatic-duplex operation
 - **100TX Half:** 100 Mbps, half-duplex operation
 - **100TX Full:** 100 Mbps, full-duplex operation
 - **100TX Auto:** 100 Mbps, automatic-duplex operation
 - **1000T Full:** 1000 Mbps, full-duplex operation
4. Select **OK**. The printer turns off and then on.

Printer security features

Introduction

The printer includes several security features to restrict who has access to configuration settings, to secure data, and to prevent access to valuable hardware components.



- [Security statements](#)
- [Assign an administrator password](#)
- [IP Security](#)
- [Lock the formatter](#)
- [Encryption support: HP High Performance Secure Hard Disks](#)

Security statements

The printer supports security standards and recommended protocols that help you keep the printer secure, protect critical information on your network, and simplify the way you monitor and maintain the printer.

Assign an administrator password

Assign an administrator password for access to the printer and the HP Embedded Web Server so that unauthorized users cannot change the printer settings.

1. Open the HP Embedded Web Server (EWS):
 - a. From the Home screen on the printer control panel, touch the Information  icon, and then touch the Network  icon to display the IP address or host name.
 - b. Open a web browser, and in the address line, type the IP address or host name exactly as it displays on the printer control panel. Press the **Enter** key on the computer keyboard. The EWS opens.

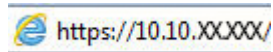

 **NOTE:** If the web browser displays a message indicating that accessing the website might not be safe, select the option to continue to the website. Accessing this website will not harm the computer.

2. Click the **Security** tab.
3. Open the **General Security** menu.
4. In the area labeled **Set the Local Administrator Password**, enter the name to associate with the password in the **Username** field.
5. Enter the password in the **New Password** field, and then enter it again in the **Verify Password** field.

 **NOTE:** To change an existing password, first enter the existing password in the **Old Password** field.

6. Click the **Apply** button.

 **NOTE:** Make note of the password and store it in a safe place. The administrator password cannot be recovered. If the administrator password is lost or forgotten, contact HP Support at support.hp.com for the assistance required to completely reset the printer.

Some features on the printer control panel can be secured so that unauthorized people cannot use them. When a feature is secured, the printer prompts you to sign in before you can use it. You can also sign in without waiting for a prompt by selecting [Sign In](#) from the printer control panel.

Typically, the credentials for signing in to the printer are the same as for signing in to the network. Consult the network administrator for this printer if you have questions about which credentials to use.

1. From the Home screen on the printer control panel, select [Sign In](#).
2. Follow the prompts to enter the credentials.

 **NOTE:** To maintain security for the printer, select [Sign Out](#) when you have finished using the printer.

IP Security

IP Security (IPsec) is a set of protocols that control IP-based network traffic to and from the printer. IPsec provides host-to-host authentication, data integrity, and encryption of network communications.

For printers that are connected to the network and have an HP Jetdirect print server, you can configure IPsec by using the **Networking** tab in the HP Embedded Web Server.



Lock the formatter

The formatter has a slot that you can use to attach a security cable. Locking the formatter prevents someone from removing valuable components from it.

Encryption support: HP High Performance Secure Hard Disks

The hard disk provides hardware-based encryption so you can securely store sensitive data without impacting printer performance. This hard disk uses the latest Advanced Encryption Standard (AES) and has versatile time-saving features and robust functionality.

Follow these steps to configure the disk in the HP Embedded Web Server:

1. From the Home screen on the printer control panel, select the Information  icon, and then select the Network  icon to display the IP address or host name.
2. Open a web browser, and in the address line, type the IP address or host name exactly as it displays on the printer control panel. Press the [Enter](#) key on the computer keyboard. The EWS opens.

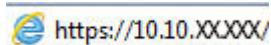
 <https://10.10.XX.XX/>

 **NOTE:** If the web browser displays a message indicating that accessing the website might not be safe, select the option to continue to the website. Accessing this website will not harm the computer.

3. Click the **Security** tab.
4. Open the **Protect Stored Data** menu.
5. Configure the desired options and then click **Apply**.

Energy-conservation settings

Introduction

- [Set the sleep timer and configure the printer to use 1 watt or less of power](#)
- [Set the sleep schedule](#)

Configure sleep settings to reduce power usage when the printer is idle.

Set the sleep timer and configure the printer to use 1 watt or less of power

The sleep settings affect how much power the printer uses, the wake/sleep time, how quickly the printer enters sleep mode, and how quickly the printer wakes up from sleep mode.

To configure the printer to use 1 watt or less of power while in sleep mode, enter times for both the [Sleep after Inactivity](#) and [Auto Off after sleep](#) settings.

1. From the Home screen on the printer control panel, select [Settings](#).
2. Open the following menus:
 - [General](#)
 - [Energy Settings](#)
 - [Sleep Settings](#)
3. Select [Sleep after Inactivity](#) to specify the number of minutes the printer is inactive before it enters sleep mode. Enter the appropriate time period.
4. Select [Auto Off after sleep](#) to put the printer into a deeper power save mode after a period of sleep. Enter the appropriate time period.



NOTE: By default, the printer will wake from Auto Off in response to any activity other than USB or Wi-Fi. For greater energy settings, you can set it to wake only to the power button by selecting [Shut down \(wake on power button only\)](#).

5. Select [Done](#) to save the settings.

Set the sleep schedule

Use the [Sleep Schedule](#) feature to configure the printer to automatically wake or go into Sleep mode at specific times on specific days of the week.

1. From the Home screen on the printer control panel, select [Settings](#).
2. Open the following menus:
 - [General](#)
 - [Energy Settings](#)
 - [Sleep Schedule](#)

3. Select the [New Event](#) button, and then select the type of event to schedule: [Wake Event](#) or [Sleep Event](#).
4. For a wake or sleep event, configure the time and the days of the week for the event. Select [Save](#) to save the setting.

HP Web Jetadmin

HP Web Jetadmin is an award-winning, industry-leading tool for efficiently managing a wide variety of networked HP products, including printers, multifunction printers, and digital senders. This single solution allows you to remotely install, monitor, maintain, troubleshoot, and secure your printing and imaging environment — ultimately increasing business productivity by helping you save time, control costs, and protect your investment.

HP Web Jetadmin upgrades are periodically made available to provide support for specific product features. Go to www.hp.com/go/webjetadmin for more information.

Software and firmware updates

HP regularly updates features that are available in the printer firmware. To take advantage of the most current features, update the printer firmware. Download the most recent firmware update file from the web:

Go to www.hp.com/support/pwcolor780MFP or www.hp.com/support/pwcolor785MFP. Click **Software and Drivers**.

9 Solve problems

- [Customer support](#)
- [Control panel help system](#)
- [Restore factory settings](#)
- [A “Cartridge is low” or “Cartridge is very low” message displays on the printer control panel](#)
- [Printer does not pick up paper or misfeeds](#)
- [Clear paper jams](#)
- [Improve print quality](#)
- [Improve copy image quality](#)
- [Improve scan image quality](#)
- [Improve fax image quality](#)
- [Solve wired network problems](#)
- [Solve wireless network problems](#)
- [Solve fax problems](#)

For more information:

The following information is correct at the time of publication. For current information, see www.hp.com/support/pwcolor780MFP or www.hp.com/support/pwcolor785MFP.

HP's all-inclusive help for the printer includes the following information:

- Install and configure
- Learn and use
- Solve problems
- Download software and firmware updates
- Join support forums
- Find warranty and regulatory information

Customer support

Get telephone support for your country/region	Country/region phone numbers are on the flyer that was in the box with the printer or at support.hp.com .
Have the printer name, serial number, date of purchase, and problem description ready	
Get 24-hour Internet support, and download software utilities and drivers	www.hp.com/support/pwcolor780MFP or www.hp.com/support/pwcolor785MFP
Order additional HP service or maintenance agreements	www.hp.com/go/carepack
Register the printer	www.register.hp.com

Control panel help system

The printer has a built-in Help system that explains how to use each screen. To open the Help system, select the Help  button in the upper-right corner of the screen.



For some screens, the Help opens to a global menu where you can search for specific topics. You can browse through the menu structure by touching the buttons in the menu.

Some Help screens include animations that show specific procedures, such as clearing paper jams.

If the printer alerts of an error or warning, touch the Help  button to open a message that describes the problem. The message also contains instructions to help solve the problem.

Restore factory settings

Introduction

Use one of the following methods to restore the printer to the original settings from the factory.

 **NOTE:** Restoring factory settings sets most of the printer settings to their factory defaults. However, some settings are not changed, such as language, date, time, and some network configuration settings.

Method one: Restore factory settings from the printer control panel



1. From the Home screen on the printer control panel, swipe until the **Settings** menu displays. Touch the **Settings** icon to open the menu.
2. Open the following menus:
 - **General**
 - **Reset Factory Settings**
3. Touch **Reset**.

A verification message advises that completing the reset function might result in loss of data.

4. Select **Reset** to complete the process.

 **NOTE:** The printer restarts automatically after the reset operation completes.

Method two: Restore factory settings from the HP Embedded Web Server (network-connected printers only)

1. Open the HP Embedded Web Server (EWS):
 - a. From the Home screen on the printer control panel, touch the Information  icon, and then touch the Network  icon to display the IP address or host name.
 - b. Open a web browser, and in the address line, type the IP address or host name exactly as it displays on the printer control panel. Press the **Enter** key on the computer keyboard. The EWS opens.

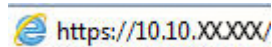

 **NOTE:** If the web browser displays a message indicating that accessing the website might not be safe, select the option to continue to the website. Accessing this website will not harm the computer.

2. Open the **General** tab.
3. On the left side of the screen, click **Reset Factory Settings**.
4. Click the **Reset** button.

 **NOTE:** The printer restarts automatically after the reset operation completes.

A “Cartridge is low” or “Cartridge is very low” message displays on the printer control panel

Cartridge is low: The printer indicates when a cartridge level is low. Actual cartridge life remaining may vary. Consider having a replacement available to install when print quality is no longer acceptable. The cartridge does not need to be replaced now.

Cartridge is very low: The printer indicates when the cartridge level is very low. Actual cartridge life remaining may vary. Consider having a replacement available to install when print quality is no longer acceptable. The cartridge does not need to be replaced now unless the print quality is no longer acceptable.

HP's Premium Protection Warranty expires near the end of useable cartridge life. Check the Supplies Status Page or the HP Embedded Web Server (EWS) for the status.

 **NOTE:** This printer is not designed to use continuous ink systems. To resume printing, remove continuous ink system and install genuine HP (or compatible) cartridges.

 **NOTE:** This printer is designed for ink cartridges to be used until they are empty. Refilling cartridges prior to depletion may cause your printer to fail. If this happens, insert a new cartridge (either genuine HP or compatible) to continue printing.

Change the “Very Low” settings

You can change the way the printer reacts when supplies reach the Very Low state. You do not have to re-establish these settings when you install a new cartridge.

1. From the Home screen on the printer control panel, select [Settings](#).
2. Open the following menus:
 - [Manage Supplies](#)
 - [Very Low Behavior](#)
 - [Black Cartridge](#) or [Color Cartridges](#)
3. Select one of the following options:
 - Select the [Stop](#) option to set the printer to stop printing when the cartridge reaches the **Very Low** threshold.
 - Select the [Continue](#) option to set the printer to alert you that the cartridge is very low, and to continue printing beyond the **Very Low** setting without interaction. This can result in unsatisfactory print quality.
 - Select the [Prompt to continue](#) option to set the printer to stop printing when the cartridge reaches the **Very Low** threshold. You can acknowledge the prompt or replace the cartridge to resume printing.

For printers with fax capability

When the printer is set to the [Stop](#) or [Prompt to continue](#) option, there is some risk that faxes will not print when the printer resumes printing. This can occur if the printer has received more faxes than the memory can hold while the printer is waiting.

The printer can print faxes without interruption when it passes the Very Low threshold if you select the [Continue](#) option for the cartridge, but print quality might degrade.

Order supplies

Order supplies and paper	www.hp.com/go/suresupply
Order through service or support providers	Contact an HP-authorized service or support provider.
Order using the HP Embedded Web Server (EWS)	To access, in a supported web browser on your computer, enter the printer IP address or host name in the address/URL field. The EWS contains a link to the HP SureSupply web site, which provides options for purchasing Original HP supplies.

Printer does not pick up paper or misfeeds

Introduction

The following solutions can help solve problems if the printer is not picking up paper from the tray or is picking up multiple sheets of paper at one time. Either of these situations can result in paper jams.

- [The printer does not pick up paper](#)
- [The printer picks up multiple sheets of paper](#)
- [The document feeder jams, skews, or picks up multiple sheets of paper](#)

The printer does not pick up paper

If the printer does not pick up paper from the tray, try these solutions.

1. Open the printer and remove any jammed sheets of paper. Verify that no torn remnants of paper remain inside the printer.
2. Load the tray with the correct size of paper for the job.
3. Make sure the paper size and type are set correctly on the printer control panel.

4. Make sure the paper guides in the tray are adjusted correctly for the size of paper. Adjust the guides to the appropriate indentation in the tray. The arrow on the tray guide should line up exactly with the marking on the tray.

 **NOTE:** Do not adjust the paper guides tightly against the paper stack. Adjust them to the indentations or markings in the tray.

The following images show examples of the paper-size indentations in the trays for various printers. Most HP printers have markings similar to these.

Figure 9-1 Size markings for Tray 1 or the multipurpose tray

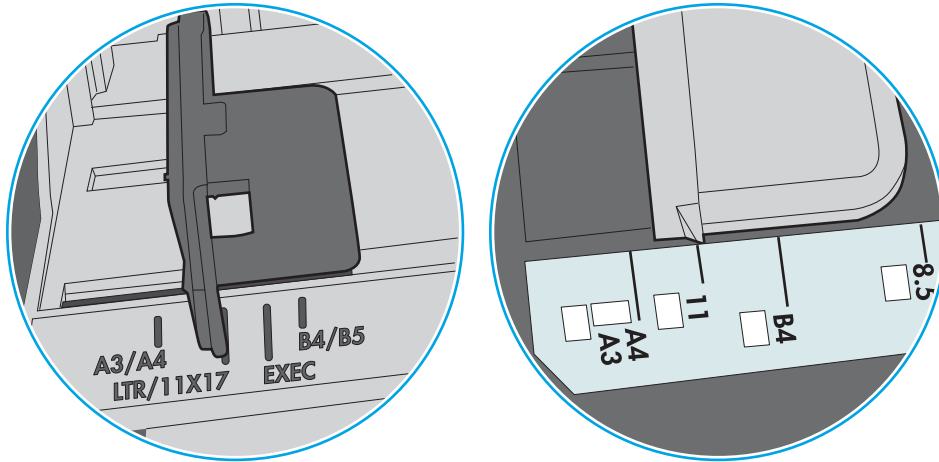
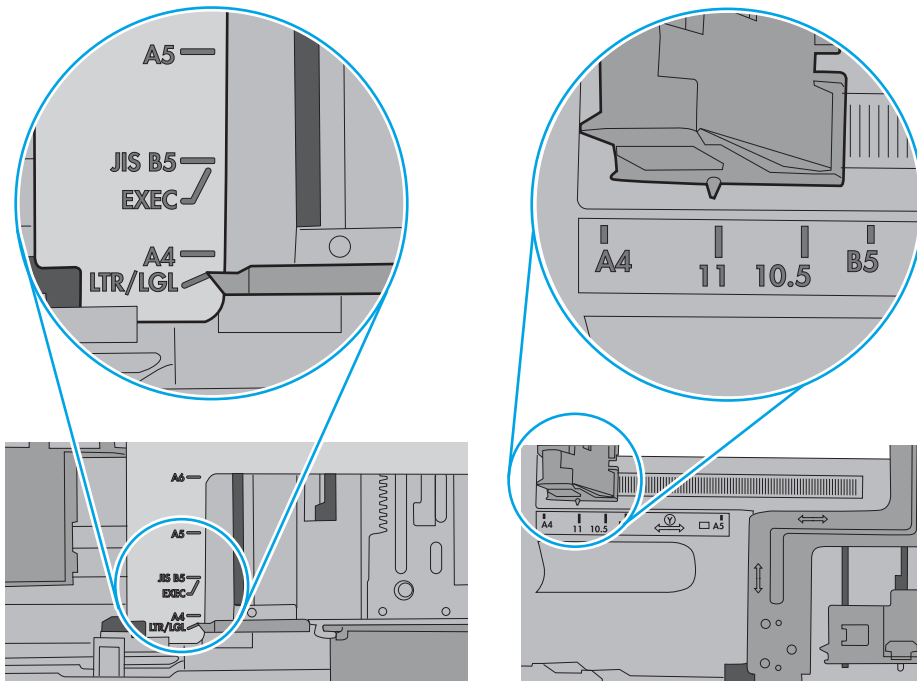

Figure 9-2 Size markings for cassette trays



5. Verify that the humidity in the room is within specifications for this printer and that paper is being stored in unopened packages. Most reams of paper are sold in moisture-proof wrapping to keep paper dry.

In high-humidity environments, paper at the top of the stack in the tray can absorb moisture, and it might have a wavy or uneven appearance. If this happens, remove the top 5 to 10 sheets of paper from the stack.

In low-humidity environments, excess static electricity can cause sheets of paper to stick together. If this happens, remove the paper from the tray, and flex the stack by holding it at each end and bringing the ends up to form a U shape. Then, rotate the ends down to reverse the U shape. Next, hold each side of the stack of paper, and repeat this process. This process releases individual sheets without introducing static electricity. Straighten the paper stack against a table before returning it to the tray.

Figure 9-3 Technique for flexing the paper stack

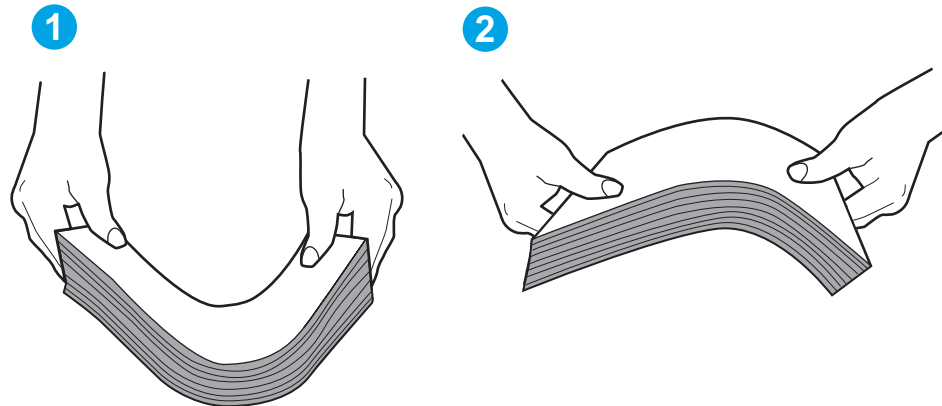

6. Check the printer control panel to see if it is displaying a prompt to feed the paper manually. Load paper, and continue.
7. The rollers above the tray might be contaminated. Clean the rollers with a lint-free cloth dampened with warm water. Use distilled water, if it is available.

CAUTION: Do not spray water directly on to the printer. Instead, spray water on the cloth or dab the cloth in water and wring it out before cleaning the rollers.

The following image shows examples of the roller location for various printers.

Figure 9-4 Roller locations for Tray 1 or the multipurpose tray

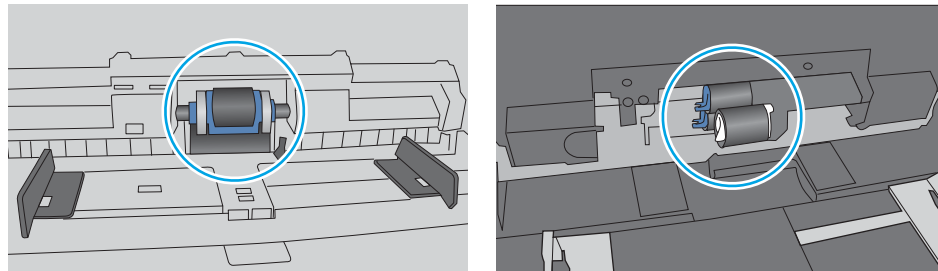

The printer picks up multiple sheets of paper

If the printer picks up multiple sheets of paper from the tray, try these solutions.

1. Remove the stack of paper from the tray and flex it, rotate it 180 degrees, and flip it over. *Do not fan the paper.* Return the stack of paper to the tray.

 **NOTE:** Fanning the paper introduces static electricity. Instead of fanning the paper, flex the stack by holding it at each end and bringing the ends up to form a U shape. Then, rotate the ends down to reverse the U shape. Next, hold each side of the stack of paper, and repeat this process. This process releases individual sheets without introducing static electricity. Straighten the paper stack against a table before returning it to the tray.

Figure 9-5 Technique for flexing the paper stack



-
2. Use only paper that meets HP specifications for this printer.
3. Verify that the humidity in the room is within specifications for this printer, and that paper is being stored in unopened packages. Most reams of paper are sold in moisture-proof wrapping to keep paper dry.

In high-humidity environments, paper at the top of the stack in the tray can absorb moisture, and it might have a wavy or uneven appearance. If this happens, remove the top 5 to 10 sheets of paper from the stack.

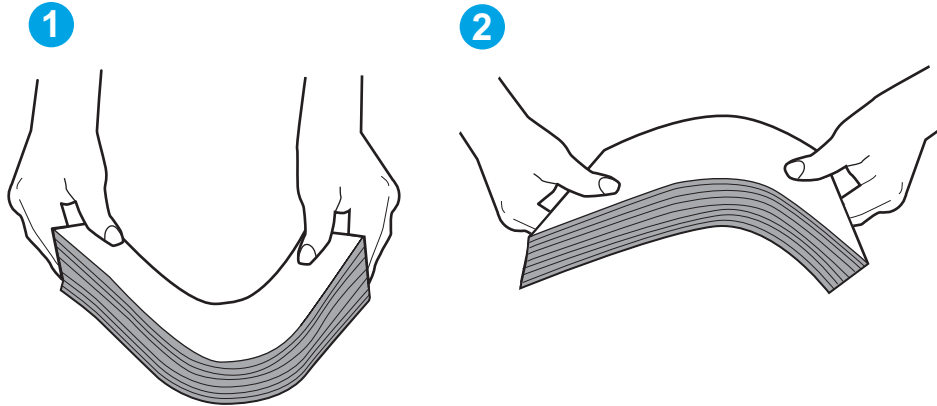
In low-humidity environments, excess static electricity can cause sheets of paper to stick together. If this happens, remove the paper from the tray, and flex the stack as described above.

-
-
-
4. Use paper that is not wrinkled, folded, or damaged. If necessary, use paper from a different package.

5. Make sure the tray is not overfilled by checking the stack-height markings inside the tray. If it is overfilled, remove the entire stack of paper from the tray, straighten the stack, and then return some of the paper to the tray.

The following images show examples of the stack-height markings in the trays for various printers. Most HP printers have markings similar to these. Also make sure that all sheets of paper are below the tabs near the stack-height marks. These tabs help hold the paper in the correct position as it enters the printer.

Figure 9-6 Stack-height markings

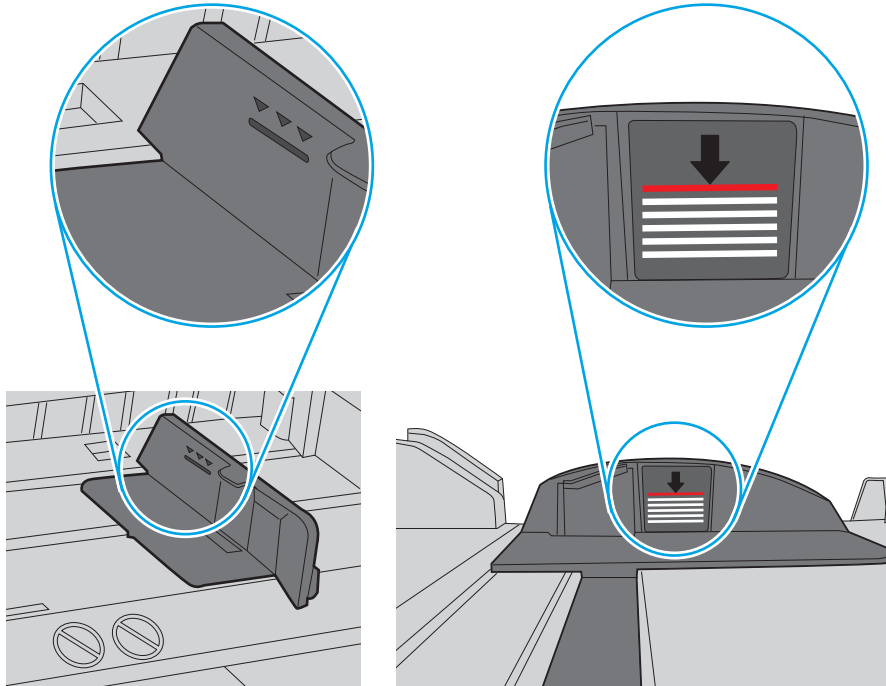
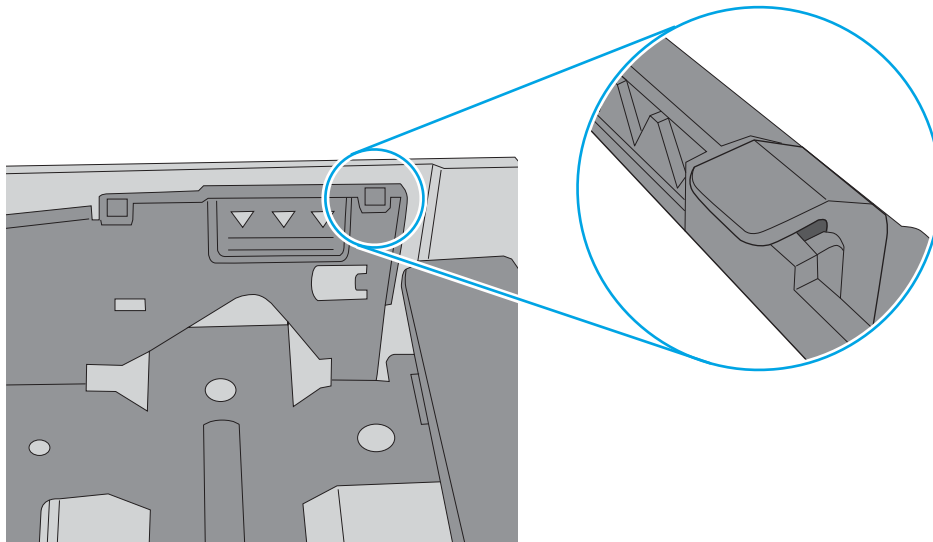

Figure 9-7 Tab for the paper stack



6. Make sure the paper guides in the tray are adjusted correctly for the size of paper. Adjust the guides to the appropriate indentation in the tray. The arrow on the tray guide should line up exactly with the marking on the tray.

 **NOTE:** Do not adjust the paper guides tightly against the paper stack. Adjust them to the indentations or markings in the tray.

The following images show examples of the paper-size indentations in the trays for various printers. Most HP printers have markings similar to these.

Figure 9-8 Size markings for Tray 1 or the multipurpose tray

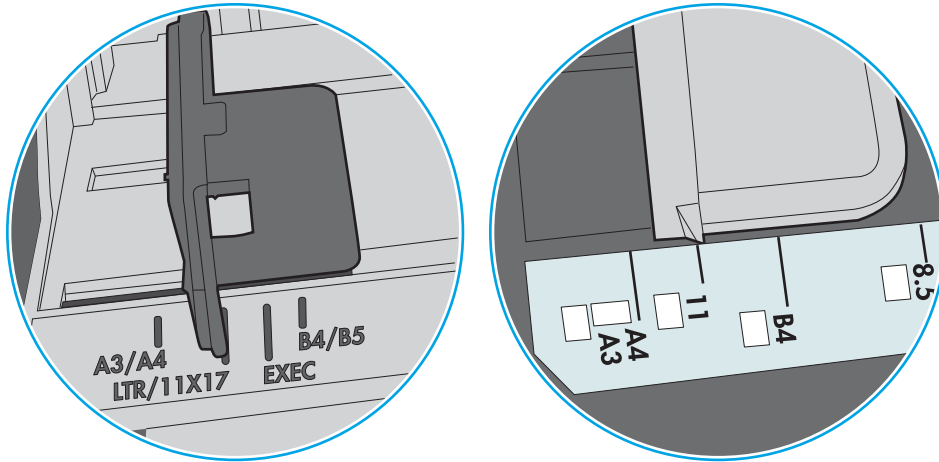
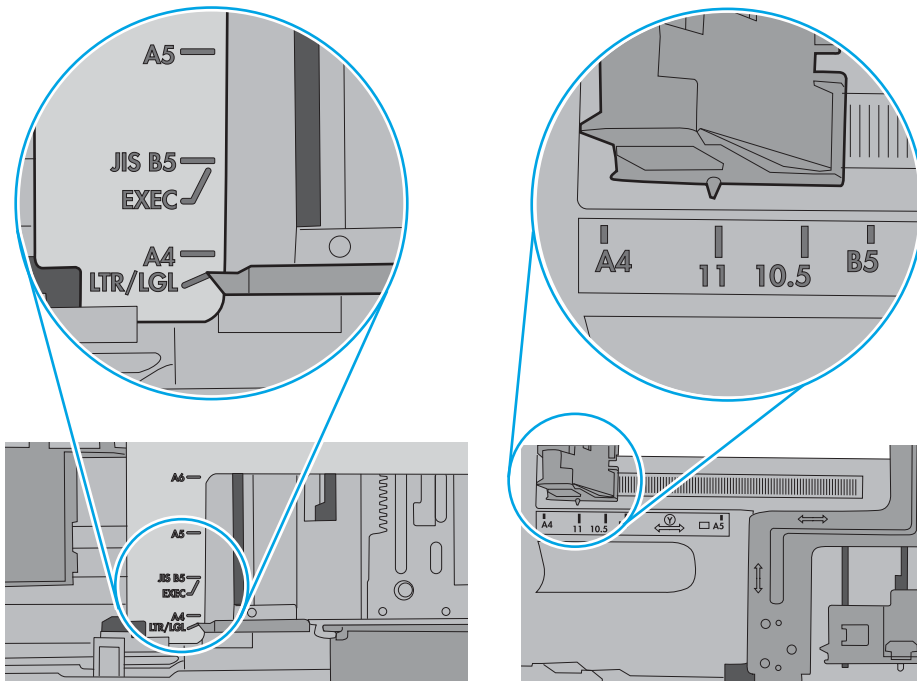



Figure 9-9 Size markings for cassette trays



7. Make sure the printing environment is within recommended specifications.

The document feeder jams, skews, or picks up multiple sheets of paper

 **NOTE:** This information applies to MFP printers only.

- The original might have something on it, such as staples or self-adhesive notes, that must be removed.
- Check that all rollers are in place and that the roller-access cover inside the document feeder is closed.
- Make sure that the top document-feeder cover is closed.
- The pages might not be placed correctly. Straighten the pages and adjust the paper guides to center the stack.
- The paper guides must be touching the sides of the paper stack to work correctly. Make sure that the paper stack is straight and the guides are against the paper stack.
- The document feeder input tray or output bin might contain more than the maximum number of pages. Make sure the paper stack fits below the guides in the input tray, and remove pages from the output bin.
- Verify that there are no pieces of paper, staples, paper clips, or other debris in the paper path.
- Clean the document-feeder rollers and the separation pad. Use compressed air or a clean, lint-free cloth moistened with warm water. If misfeeds still occur, replace the rollers.
- From the Home screen on the printer control panel, scroll to and touch the [Supplies](#) button. Check the status of the document-feeder kit, and replace it if necessary.

Clear paper jams

Introduction

The following information includes instructions for clearing paper jams from the printer.

- [Paper jam locations](#)
- [Auto-navigation for clearing paper jams](#)
- [Experiencing frequent or recurring paper jams?](#)
- [Clear paper jams in the document feeder](#)
- [Clear paper jams in Tray 1](#)
- [Clear paper jams in Tray 2](#)
- [Clear paper jams in Tray 3](#)
- [Clear paper jams in the output bin](#)
- [Clear paper jams in the duplexer](#)
- [Clear paper jams in the 3x550-sheet trays](#)
- [Clear paper jams in the 4,000-sheet high-capacity input \(HCI\) tray](#)
- [Clear paper jams in the inner finisher \(785zs model only\)](#)
- [Clear staple jams \(785zs model only\)](#)

Paper jam locations

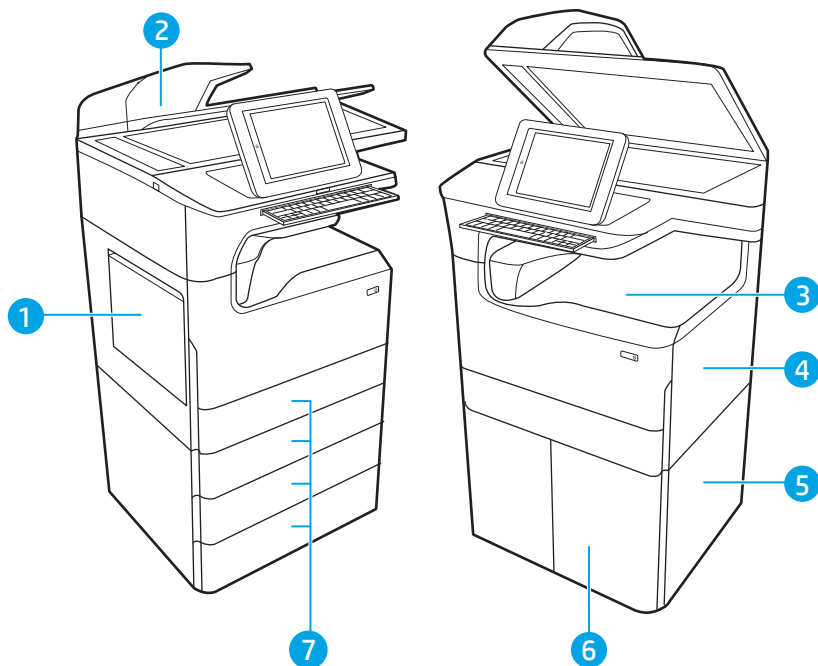

1	Tray 1 and left door
2	Document feeder
3	Output bin or inner finisher (785zs model only)
4	Right door (duplexer)
5	Lower right door
6	4,000-sheet HCI feeder
7	550-sheet trays

Auto-navigation for clearing paper jams

The auto-navigation feature assists in clearing jams by providing step-by-step instructions on the control panel. When you complete a step, the printer displays instructions for the next step until you have completed all steps in the procedure.

Experiencing frequent or recurring paper jams?

To reduce the number of paper jams, try these solutions.



NOTE: To see a video that demonstrates how to load paper in a way that reduces the number of paper jams, click [here](#).

1. Use only paper that meets HP specifications for this printer.
2. Use paper that is not wrinkled, folded, or damaged. If necessary, use paper from a different package.
3. Use paper that has not previously been printed or copied on.
4. Make sure the tray is not overfilled. If it is, remove the entire stack of paper from the tray, straighten the stack, and then return some of the paper to the tray.
5. Make sure the paper guides in the tray are adjusted correctly for the size of paper. Adjust the guides so they are touching the paper stack without bending it.
6. Make sure that the tray is fully inserted in the printer.
7. If you are printing on heavy, embossed, or perforated paper, use the manual feed feature and feed sheets one at a time.
8. Open the [Trays](#) menu on the printer control panel. Verify that the tray is configured correctly for the paper type and size.
9. Make sure the printing environment is within recommended specifications.

Clear paper jams in the document feeder

The following information describes how to clear paper jams in the document feeder. When a jam occurs, the control panel displays an error message and an animation that assist in clearing the jam.

1. Lift the latch to release the document-feeder cover.

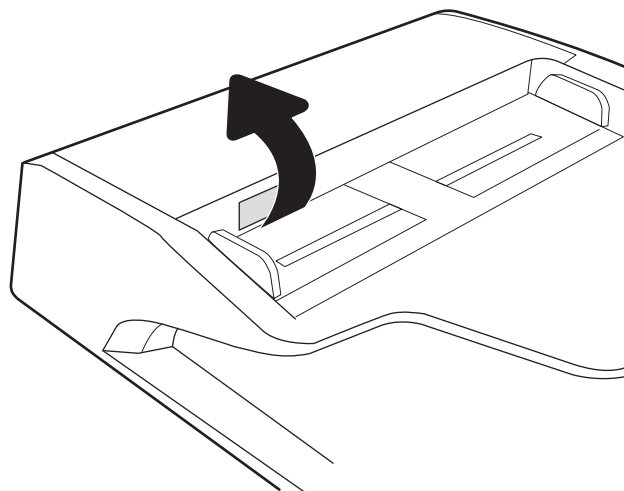

2. Open the document-feeder cover.

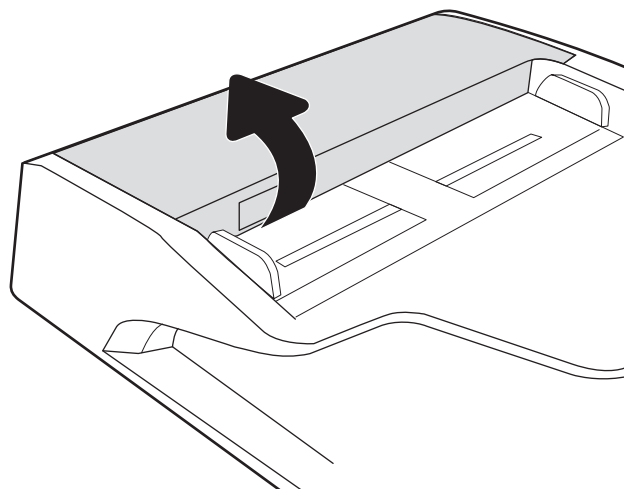

3. Remove any jammed paper.

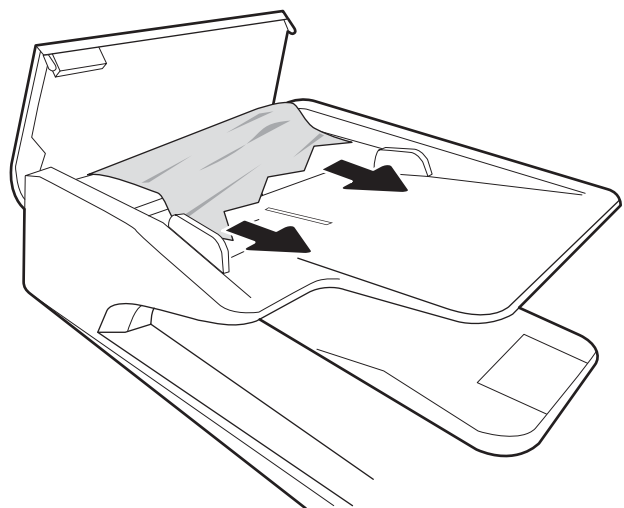

4. Lift the scanner lid and remove any jammed paper from the bottom of the scanner lid.

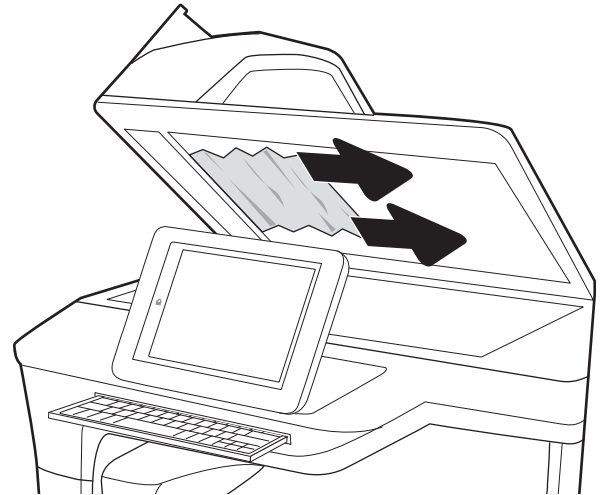

5. Close the scanner lid and the document feeder cover.

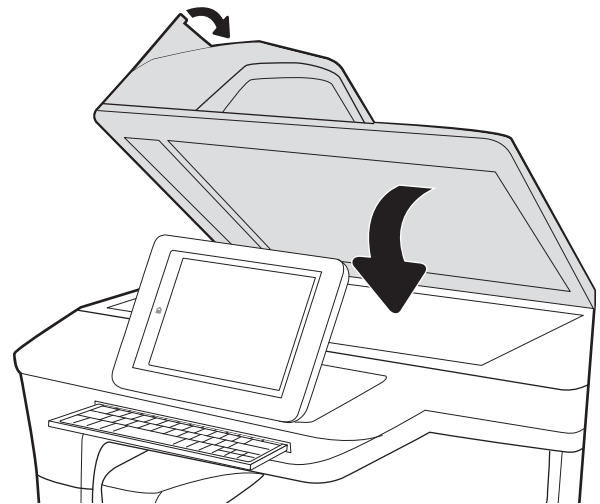

6. If there are remaining pages still in the printer, instructions on how to clear the remaining pages will display on the control panel.

 **NOTE:** To avoid jams, make sure the guides in the document-feeder input tray are adjusted tightly against the document. Remove all staples and paper clips from original documents.

 **NOTE:** Original documents that are printed on heavy, glossy paper can jam more frequently than originals that are printed on plain paper.

Clear paper jams in Tray 1

The following information describes how to clear a paper jam in Tray 1. When a jam occurs, the control panel displays an error message and an animation that assist in clearing the jam.

1. If jammed paper is visible in Tray 1, clear the jam by gently pulling the paper straight out.

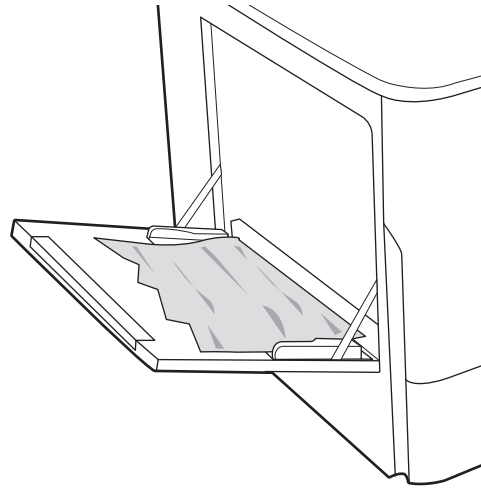

2. Close Tray 1.

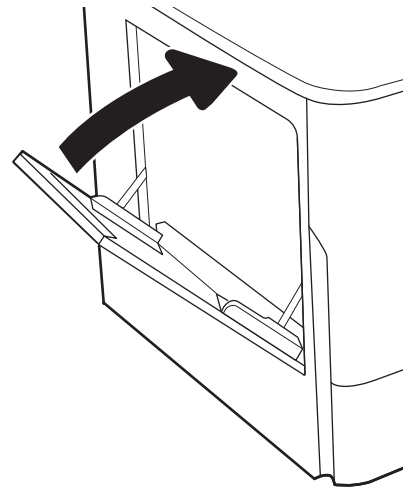

3. Open the left door.

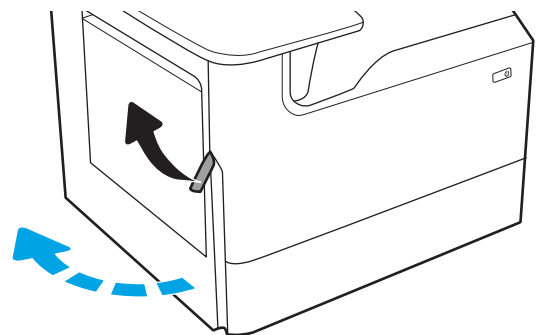

4. Pull any jammed paper straight out.

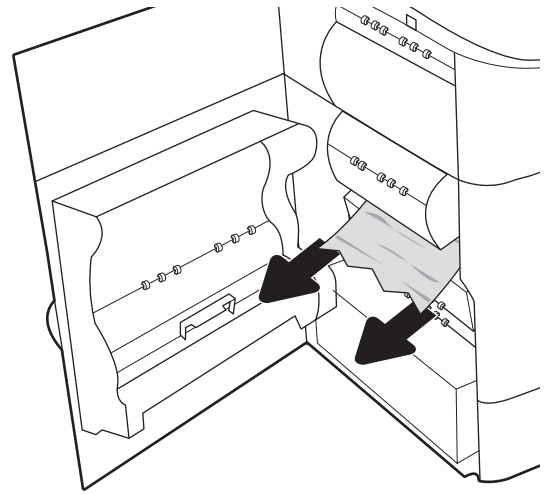

5. If no jammed paper is visible, pull the service fluid container out.

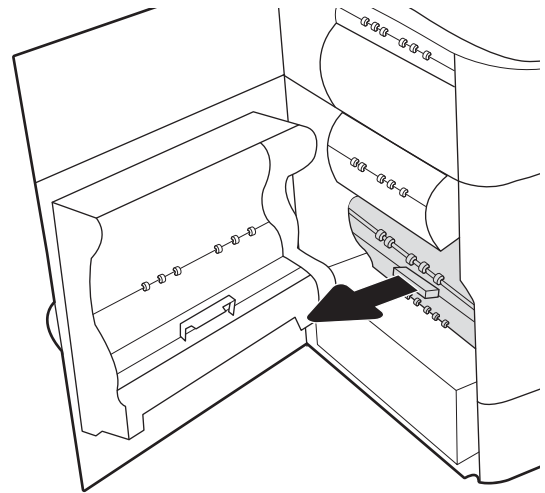

6. Pull any jammed paper straight out.

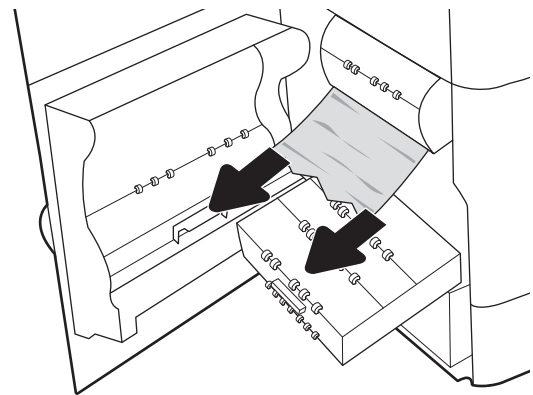

7. Push the service fluid container into the printer.

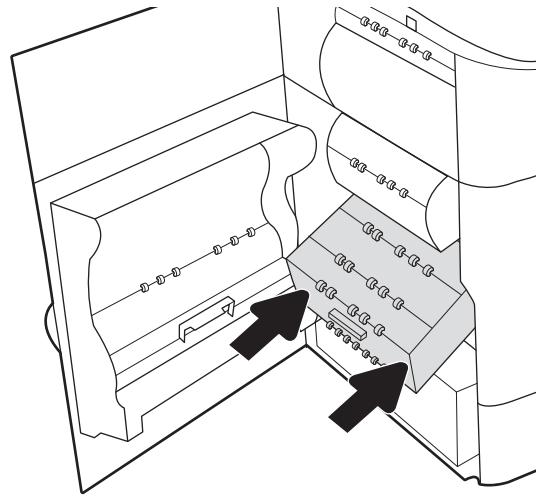

8. Close the left door.

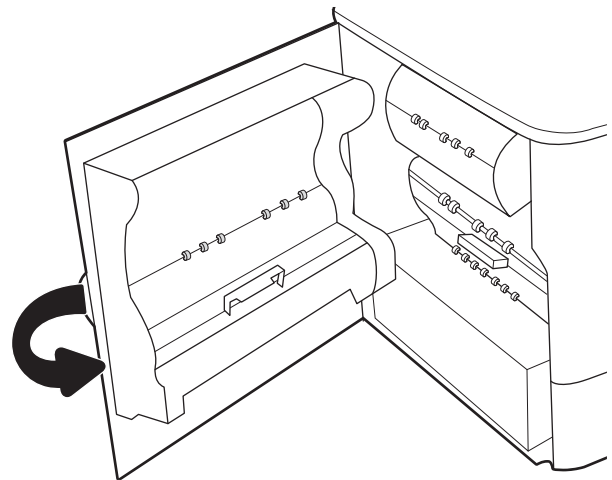

9. If there are remaining pages still in the printer, instructions on how to clear the remaining pages will display on the control panel.

Clear paper jams in Tray 2

The following information describes how to clear a paper jam in Tray 2. When a jam occurs, the control panel displays an error message and an animation that assist in clearing the jam.

1. Open the tray.

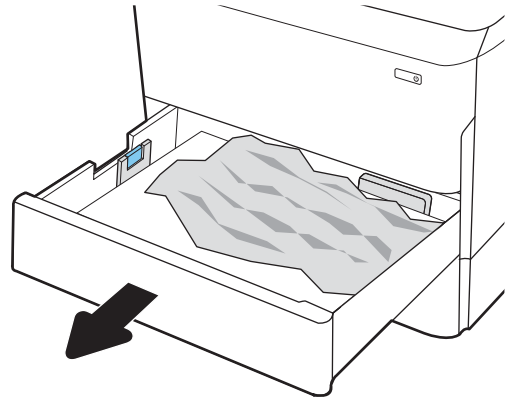

2. Remove the jammed paper from the feed rollers inside the printer. First pull the paper to the left, and then pull it forward to remove it.

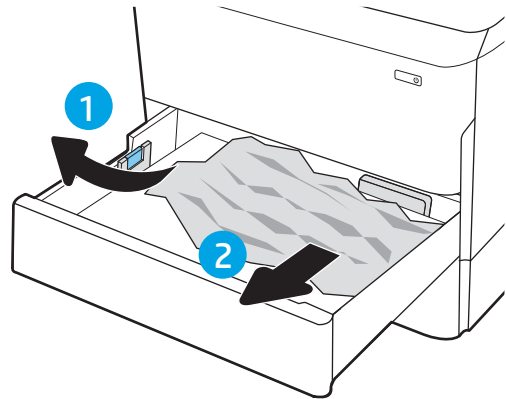

3. Open the right door.

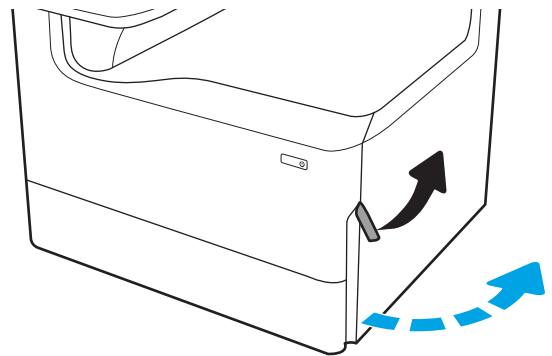

4. Remove any jammed paper.

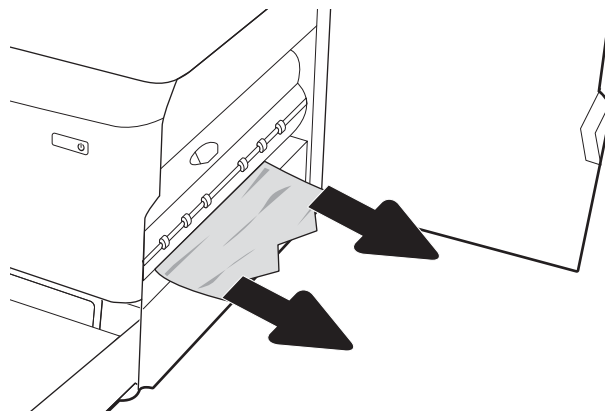

5. If no jammed paper is visible, remove the duplexer.

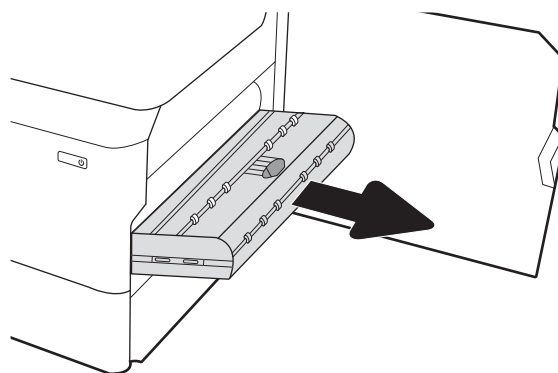

6. Pull any jammed paper straight out.

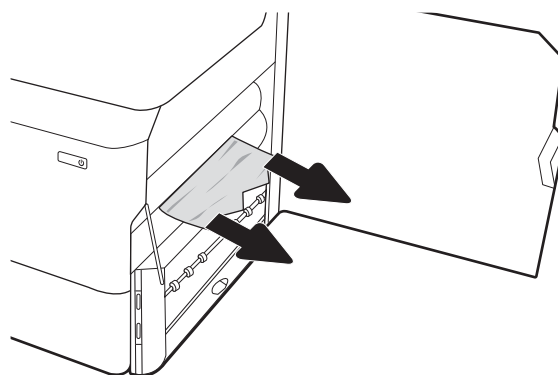

7. Reinstall the duplexer.

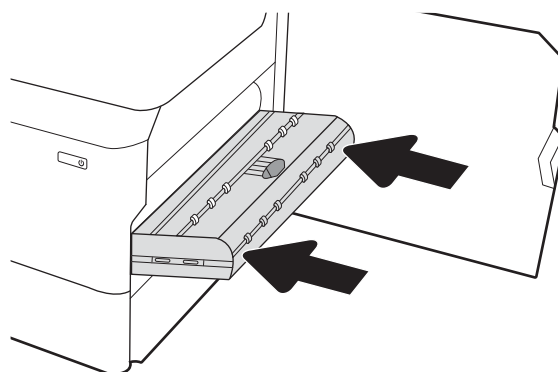

8. Close the right door.

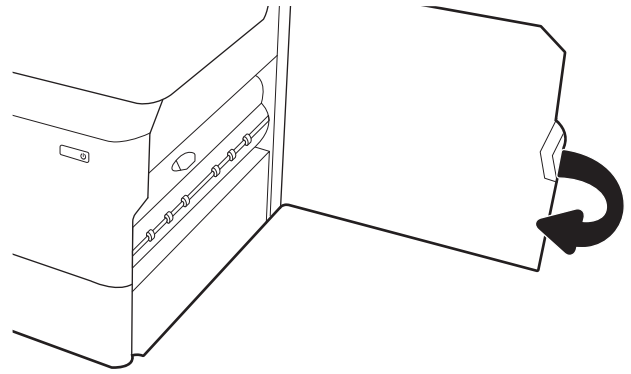

9. Close the tray.

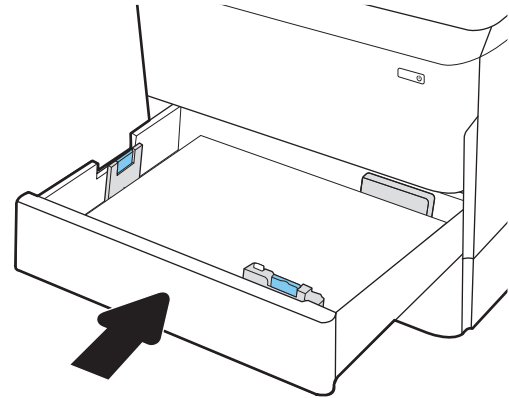

10. If there are remaining pages still in the printer, instructions on how to clear the remaining pages will display on the control panel.

Clear paper jams in Tray 3

Use the following procedure to check for paper in all possible jam locations related to the 550-sheet trays. When a jam occurs, the control panel displays an error message and an animation that assist in clearing the jam.

 **NOTE:** The procedure to clear paper jams from the 1x550-sheet tray with cabinet stand is the same as for the table-top 1x550-sheet tray. Only the table-top tray is shown here.

1. Open the tray.

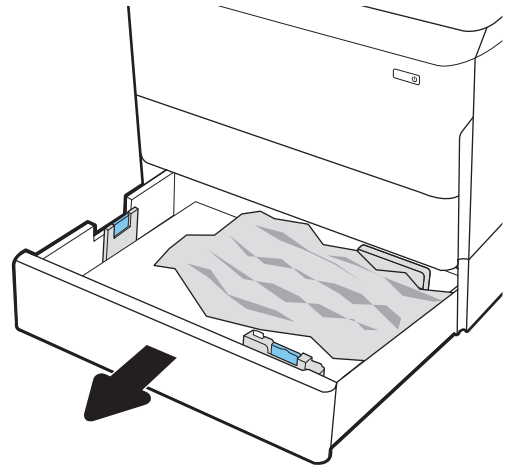

2. Remove the jammed paper from the feed rollers inside the printer. First pull the paper to the left, and then pull it forward to remove it.

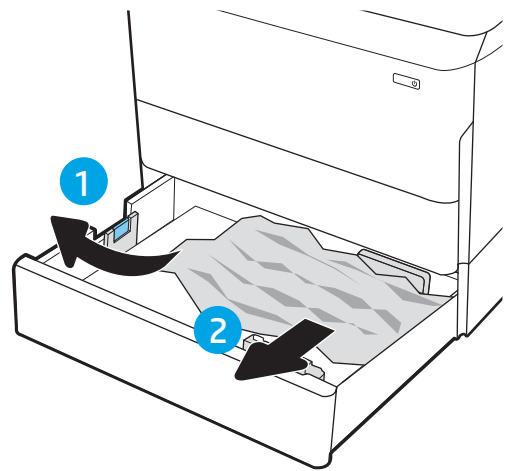

3. Open the right door and the lower-right door.

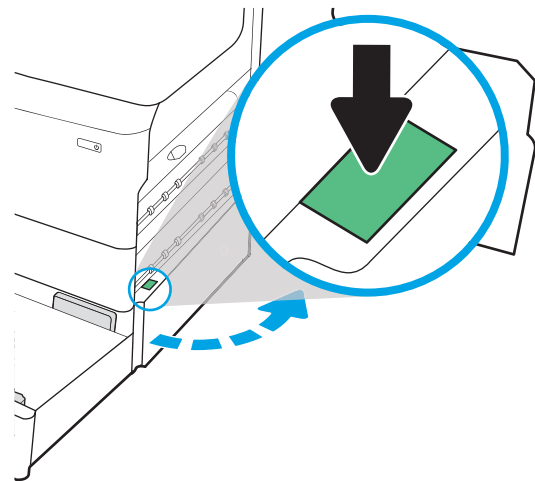

4. Gently pull out any jammed paper.

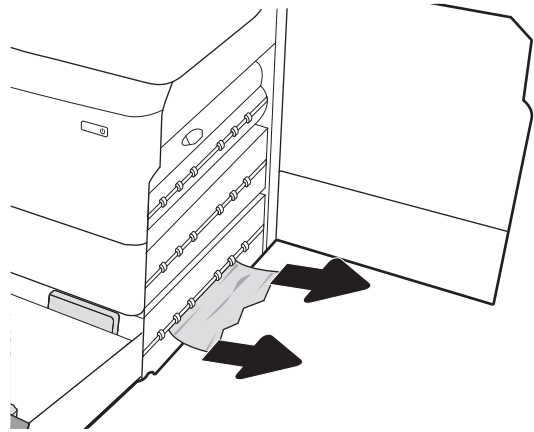

5. If no jammed paper is visible, remove the duplexer.

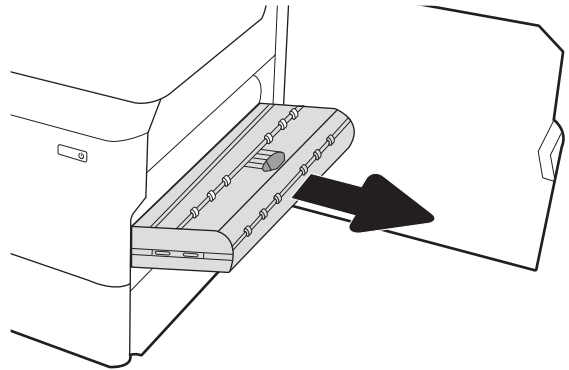

6. Pull any jammed paper straight out.

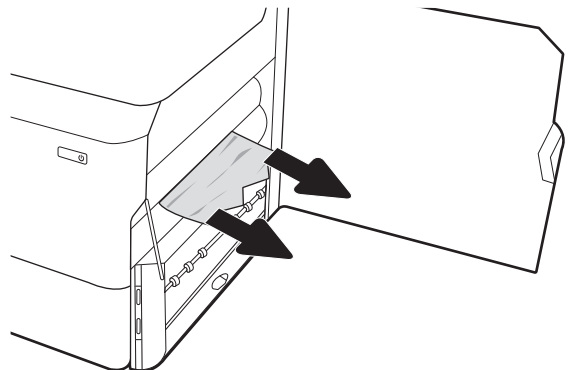

7. Reinstall the duplexer.

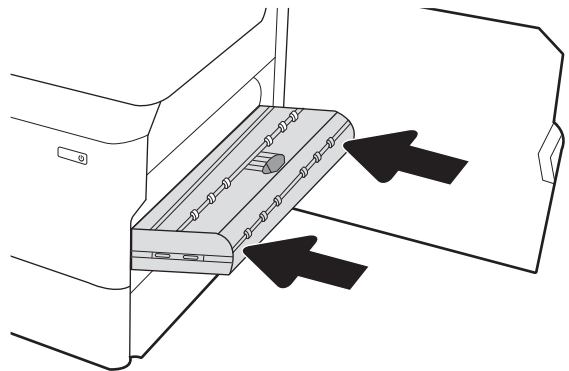

8. Close the lower-right door and the right door, and then close the tray.

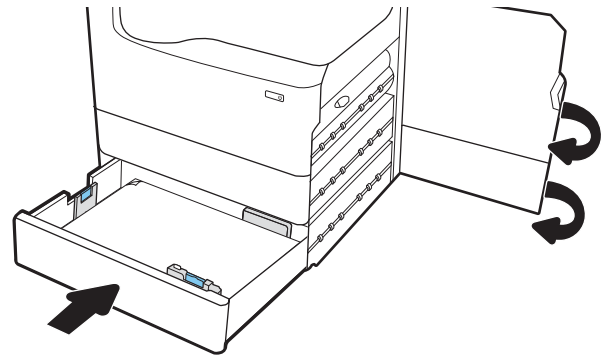

9. If there are remaining pages still in the printer, instructions on how to clear the remaining pages will display on the control panel.

Clear paper jams in the output bin

The following information describes how to clear a paper jam in the output bin. When a jam occurs, the control panel displays an error message and an animation that assist in clearing the jam.

1. If paper is visible in the output bin, grasp the leading edge and remove it.



2. Open the left door.

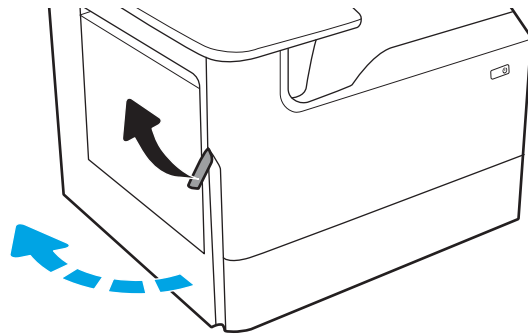

3. Remove any jammed paper.

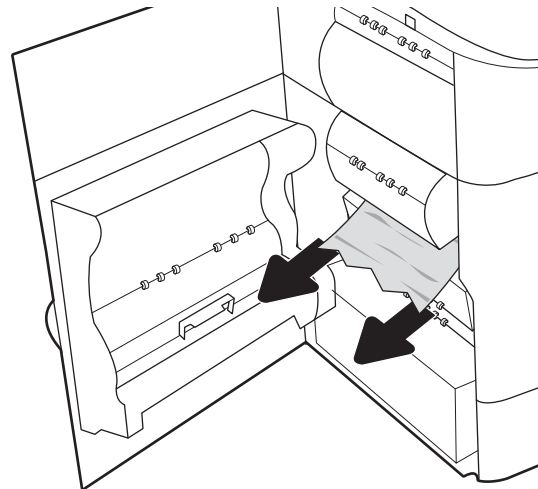

4. Close the left door.

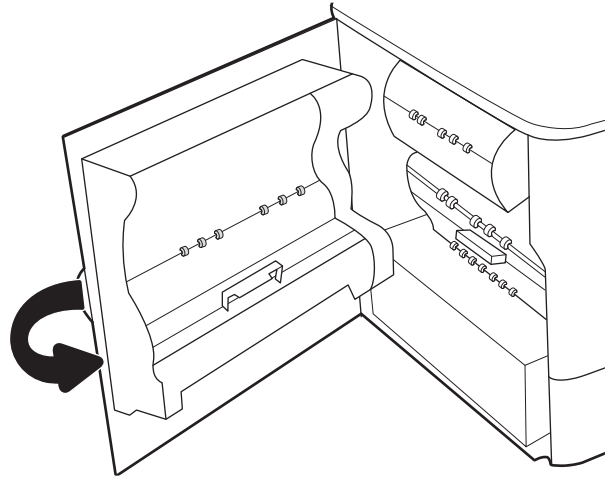

5. If there are remaining pages still in the printer, instructions on how to clear the remaining pages will display on the control panel.

Clear paper jams in the duplexer

Use the following procedure to check for paper in all possible jam locations in the automatic duplexer. When a jam occurs, the control panel displays an error message and an animation that assist in clearing the jam.

1. Open the right door.

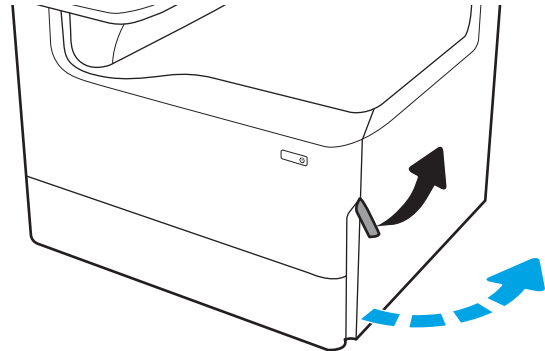

2. Remove any jammed paper.

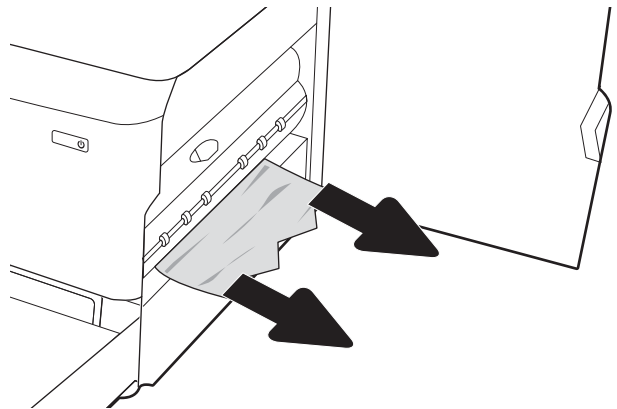

3. If no jammed paper is visible, remove the duplexer.

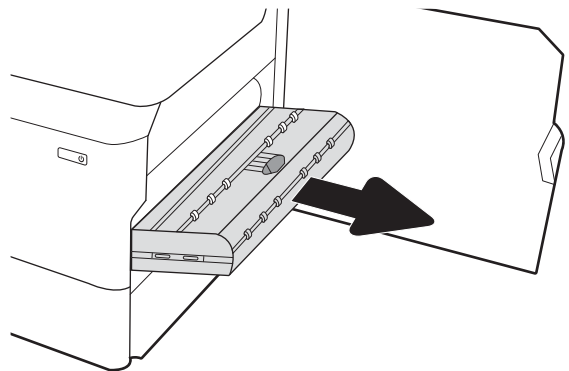

4. Pull any jammed paper straight out.

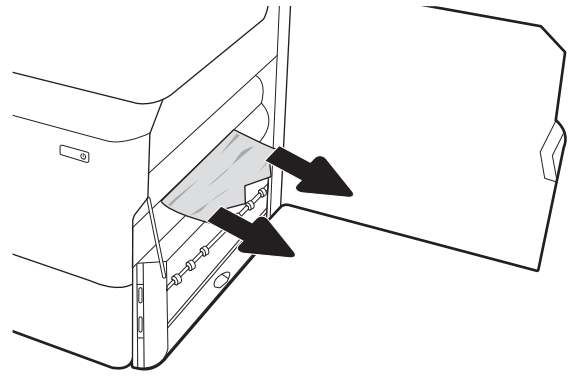

5. Reinstall the duplexer.

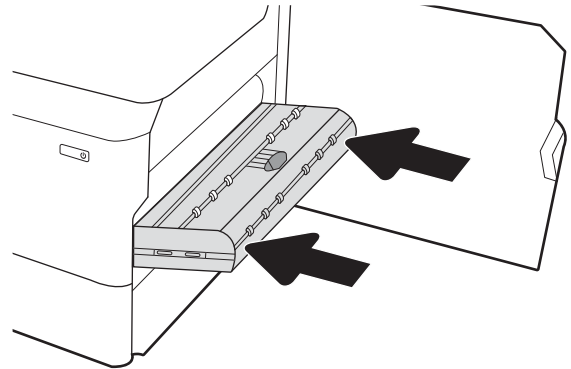

6. Close the right door.

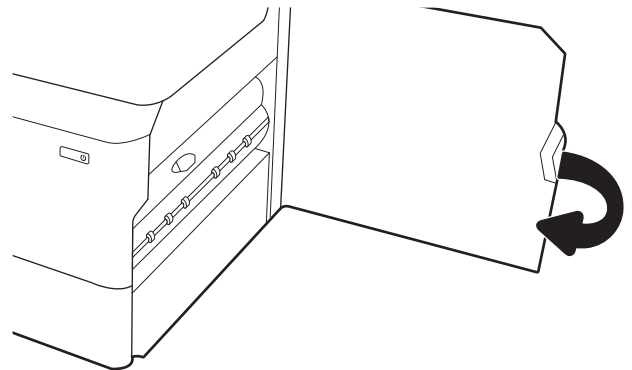

7. If there are remaining pages still in the printer, instructions on how to clear the remaining pages will display on the control panel.

Clear paper jams in the 3x550-sheet trays

Use the following procedure to check for paper in all possible jam locations related to the 3x550-sheet trays. When a jam occurs, the control panel displays an error message and an animation that assist in clearing the jam.

1. Open one of the trays.

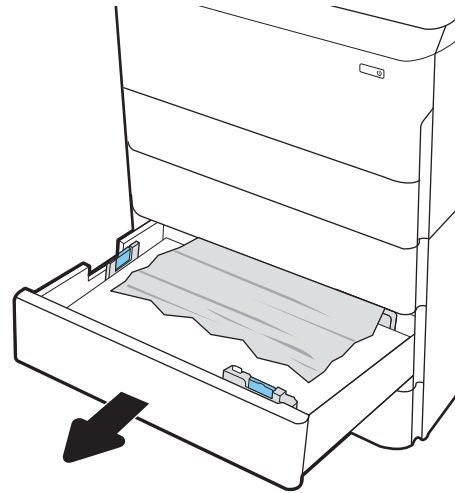

2. Remove the jammed paper from the feed rollers inside the printer. First pull the paper to the left, and then pull it forward to remove it.

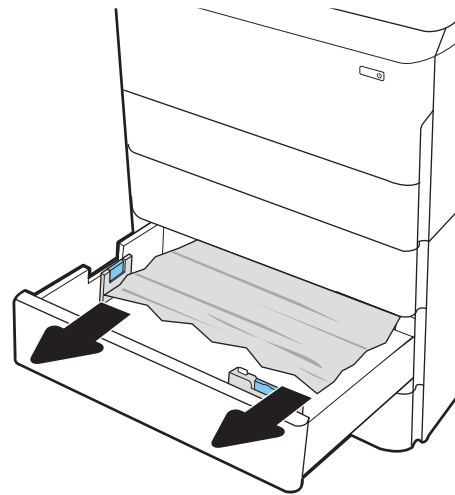

3. Open the right door and the lower-right door.

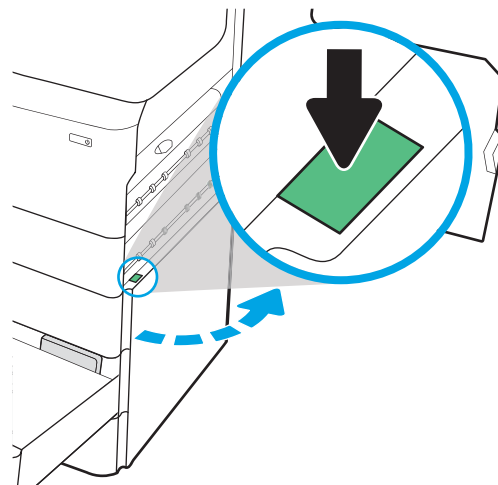

4. Gently pull out any jammed paper.

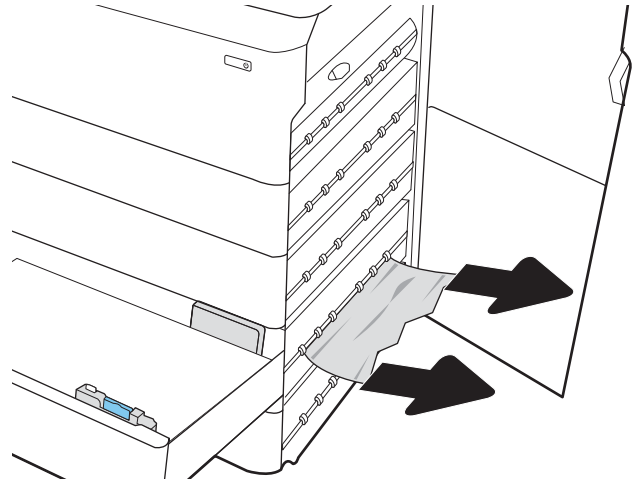

5. If no jammed paper is visible, remove the duplexer.

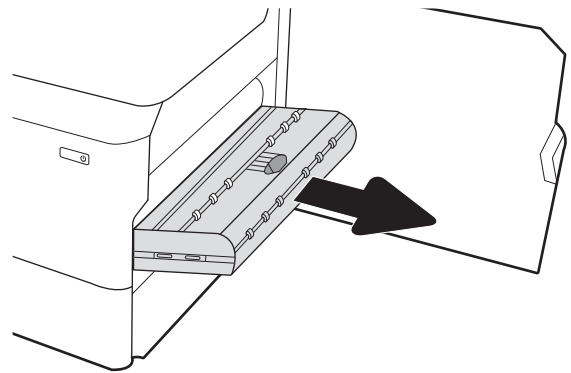

6. Pull any jammed paper straight out.

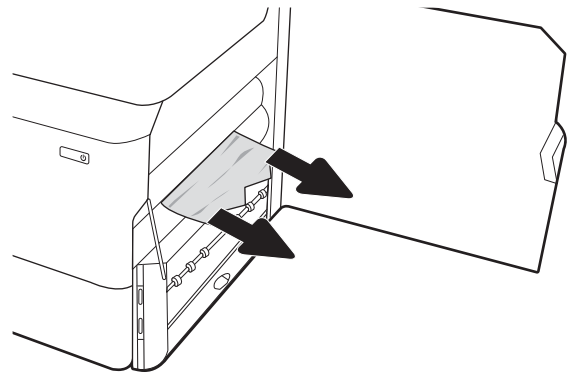

7. Reinstall the duplexer.

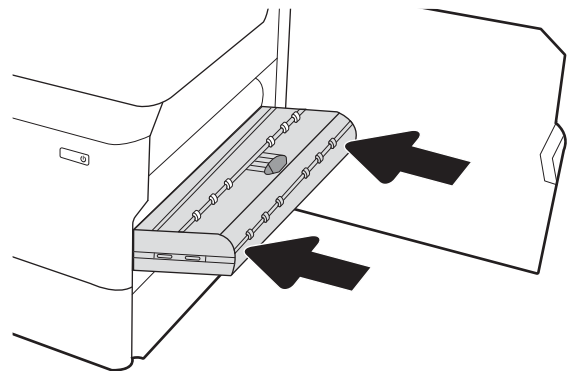

8. Close the right door and the lower-right door, and then close the tray.

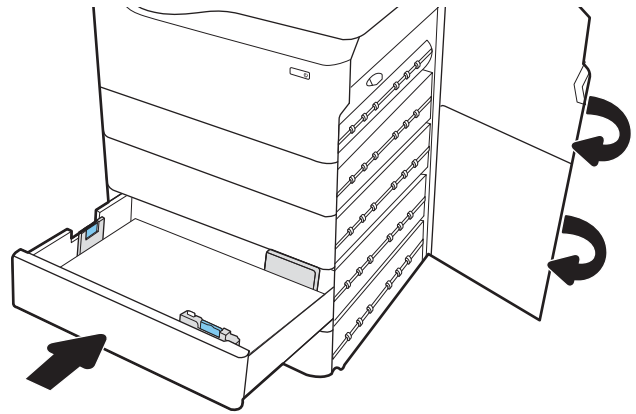

9. If there are remaining pages still in the printer, instructions on how to clear the remaining pages will display on the control panel.

Clear paper jams in the 4,000-sheet high-capacity input (HCI) tray

The following information describes how to clear a paper jam in the 4,000-sheet high-capacity tray. When a jam occurs, the control panel displays an error message and an animation that assist in clearing the jam.

1. Open the left high-capacity input tray.

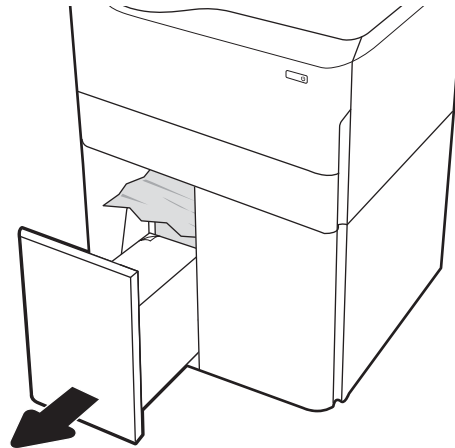

2. Remove the jammed paper from the feed rollers inside the printer. First pull the paper to the left, and then pull it forward to remove it.

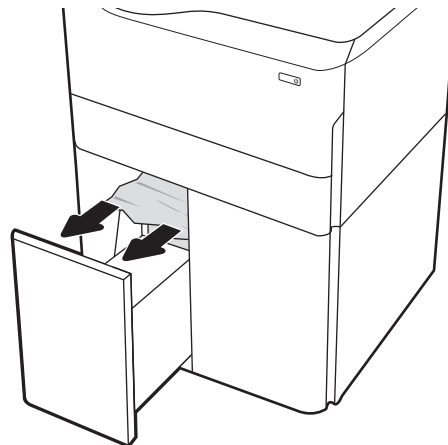

3. Close the left tray and open the right high-capacity input tray.

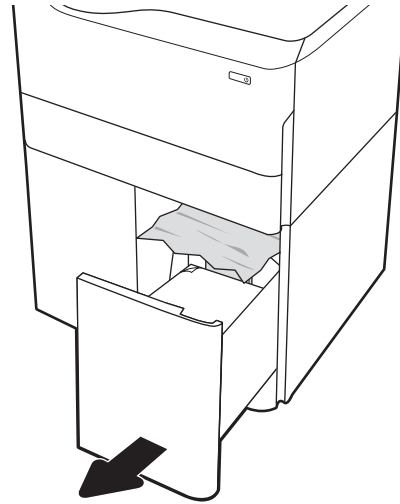

4. Remove the jammed paper from the feed rollers inside the printer. First pull the paper to the left, and then pull it forward to remove it.

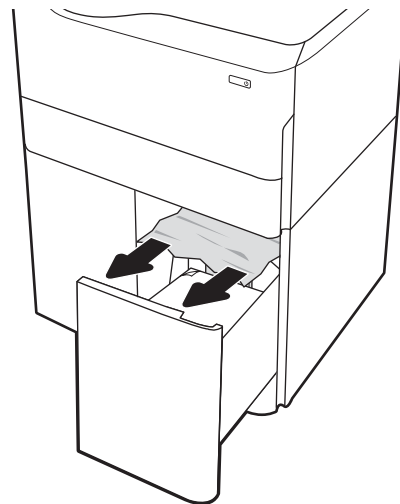

5. Open the right door and the lower right door.

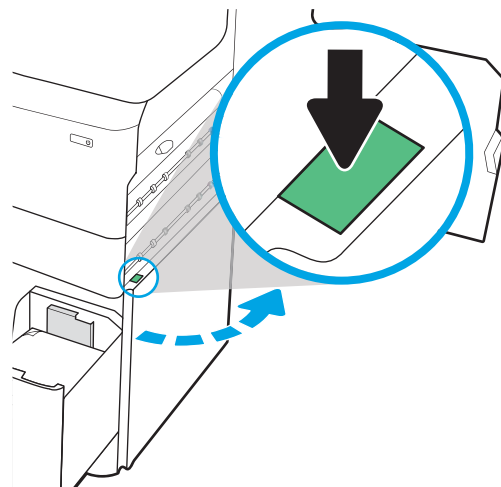

6. Remove any damaged sheets.

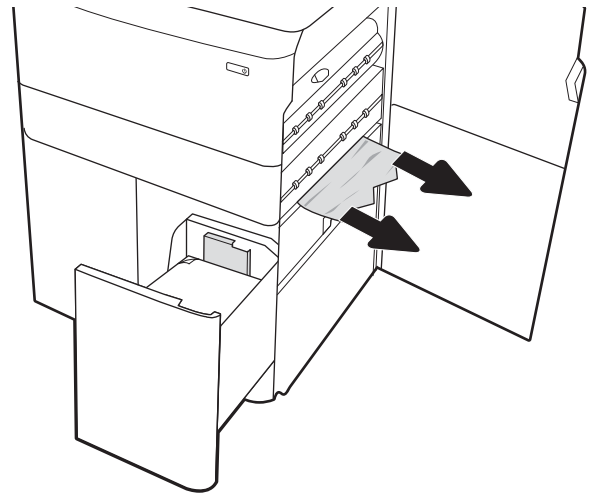

7. If no jammed paper is visible, remove the duplexer.

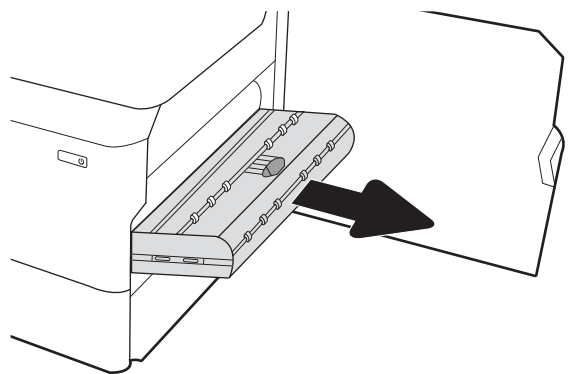

8. Pull any jammed paper straight out.

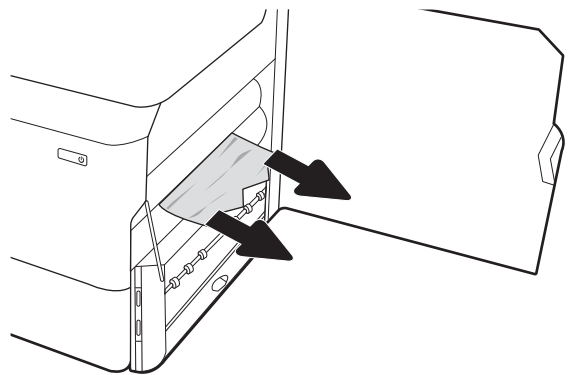

9. Reinstall the duplexer.

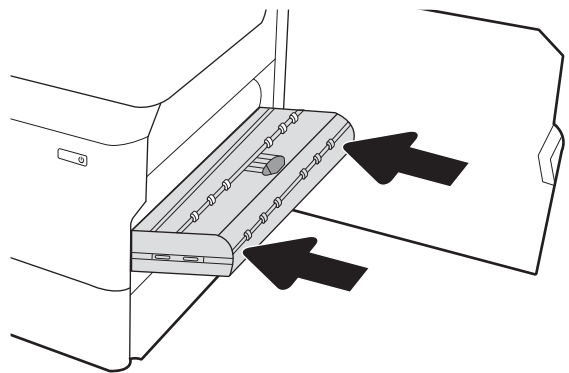

10. In the lower right door area, use the green handle to pull out the HCl jam cassette.

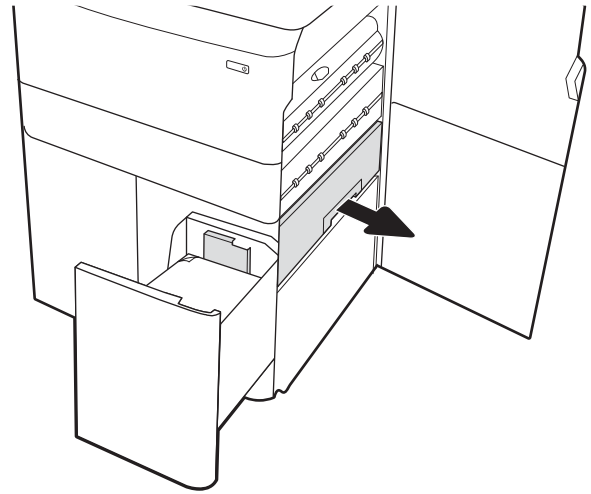

11. Remove any jammed paper from the jam cassette area.

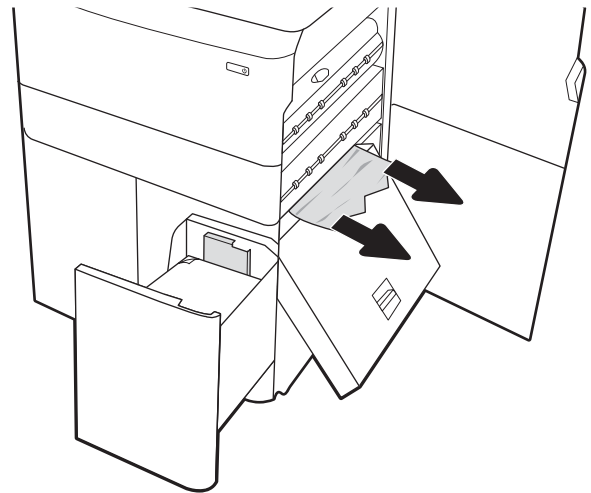

12. Use the green handle to open the top of the HCl jam cassette, and remove any jammed paper.

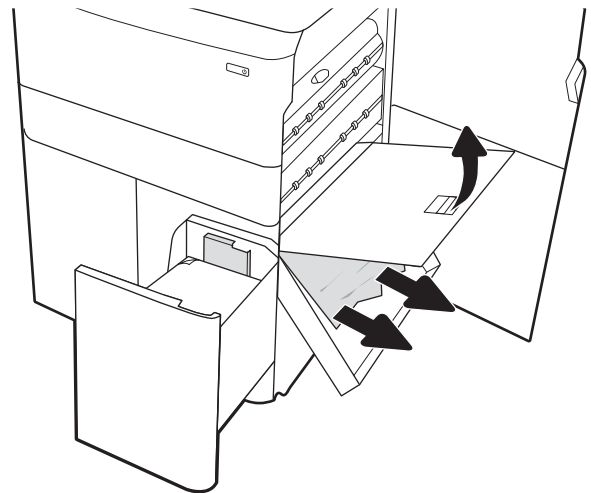

13. Close the jam cassette, and then reinstall it into the printer.

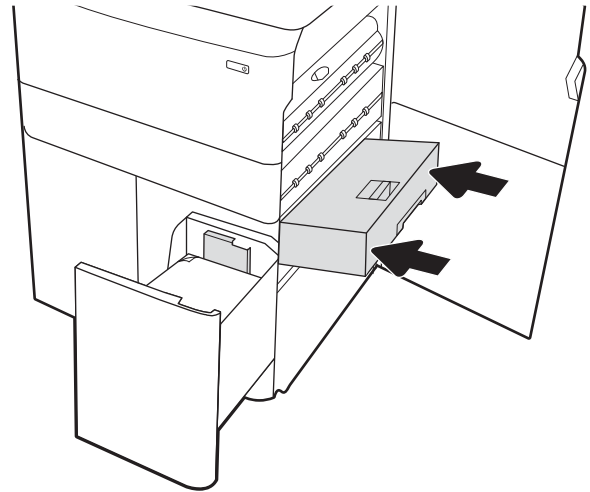

14. Close the right door and the lower right door, and then close the right tray.

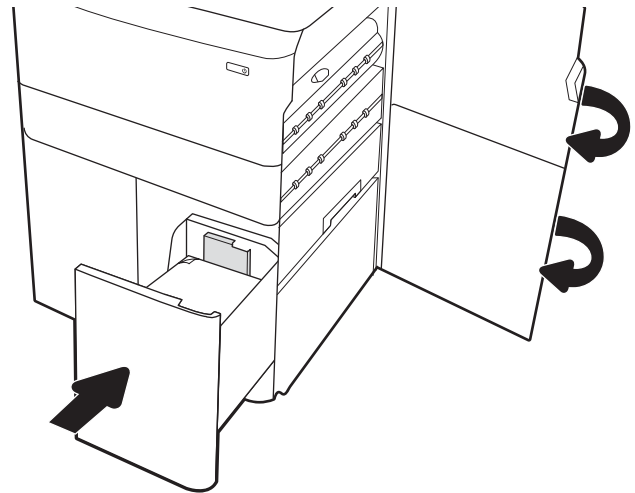

15. If there are remaining pages still in the printer, instructions on how to clear the remaining pages will display on the control panel.

Clear paper jams in the inner finisher (785zs model only)

The following information describes how to clear a paper jam in the inner finisher. When a jam occurs, the control panel displays an error message and an animation that assist in clearing the jam.

1. Remove any jammed paper from the inner finisher bins.



2. Open the left door. If jammed paper is visible inside the jam-access door, pull it straight out to remove it.

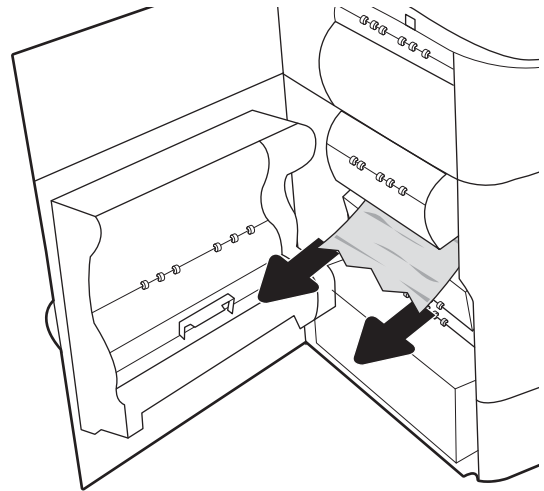

3. Close the left door.

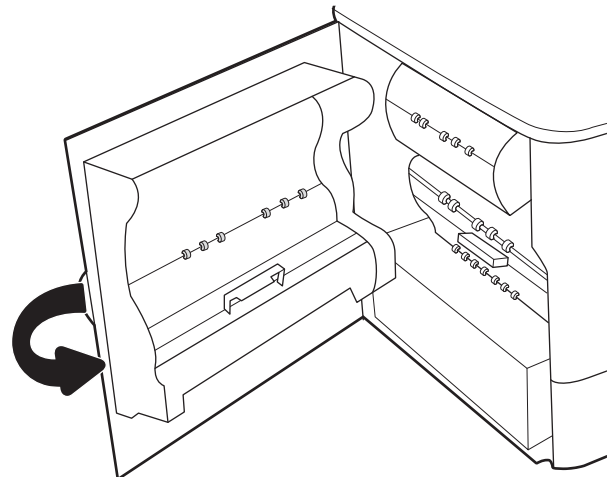

4. If there are remaining pages still in the printer, instructions on how to clear the remaining pages will display on the control panel.

Clear staple jams (785zs model only)

The following information describes how to clear a staple jam. When a jam occurs, the control panel displays an error message and an animation that assist in clearing the jam.

1. Open the stapler door.

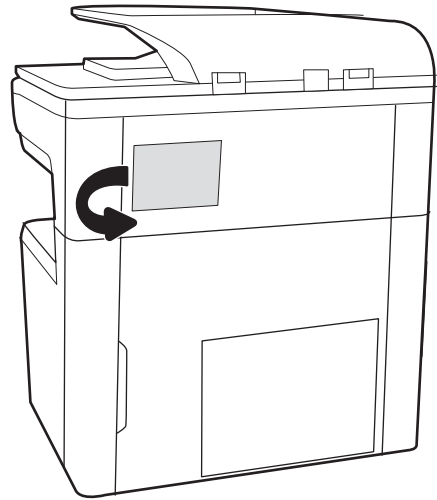

2. Pull the colored handle on the staple cartridge, and then pull the staple cartridge straight out.

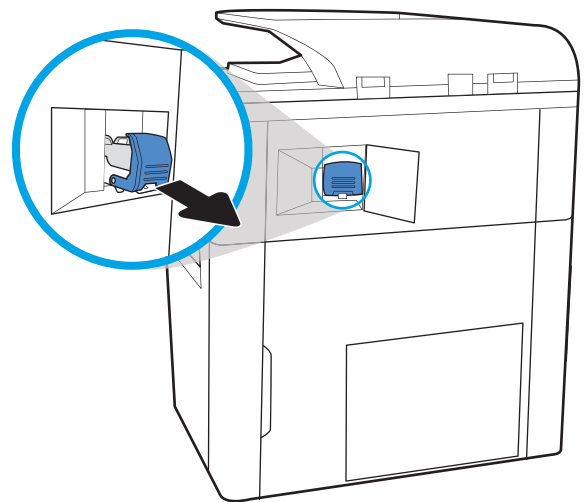

3. Lift up on the small lever at the back of the staple cartridge to separate the staple cartridge from the holder, and then remove any jammed staples.

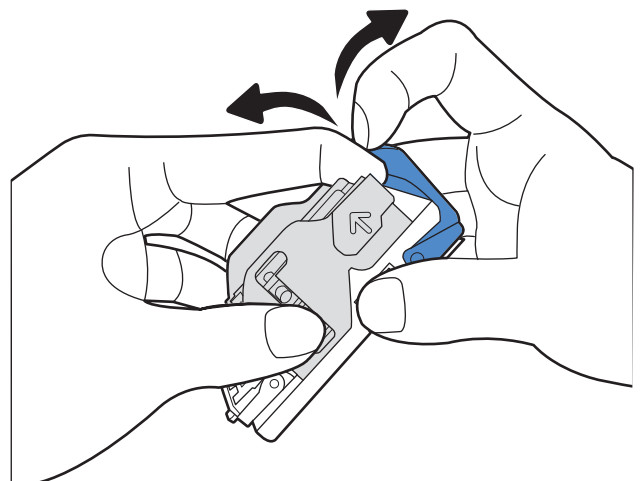

4. Close the lever at the back of the staple cartridge. Be sure that it snaps into place.

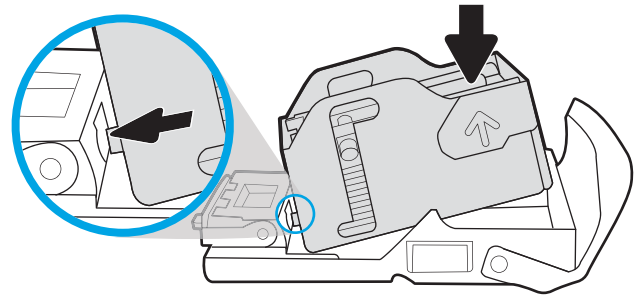

5. Insert the staple cartridge into the stapler and push on the colored handle until it snaps into place.

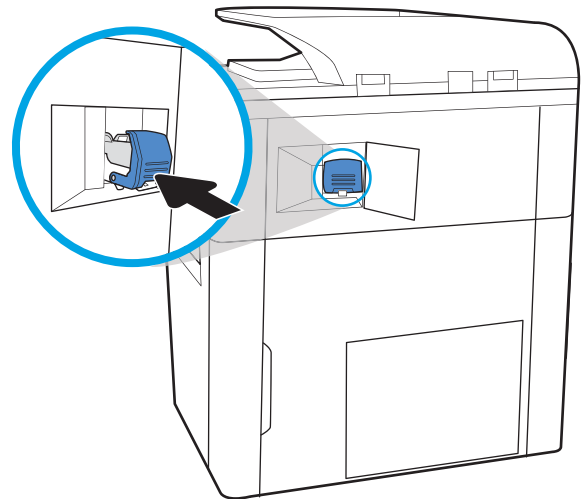

6. Close the stapler door.

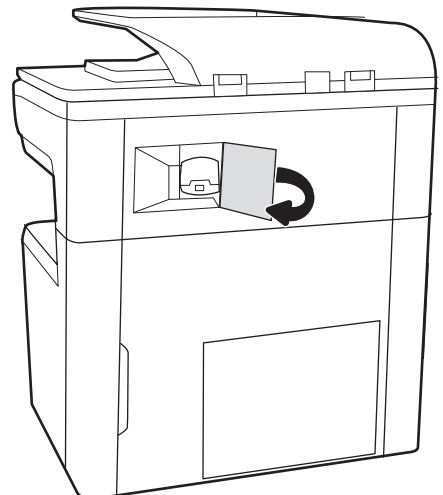

Improve print quality

Introduction

Occasionally, the printer might have print-quality issues such as streaks or fading, missing black or other colors, blurred or fuzzy text, and ink streaks or smears. Try the following solutions in the order presented. When one of the solutions resolves the issue, there is no need to continue with the other procedures.





NOTE: If the issue only occurs on copies, see “Improve copy image quality.”

- [Check the cartridge status](#)
- [Update the printer firmware](#)
- [Change the print quality setting](#)
- [Print from a different software program](#)
- [Check paper and quality settings](#)
- [Check grayscale and black settings](#)
- [Adjust color settings \(Windows\)](#)
- [Check paper and the printing environment](#)
- [Visually inspect the cartridge](#)
- [Clean the printer](#)
- [Try a different print driver](#)

Check the cartridge status

Print quality problems can occur when using a cartridge that is at its estimated end of life. Follow these steps to check the estimated life remaining in the cartridges and if applicable, the status of other replaceable maintenance parts.

Step one: Check the control panel

- ▲ Check the control panel to see whether it displays any messages or warning   icons. Select the icon to view the message. Replace the cartridge if the message indicates that a cartridge needs to be replaced or is in the very low condition.



NOTE: If you would like more detailed information about the cartridge status before replacing the cartridge, continue to the next step.

Step two: Check supplies status

1. From the Home screen on the printer control panel, select [Reports](#).
2. Select the [Configuration/Status Pages](#) menu and then select the [Supplies Status Page](#).
3. Select [View](#) to view the report on the control panel, or select [Print](#) to print the page.
4. Look at the Supplies Status Page to check the percent of life remaining for the cartridges and, if applicable, the status of other replaceable maintenance parts.

- The Supplies Status Page indicates when a supply level is very low. After an HP supply has reached the very low threshold, HP's premium protection warranty on that supply has ended.
- The cartridge does not need to be replaced now unless the print quality is no longer acceptable. Consider having a replacement available to install when print quality is no longer acceptable.
- If you determine that you need to replace a cartridge or other replaceable maintenance parts, the Supplies Status Page lists the genuine HP part numbers.

Update the printer firmware

Try updating the printer firmware. For more information, go to www.hp.com/support and select the option to **Get software and drivers**. Then follow the prompts to navigate to the firmware download for the printer.

Change the print quality setting

Complete the following steps to change the print quality setting on the printer control panel.



NOTE: The steps vary according to the type of control panel.

1. From the Home screen on the printer control panel, select **Settings**.
2. Open the following menus:
 - **Copy/Print** or **Print**
 - **Default print options**
 - **Quality Level**
3. Select the desired quality level: **General Office**, **Professional**, or **Presentation**.

Print from a different software program

Try printing from a different software program. If the page prints correctly, the problem is with the software program from which you were printing.

Check paper and quality settings

Check the print driver settings for paper and quality in the software program you are printing from, such as Microsoft® Word.

Windows

1. From the software program, select the **Print** option.
2. Select the printer, and then click the **Properties** or **Preferences** button.
3. Click the **Paper/Quality** tab.
4. From the **Paper Type** options, select the paper type that best describes your paper.
5. From the **Print Quality** options, select the quality or resolution setting that is appropriate for your print job.
6. Click the **OK** button to close the Document Properties dialog box. In the Print dialog box, click **Print** or **OK** to print the job.

OS X

1. Click the **File** menu, and then click the **Print** option.
2. In the **Printer** menu, select the printer.
3. In the drop-down list just below **Orientation**, select **Paper/Quality**.
4. From the **Media Type** options, select the paper type that best describes your paper.
5. From the **Print Quality** options, select the quality or resolution setting that is appropriate for your print job.
6. Click the **Print** button.

Check grayscale and black settings

Check the print driver settings for grayscale and black when printing to a color printer and the printed pages are grayscale or black when color was expected.

Windows

1. From the software program, select the **Print** option.
2. Select the printer, and then click the **Properties** or **Preferences** button.
3. Make sure that the **Print in Grayscale** option is turned off. Depending on your printer, the grayscale option could appear on the **Printing Shortcuts** tab and the **Color** tab.
4. Make sure that the **Print all text in black** option is turned off on the **Advanced** tab.
5. Click the **OK** button to close the Document Properties dialog box. In the Print dialog box, click **Print** or **OK** to print the job.

OS X

1. Click the **File** menu, and then click the **Print** option.
2. In the **Printer** menu, select the printer.
3. In the drop-down list just below **Orientation**, select **Color**.
4. Make sure that the **Print in Grayscale** option is turned off.
5. Select the triangle next to **Advanced** to expand the options. Make sure that the settings for **Text**, **Graphics**, and **Photo** are not set to **Black Only**.
6. Click the **Print** button.

Adjust color settings (Windows)

When printing from a software program, follow these steps if colors on the printed page do not match colors on the computer screen, or if the colors on the printed page are not satisfactory.

1. From the software program, select the **Print** option.
2. Select the printer, and then click the **Properties** or **Preferences** button.
3. On the **Advanced** tab or the **Color** tab, clear the **HP EasyColor** check box.
4. On the **Color** tab, select a color theme from the **Color Themes** drop-down list.

- **Default (sRGB):** This theme sets the printer to print RGB data in raw device mode. When using this theme, manage color in the software program or in the operating system for correct rendering.
 - **Vivid (sRGB):** The printer increases the color saturation in the midtones. Use this theme when printing business graphics.
 - **Photo (sRGB):** The printer interprets RGB color as if it were printed as a photograph using a digital mini lab. The printer renders deeper, more saturated colors differently than with the Default (sRGB) theme. Use this theme when printing photos.
 - **Photo (Adobe RGB 1998):** Use this theme with printing digital photos that use the AdobeRGB color space rather than sRGB. Turn off color management in the software program when using this theme.
 - **None:** No color theme is used.
 - **Custom Profile:** Select this option to use a custom input profile to accurately control color output (for example, to emulate a specific printer). Download custom profiles from www.hp.com.
5. Click the **OK** button to close the **Document Properties** dialog box. In the **Print** dialog box, click **Print** or **OK** to print the job.

Check paper and the printing environment

Complete the following steps to check the paper that you are using and the printer's physical environment.

Step one: Use paper that meets HP specifications

Some print-quality problems arise from using paper that does not meet HP specifications. Problems could include curled paper, light or faded printing, ink specks or smears, and misshapen characters. Follow these guidelines when selecting paper:

- Always use a paper type and weight that this printer supports.
- Use paper that is of good quality and free of cuts, nicks, tears, spots, loose particles, dust, wrinkles, voids, staples, and curled or bent edges.
- Use paper that has not been previously printed on.
- Use paper that does not contain metallic material, such as glitter.
- Use paper that is designed for HP PageWide printers. Do not use paper that is designed only for laser printers.
- Use paper that is not too rough. Using smoother paper generally results in better print quality.



NOTE: For this printer, HP highly recommends using papers with the ColorLok® logo, based on HP internal testing using a range of plain papers. For details, go to: www.hp.com/go/printpermanence.

Step two: Check the environment

The environment can directly affect print quality and is a common cause for print-quality or paper-feeding issues. Try the following solutions:

- Move the printer away from drafty locations, such as open windows or doors, or air-conditioning vents.
- Make sure the printer is not exposed to temperatures or humidity outside of printer specifications.
- Do not place the printer in a confined space, such as a cabinet.

- Place the printer on a sturdy, level surface.
- Remove anything that is blocking the vents on the printer. The printer requires good air flow on all sides, including the top.
- Protect the printer from airborne debris, dust, steam, grease, or other elements that can leave residue inside the printer.

Visually inspect the cartridge

Follow these steps to inspect each cartridge.

CAUTION: Do not touch the gold-colored metal contacts on the edge of the cartridge. Fingerprints on the metal contacts can cause print-quality problems.



1. Remove the cartridge from the printer, and verify that there is no debris in the cartridge path.
2. Check to see whether you are using a genuine HP cartridge. A genuine HP cartridge has the word “HP” on it, or has the HP logo on it. For more information on identifying HP cartridges go to www.hp.com/go/learnaboutesupplies.
3. Look at the gold-colored metal contacts on the cartridge.
 - If you see any scratches, or other damage on the metal contacts, replace the cartridge.
 - If the metal contacts do not appear to be damaged, push the cartridge gently back into its slot until it locks in place. Print a few pages to see if the problem has resolved.

If you determine that you need to replace a cartridge, look on the cartridge or print the Supplies Status Page to find the part number for the correct original HP cartridge.

Refilled or remanufactured cartridges

HP cannot recommend the use of non-HP supplies, either new or remanufactured. Because they are not HP products, HP cannot influence their design or control their quality. If you are using a refilled or remanufactured cartridge and are not satisfied with the print quality, replace the cartridge with an original HP cartridge.

NOTE: If you replace a non-HP cartridge with an original HP cartridge, the printhead will still contain non-HP ink. The print defect may remain until the printhead is depleted of that ink and is supplied with ink from the newly installed, original HP cartridge. Depleting the ink may require printing as many as several thousand pages of normal text.

Clean the printer

During the printing process, paper and dust particles can accumulate inside the printer and can cause print-quality issues such as smears, streaks, lines, or repeating marks. Begin by printing the Print Quality Report, and then continue to the appropriate cleaning procedure.

Print and interpret the Print Quality Report

The Print Quality Report is a page that is printed with bars of color from each cartridge. The report can help you identify print-quality issues.





1. Load plain letter-size or A4 paper.
2. From the Home screen on the printer control panel, select [Support Tools](#).
3. Open the following menus:
 - [Troubleshooting](#)
 - [Print Quality Pages](#)
 - [Print Quality Report](#)
4. Select [Print](#) to print the page.
5. Examine the bands of color on the report. Each bar has three distinct shades, but the color should vary minimally across the bars.
 - If one or more color bars show streaking, go to “[Clean the printhead.](#)”
 - If the color bars show little or no streaking, but the ink is smeared, go to “[Clean the rollers.](#)”

Clean the printhead

If the Print Quality Report shows streaking, follow these steps to clean the printhead.

1. From the Home screen on the printer control panel, select [Support Tools](#).
2. Open the following menus:
 - [Maintenance](#)
 - [Calibration/Cleaning](#)
 - [Printhead Cleaning](#)
3. Select [Start](#) to begin the cleaning process, and then follow the on-screen prompts.

 **NOTE:** There are sequential levels of cleaning. At the end of each level, the printer produces a Print Quality Report. If streaks appear in any of the color bars on the report, continue with the next level of cleaning. If the problem is solved, select [Cancel](#).

 **TIP:** Number each of the Print Quality Report pages in order to track print-quality improvement.

Clean the rollers

If the Print Quality Report shows smearing, follow these steps to clean the rollers.

Step one: Multifunction printers only—Clean the document feeder rollers

1. From the Home screen on the printer control panel, select [Support Tools](#).
2. Open the following menus:
 - [Maintenance](#)
 - [Calibration/Cleaning](#)
 - [Clean Document Feeder Rollers](#)
3. Select [Clean Now](#) to begin the cleaning process, and then follow the on-screen prompts.

Step two: Resolve Smear

1. From the Home screen on the printer control panel, select [Support Tools](#).
2. Open the following menus:
 - [Maintenance](#)
 - [Calibration/Cleaning](#)
 - [Resolve smear](#)
3. Select [Start](#) to begin the cleaning process.

This process will take up to three minutes as a page feeds slowly through the printer. Retain this page for further print-quality evaluation.

Try a different print driver

Try a different print driver when printing from a software program and the printed pages have unexpected lines in graphics, missing text, missing graphics, incorrect formatting, or substituted fonts.

Download any of the following drivers from the HP website: www.hp.com/support/pwcolor780MFP or www.hp.com/support/pwcolor785MFP.

HP PCL6 driver	This product-specific print driver is for Windows XP 32 bit, Vista 32 bit, and Server 2008 32 bit operating systems. Not all features or page sizes are supported.
HP PCL 6 driver	This product-specific print driver is for Windows 7, 8, 8.1, 10, Server 2008 64 bit, Server 2008 R2, Server 2012, and Server 2012 R2 operating systems.
HP PCL-6 driver	This product-specific print driver is for Windows 7, 8, 8.1, 10, Server 2008 64 bit, Server 2008 R2, Server 2012, and Server 2012 R2 operating systems.

HP UPD PS driver

- Recommended for printing with Adobe® software programs or with other highly graphics-intensive software programs
- Provides support for printing from postscript emulation needs, or for postscript flash font support

HP UPD PCL 6

- Recommended for printing in all Windows environments
 - Provides the overall best speed, print quality, and printer feature support for most users
 - Developed to align with Windows Graphic Device Interface (GDI) for best speed in Windows environments
 - Might not be fully compatible with third-party and custom software programs that are based on PCL 5
-

Improve copy image quality

If the printer is having copy quality problems, try the following solutions in the order presented to resolve the issue.

- [Check the scanner glass for dirt and smudges](#)
- [Calibrate the scanner](#)
- [Check the paper settings](#)
- [Check the image-adjustment settings](#)
- [Optimize copy quality for text or pictures](#)
- [Edge-to-edge copying](#)

Try these few simple steps first:

- Use the flatbed scanner rather than the document feeder.
- Use high-quality originals.
- When using the document feeder, load the original document into the feeder correctly, using the paper guides, to avoid unclear or skewed images.

If the problem still exists, try these additional solutions. If they do not fix the problem, see “Improve print quality” for further solutions.

Check the scanner glass for dirt and smudges

Over time, specks of debris might collect on the scanner glass and white plastic backing, which can affect performance. Use the following procedure to clean the scanner if the printed pages have streaks, unwanted lines, black dots, poor print quality, or unclear text.

1. Press the power button to turn the printer off, and then disconnect the power cable from the electrical outlet.

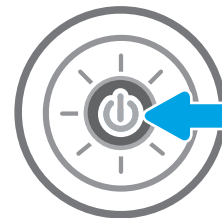

2. Open the scanner lid.

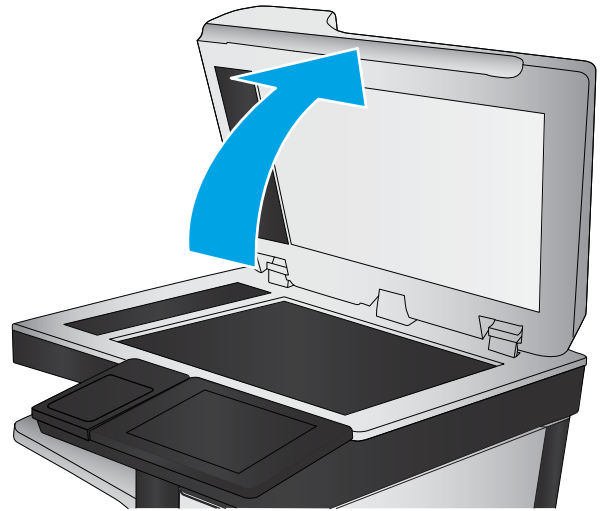

3. Clean the scanner glass and the document feeder strips with a soft cloth or sponge that has been moistened with nonabrasive glass cleaner.

CAUTION: Do not use abrasives, acetone, benzene, ammonia, ethyl alcohol, or carbon tetrachloride on any part of the printer; these can damage the printer. Do not place liquids directly on the glass or platen. They might seep and damage the printer.

NOTE: If you are having trouble with streaks on copies when you are using the document feeder, be sure to clean the small strip of glass on the left side of the scanner.

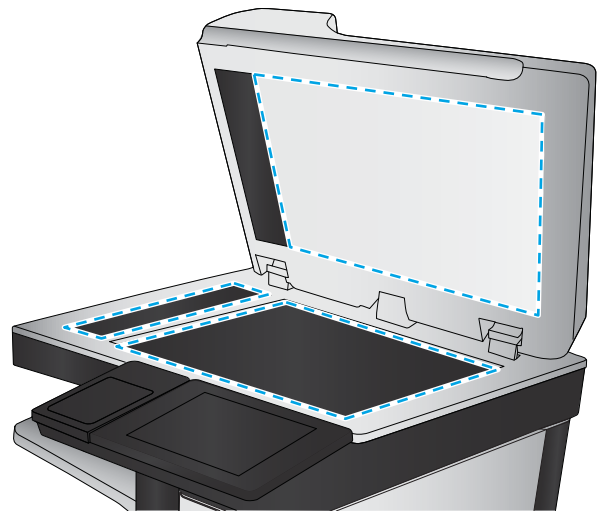

4. Dry the glass and white plastic parts with a chamois or a cellulose sponge to prevent spotting.
5. Connect the power cable to an outlet, and then press the power button to turn the printer on.

Calibrate the scanner

If the copied image is not positioned correctly on the page, follow these steps to calibrate the scanner.

 **NOTE:** When using the document feeder, make sure to adjust the guides in the input tray so they are against the original document.

1. From the Home screen on the printer control panel, swipe until the [Support Tools](#) menu displays. Touch the [Support Tools](#) icon to open the menu.
2. Open the following menus:

- [Maintenance](#)
 - [Calibration/Cleaning](#)
 - [Calibrate Scanner](#)
3. Touch the [Start](#) button to start the calibration process. Follow the on-screen prompts.
 4. Wait while the printer calibrates, and then try copying again.

Check the paper settings

Follow these steps if copied pages have smears, fuzzy or dark print, curled paper, or areas where pigment has dropped out.

Check the paper selection options

1. From the Home screen on the printer control panel, select [Copy](#).
2. Select [Options](#), and then scroll to and select [Paper Selection](#).
3. Select [Paper size](#), and then select one of the predefined options.
4. Select [Paper type](#), and then select one of the predefined options.
5. Select [Paper tray](#), and then select one of the predefined options.
6. Select [Done](#) to save the paper selection options.

Check the image-adjustment settings

Adjust these additional settings to improve copy quality:

- [Sharpness](#): Clarify or soften the image. For example, increasing the sharpness could make text appear crisper, but decreasing it could make photos appear smoother.
 - [Darkness](#): Increase or decrease the amount of white and black used in colors in scanned images.
 - [Contrast](#): Increase or decrease the difference between the lightest and the darkest color on the page.
 - [Background Cleanup](#): Remove faint colors from the background of scanned images. For example, if the original document is printed on colored paper, use this feature to lighten the background without affecting the darkness of the image.
 - [Automatic Tone](#): Available for Flow printers only. The printer automatically adjusts the [Darkness](#), [Contrast](#), and [Background Cleanup](#) settings to the most appropriate for the scanned document.
1. From the Home screen on the printer control panel, select [Copy](#).
 2. Select [Options](#), and then scroll to and select [Image Adjustment](#).
 3. Adjust the sliders to set the levels, and select [Done](#).
 4. Select [Copy](#) to start the copy job.



NOTE: These settings are temporary. After you have finished the job, the printer returns to the default settings.

Optimize copy quality for text or pictures

Optimize the copy job for the type of image being copied: text, graphics, or photos.

1. From the Home screen on the printer control panel, select [Copy](#).
2. Select [Options](#), and then select [Optimize Text/Picture](#).
3. Select one of the predefined options.
4. Select [Copy](#) to start the copy job.

 **NOTE:** These settings are temporary. After you have finished the job, the printer returns to the default settings.

Edge-to-edge copying

Use this feature to avoid shadows that can appear along the edges of copies when the original document is printed close to the edges.

1. From the Home screen on the printer control panel, select [Copy](#).
2. Select [Options](#), and then select [Edge-To-Edge](#).
3. Select the [Edge-To-Edge output](#) option if the original document is printed close to the paper edges.
4. Select [Copy](#) to start the copy job.

Improve scan image quality

- [Check the scanner glass for dirt and smudges](#)
- [Check the resolution settings](#)
- [Check the image-adjustment settings](#)
- [Optimize scan quality for text or pictures](#)
- [Check the output-quality settings](#)
- [Clean the pickup rollers and separation pad in the document feeder](#)

Try these few simple steps first:

- Use the flatbed scanner rather than the document feeder.
- Use high-quality originals.
- When using the document feeder, load the original document into the feeder correctly, using the paper guides, to avoid unclear or skewed images.

If the problem still exists, try these additional solutions. If they do not fix the problem, see “Improve print quality” for further solutions.

Check the scanner glass for dirt and smudges

Over time, specks of debris might collect on the scanner glass and white plastic backing, which can affect performance. Use the following procedure to clean the scanner if the printed pages have streaks, unwanted lines, black dots, poor print quality, or unclear text.

1. Press the power button to turn the printer off, and then disconnect the power cable from the electrical outlet.

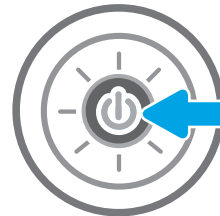

2. Open the scanner lid.

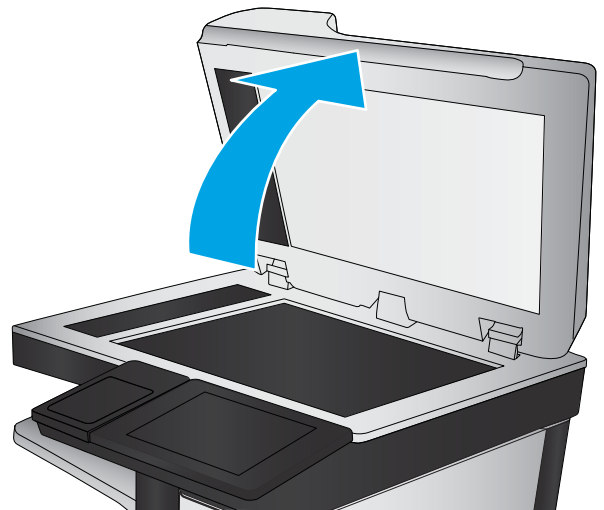

3. Clean the scanner glass and the document feeder strips with a soft cloth or sponge that has been moistened with nonabrasive glass cleaner.

CAUTION: Do not use abrasives, acetone, benzene, ammonia, ethyl alcohol, or carbon tetrachloride on any part of the printer; these can damage the printer. Do not place liquids directly on the glass or platen. They might seep and damage the printer.

NOTE: If you are having trouble with streaks on copies when you are using the document feeder, be sure to clean the small strip of glass on the left side of the scanner.

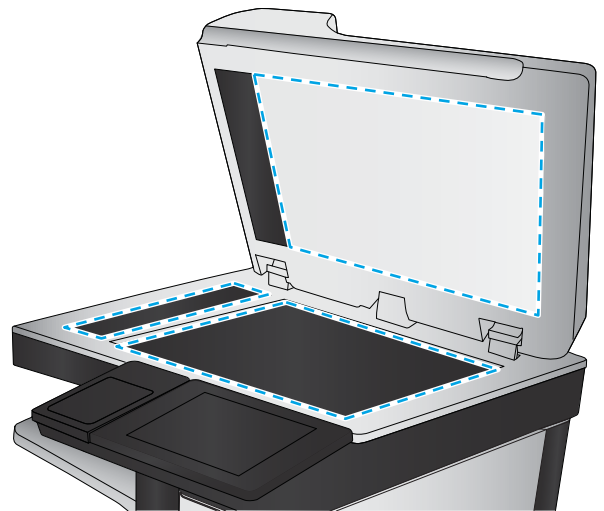

4. Dry the glass and white plastic parts with a chamois or a cellulose sponge to prevent spotting.
5. Connect the power cable to an outlet, and then press the power button to turn the printer on.

Check the resolution settings

 **NOTE:** Setting the resolution to a high value increases the file size and the scan time.

Follow these steps to adjust the resolution setting:

1. From the Home screen on the printer control panel, select [Scan](#).
2. Select one of the following Scan features:
 - [Scan to Email](#)
 - [Scan to Network Folder](#)

- [Scan to USB Drive](#)
 - [Scan to SharePoint®](#)
3. Select [Options](#), and then select [File Type and Resolution](#).
 4. Select one of the predefined [Resolution](#) options, and then select [Done](#).
 5. Select [Send](#) or [Save](#) to start the scan.

Check the image-adjustment settings

Adjust these additional settings to improve scan quality:

- [Sharpness](#): Clarify or soften the image. For example, increasing the sharpness could make text appear crisper, but decreasing it could make photos appear smoother.
 - [Darkness](#): Increase or decrease the amount of white and black used in colors in scanned images.
 - [Contrast](#): Increase or decrease the difference between the lightest and the darkest color on the page.
 - [Background Cleanup](#): Remove faint colors from the background of scanned images. For example, if the original document is printed on colored paper, use this feature to lighten the background without affecting the darkness of the image.
 - [Automatic Tone](#): Available for Flow printers only. The printer automatically adjusts the [Darkness](#), [Contrast](#), and [Background Cleanup](#) settings to the most appropriate for the scanned document.
1. From the Home screen on the printer control panel, select [Scan](#).
 2. Select one of the following Scan features:
 - [Scan to E-mail](#)
 - [Scan to Network Folder](#)
 - [Scan to USB Drive](#)
 - [Scan to Job Storage](#)
 - [Scan to SharePoint®](#)
 3. Select [Options](#), and then select [Image Adjustment](#).
 4. Adjust the sliders to set the levels, and then select [Done](#).
 5. Select [Send](#) or [Save](#) to start the scan.



NOTE: These settings are temporary. After you have finished the job, the printer returns to the default settings.

Optimize scan quality for text or pictures

Optimize the scan job for the type of image being scanned: text, graphics, or photos.

1. From the Home screen on the printer control panel, select [Scan](#).
2. Select one of the following Scan features:

- [Scan to E-mail](#)
 - [Scan to Network Folder](#)
 - [Scan to USB Drive](#)
 - [Scan to Job Storage](#)
 - [Scan to SharePoint®](#)
3. Select [Options](#), and then select [Optimize Text/Picture](#).
 4. Select one of the predefined options.
 5. Select [Send](#) or [Save](#) to start the scan.

 **NOTE:** These settings are temporary. After you have finished the job, the printer returns to the default settings.

Check the output-quality settings

This setting adjusts the level of compression when saving the file. For the highest quality, select the highest setting.

1. From the Home screen on the printer control panel, select [Scan](#).
2. Select one of the following Scan features:
 - [Scan to Email](#)
 - [Scan to Network Folder](#)
 - [Scan to USB Drive](#)
 - [Scan to SharePoint®](#)
3. Select [Options](#), and then select [File Type and Resolution](#).
4. Select one of the predefined [Quality and File Size](#) options, and then select [Done](#).
5. Select [Send](#) or [Save](#) to start the scan.

Clean the pickup rollers and separation pad in the document feeder

Follow these steps if the document feeder does not pick up pages correctly or produces skewed output.

1. Lift the latch to release the document-feeder cover.

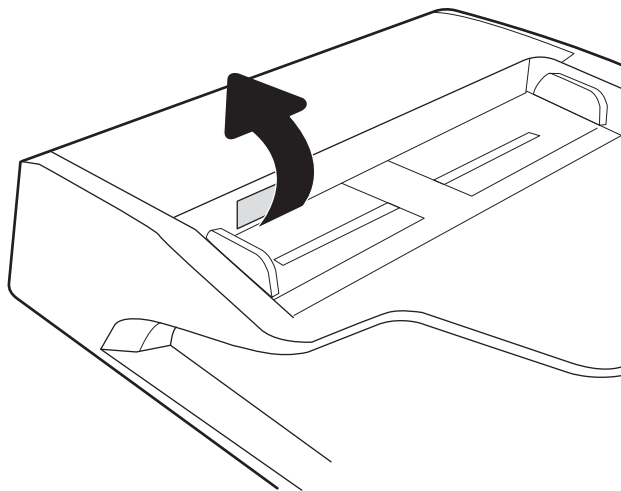

2. Open the document-feeder cover.

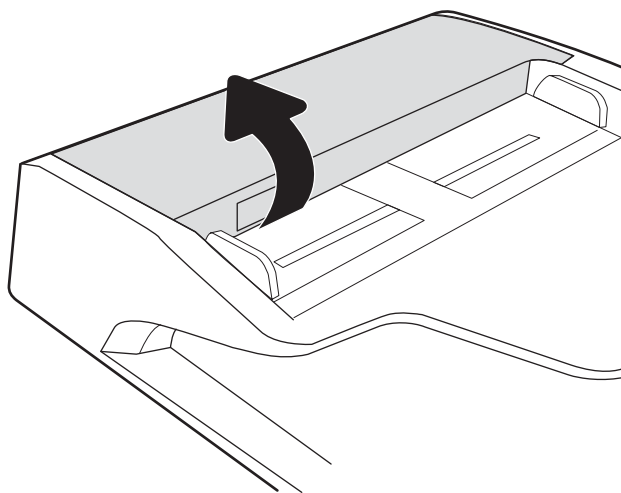

3. Remove any visible lint or dust from each of the feed rollers and the separation pad using compressed air or a clean lint-free cloth moistened with warm water.

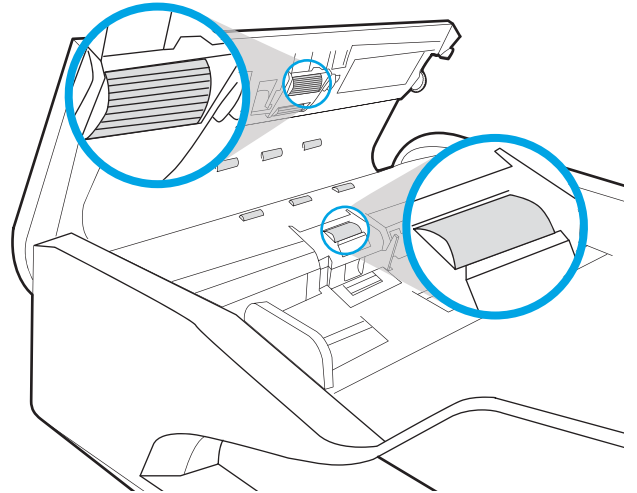

4. Close the document-feeder cover.

NOTE: Verify that the latch on the top of the document-feeder cover is completely closed.

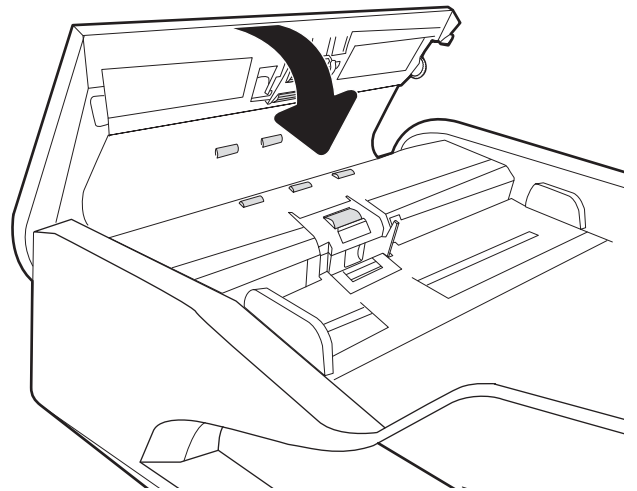

If the problem persists, check the document feeder separation pad and rollers for damage or wear, and replace them if necessary.

 **NOTE:** New rollers have a rough surface. As rollers wear, they become smooth.

Improve fax image quality

If the printer is having fax quality problems, try the following solutions in the order presented to resolve the issue.

- [Check the scanner glass for dirt and smudges](#)
- [Check the send-fax resolution settings](#)
- [Check the image-adjustment settings](#)
- [Optimize fax quality for text or pictures](#)
- [Check the error-correction settings](#)
- [Check the fit-to-page setting](#)
- [Clean the pickup rollers and separation pad in the document feeder](#)
- [Send to a different fax machine](#)
- [Check the sender's fax machine](#)

Try these few simple steps first:

- Use the flatbed scanner rather than the document feeder.
- Use high-quality originals.
- When using the document feeder, load the original document into the feeder correctly, using the paper guides, to avoid unclear or skewed images.

If the problem still exists, try these additional solutions. If they do not fix the problem, see “Improve print quality” for further solutions.

Check the scanner glass for dirt and smudges

Over time, specks of debris might collect on the scanner glass and white plastic backing, which can affect performance. Use the following procedure to clean the scanner if the printed pages have streaks, unwanted lines, black dots, poor print quality, or unclear text.

1. Press the power button to turn the printer off, and then disconnect the power cable from the electrical outlet.

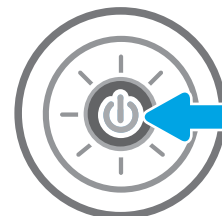

2. Open the scanner lid.

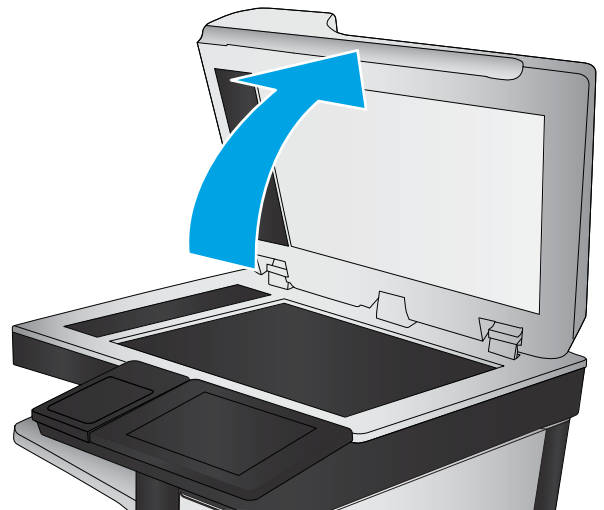

3. Clean the scanner glass and the document feeder strips with a soft cloth or sponge that has been moistened with nonabrasive glass cleaner.

CAUTION: Do not use abrasives, acetone, benzene, ammonia, ethyl alcohol, or carbon tetrachloride on any part of the printer; these can damage the printer. Do not place liquids directly on the glass or platen. They might seep and damage the printer.

NOTE: If you are having trouble with streaks on copies when you are using the document feeder, be sure to clean the small strip of glass on the left side of the scanner.

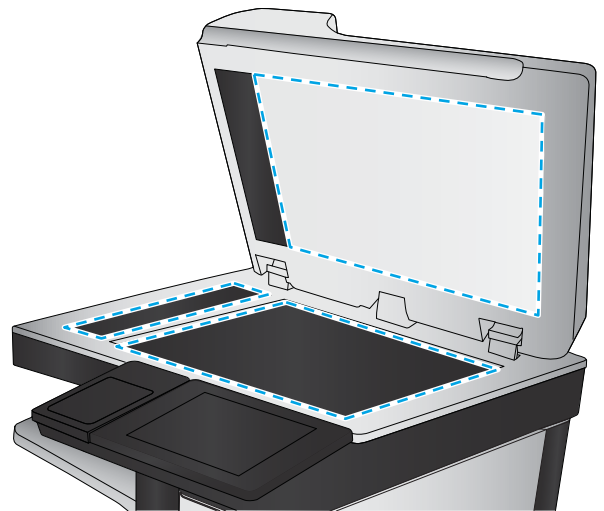

4. Dry the glass and white plastic parts with a chamois or a cellulose sponge to prevent spotting.
5. Connect the power cable to an outlet, and then press the power button to turn the printer on.

Check the send-fax resolution settings

Follow these steps to adjust the resolution of outgoing faxes.

 **NOTE:** Increasing the resolution increases the fax size and send time.

1. From the Home screen on the printer control panel, select **Fax**.
2. Select **Options**.
3. In the Options pane, scroll to and select **Resolution**.
4. Select one of the predefined options, and then select **Send** to send the fax.

Check the image-adjustment settings

Adjust these additional settings to improve send-fax quality:

- **Sharpness:** Clarify or soften the image. For example, increasing the sharpness could make text appear crisper, but decreasing it could make photos appear smoother.
 - **Darkness:** Increase or decrease the amount of white and black used in colors in scanned images.
 - **Contrast:** Increase or decrease the difference between the lightest and the darkest color on the page.
 - **Background Cleanup:** Remove faint colors from the background of scanned images. For example, if the original document is printed on colored paper, use this feature to lighten the background without affecting the darkness of the image.
 - **Automatic Tone:** Available for Flow printers only. The printer automatically adjusts the **Darkness**, **Contrast**, and **Background Cleanup** settings to the most appropriate for the scanned document.
1. From the Home screen on the printer control panel, select **Fax**.
 2. Select **Options**.
 3. In the Options pane, scroll to and select **Image Adjustment**.
 4. Adjust the sliders to set the levels, and then select **Done**.
 5. Select **Send** to send the fax.



NOTE: These settings are temporary. After you have finished the job, the printer returns to the default settings.

Optimize fax quality for text or pictures

Optimize the fax job for the type of image being scanned: text, graphics, or photos.

1. From the Home screen on the printer control panel, select **Fax**.
2. Select **Options**.
3. In the Options pane, scroll to and select **Optimize Text/Picture**.
4. Select one of the predefined options.
5. Select **Send** to send the fax.



NOTE: These settings are temporary. After you have finished the job, the printer returns to the default settings.

Check the error-correction settings

The **Error Correction Mode** setting might be disabled, which can reduce image quality. Follow these steps to re-enable the setting.

1. From the Home screen on the printer control panel, swipe until the **Settings** menu displays. Touch the **Settings** icon to open the menu.
2. Open the following menus:

- [Fax](#)
 - [Fax Send Settings](#)
 - [General Fax Send Settings](#)
3. Select the [Error Correction Mode](#) option. Touch the [Done](#) button.

Check the fit-to-page setting

If the [Fit to Page](#) setting is enabled, and the incoming fax is larger than the default page size, the printer attempts to scale the image to fit the page. If this setting is disabled, larger images split across multiple pages.

1. From the Home screen on the printer control panel, select [Settings](#).
2. Open the following menus:
 - [Fax](#)
 - [Fax Receive Settings](#)
 - [Default Job Options](#)
 - [Fit to Page](#)
3. Select the [On](#) option to enable the setting, or select the [Off](#) option to disable it.

Clean the pickup rollers and separation pad in the document feeder

Follow these steps if the document feeder does not pick up pages correctly or produces skewed output.

1. Lift the latch to release the document-feeder cover.

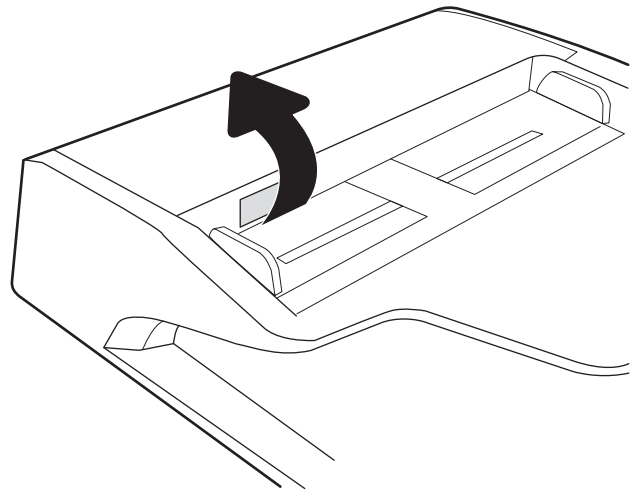

2. Open the document-feeder cover.

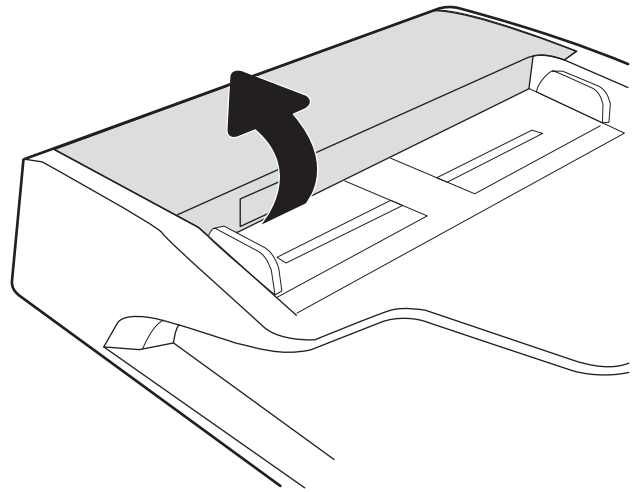

3. Remove any visible lint or dust from each of the feed rollers and the separation pad using compressed air or a clean lint-free cloth moistened with warm water.

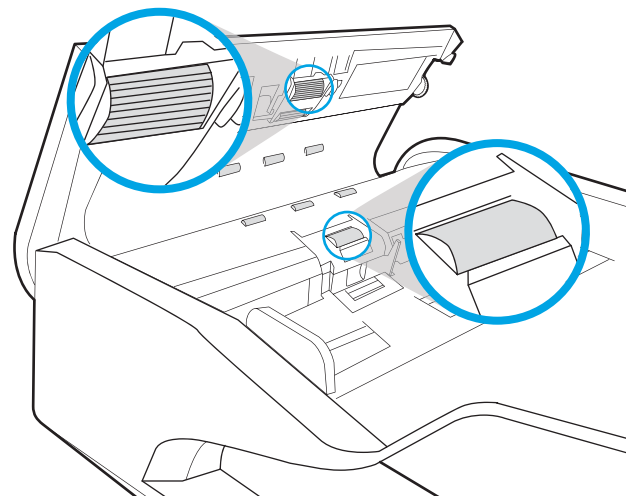

4. Close the document-feeder cover.

NOTE: Verify that the latch on the top of the document-feeder cover is completely closed.

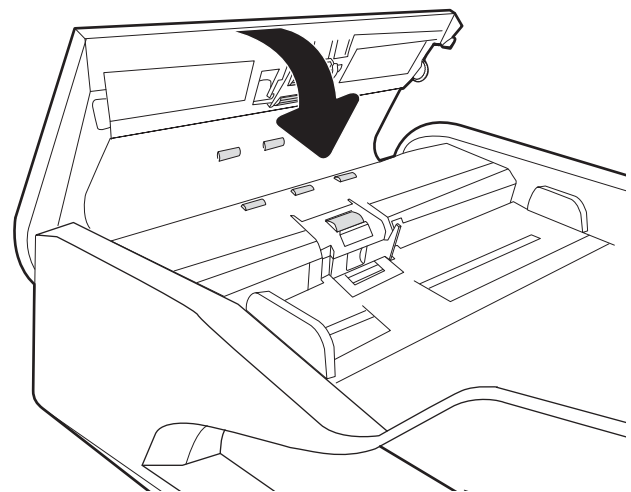

If the problem persists, check the document feeder separation pad and rollers for damage or wear, and replace them if necessary.



NOTE: New rollers have a rough surface. As rollers wear, they become smooth.

Send to a different fax machine

Try sending the fax to a different fax machine. If the fax quality is better, the problem is related to the initial recipient's fax machine settings or supplies status.

Check the sender's fax machine

Ask the sender to try sending from a different fax machine. If the fax quality is better, the problem is with the sender's fax machine. If a different fax machine is unavailable, ask the sender to consider making the following changes:

- Make sure the original document is on white (not colored) paper.
- Increase the fax resolution, quality level, or contrast settings.
- If possible, send the fax from a computer software program.

Solve wired network problems

Introduction

Certain types of problems can indicate there is a network communication problem. These problems include the following issues:

- The periodic loss of ability to communicate with the printer
- The printer cannot be found during driver installation
- A periodic failure to print



NOTE: If you have been experiencing intermittent loss of network connectivity, first update the printer firmware. For instructions on how to update the printer firmware, go to <http://support.hp.com>, search for your printer, and then search on “update the firmware.”

Check the following items to verify that the printer is communicating with the network. Before beginning, print a configuration page from the printer control panel and locate the printer IP address that is listed on this page.

- [Poor physical connection](#)
- [The computer is unable to communicate with the printer](#)
- [The printer is using incorrect link and duplex settings for the network](#)
- [New software programs might be causing compatibility problems](#)
- [The computer or workstation might be set up incorrectly](#)
- [The printer is disabled, or other network settings are incorrect](#)



NOTE: HP does not support peer-to-peer networking, as the feature is a function of Microsoft operating systems and not of the HP print drivers. For more information, go to Microsoft at www.microsoft.com.

Poor physical connection

1. Verify that the printer is attached to the correct network port using a cable of the correct length.
2. Verify that cable connections are secure.
3. Look at the network port connection on the back of the printer, and verify that the amber activity light flashes indicating network traffic, and the green link-status light is continuously lit indicating a network link.
4. If the problem continues, try a different cable or port on the hub.

The computer is unable to communicate with the printer

1. Test network communication by pinging the network.
 - a. Open a command-line prompt on your computer.

- For Windows, click **Start**, click **Run**, type `cmd`, and then press [Enter](#).
 - For OS X, go to **Applications**, then **Utilities**, and open **Terminal**.
- b. Type `ping` followed by the IP address for your printer.
 - c. If the window displays round-trip times, the network is working.
2. If the ping command failed, verify that the network hubs are on, and then verify that the network settings, the printer, and the computer are all configured for the same network (also known as subnet).
 3. Open the printer properties and click the **Ports** tab. Verify that the current IP address for the printer is selected. The printer IP address is listed on the printer configuration page.
 4. If you installed the printer using the HP standard TCP/IP port, select the box labeled **Always print to this printer, even if its IP address changes**.
 5. If you installed the printer using a Microsoft standard TCP/IP port, use the printer's hostname instead of the IP address.
 6. If the IP address is correct, delete the printer and then add it again.

The printer is using incorrect link and duplex settings for the network

HP recommends leaving these settings in automatic mode (the default setting). If you change these settings, you must also change them for your network.

New software programs might be causing compatibility problems

Verify that any new software programs are correctly installed and that they use the correct print driver.

The computer or workstation might be set up incorrectly

1. Check the network drivers, print drivers, and the network redirection settings.
2. Verify that the operating system is configured correctly.

The printer is disabled, or other network settings are incorrect

1. Review the printer's configuration/networking pages to check the status of the network settings and protocols.
2. Reconfigure the network settings if necessary.

Solve wireless network problems

- [Introduction](#)
- [Wireless connectivity checklist](#)
- [The printer does not print after the wireless configuration completes](#)
- [The printer does not print, and the computer has a third-party firewall installed](#)
- [The wireless connection does not work after moving the wireless router or printer](#)
- [Cannot connect more computers to the wireless printer](#)
- [The wireless printer loses communication when connected to a VPN](#)
- [The network does not appear in the wireless networks list](#)
- [The wireless network is not functioning](#)
- [Reduce interference on a wireless network](#)

Introduction

Use the troubleshooting information to help resolve issues.

 **NOTE:** To determine whether HP NFC and Wi-Fi Direct printing are enabled on your printer, print a configuration page from the printer control panel.

 **NOTE:** If you have been experiencing intermittent loss of network connectivity, first update the printer firmware. For instructions on how to update the printer firmware, go to <http://support.hp.com>, search for your printer, and then search on “update the firmware.”

Wireless connectivity checklist

- For printers that do not support simultaneous wired and wireless connections, verify that the network cable is not connected.
- Verify that the printer and the wireless router are turned on and have power. Also make sure that the wireless radio in the printer is turned on. (The wireless network indicator is solid when the printer is connected to a wireless network, and blinking when it is searching for a wireless network.)
- Verify that the service set identifier (SSID) is correct:
 - For a wireless connection to your network, confirm that your mobile device is connecting to the correct router/access point.
 - For a Wi-Fi Direct connection, print a configuration page to determine the printer’s SSID.

If you are not sure that the SSID is correct, run the wireless setup again.

- With secured networks, verify that the security information is correct. If the security information is incorrect, run the wireless setup again.
- If the wireless network is working correctly, try accessing other computers on the wireless network. If the network has Internet access, try connecting to the Internet over a wireless connection.
- Verify that the encryption method (AES or TKIP) is the same for the printer as it is for the wireless access point (on networks using WPA security).

- Verify that the printer is within the range of the wireless network. For most networks, the printer must be within 30 m (100 ft) of the wireless access point (wireless router).
- Verify that obstacles do not block the wireless signal. Remove any large metal objects between the access point and the printer. Make sure poles, walls, or support columns containing metal or concrete do not separate the printer and wireless access point.
- Verify that the printer is located away from electronic devices that might interfere with the wireless signal. Many devices can interfere with the wireless signal including motors, cordless phones, security system cameras, other wireless networks, and some Bluetooth devices.
- Verify that the print driver is installed on the computer.
- Verify that you have selected the correct printer port.
- Verify that the computer and printer connect to the same wireless network.
- If your environment has multiple wireless signals and you need the printer to support dual band networks on both 2.4 GHz and 5 GHz, install the HP Jetdirect Z900nw print server accessory.
- For OS X, verify that the wireless router supports Bonjour.

The printer does not print after the wireless configuration completes

1. Make sure that the printer is turned on and in the ready state.
2. Turn off any third-party firewalls on your computer.
3. Make sure that the wireless network is working correctly.
4. Make sure that your computer is working correctly. If necessary, restart the computer.
5. Verify that you can open the printer HP Embedded Web Server from a computer on the network.

The printer does not print, and the computer has a third-party firewall installed

1. Update the firewall with the most recent update available from the manufacturer.
2. If programs request firewall access when you install the printer or try to print, make sure that you allow the programs to run.
3. Temporarily turn off the firewall, and then install the wireless printer on the computer. Enable the firewall when you have completed the wireless installation.

The wireless connection does not work after moving the wireless router or printer

1. Make sure that the router or printer connects to the same network that your computer connects to.
2. Print a configuration page.
3. Compare the service set identifier (SSID) on the configuration page to the SSID in the printer configuration for the computer.
4. If the numbers are not the same, the devices are not connecting to the same network. Reconfigure the wireless setup for the printer.

Cannot connect more computers to the wireless printer

1. Make sure that the other computers are within the wireless range and that no obstacles block the signal. For most networks, the wireless range is within 30 m (100 ft) of the wireless access point.
2. Make sure that the printer is turned on and in the ready state.
3. Make sure there are not more than 5 concurrent Wireless Print Direct users.
4. Turn off any third-party firewalls on your computer.
5. Make sure that the wireless network is working correctly.
6. Make sure that your computer is working correctly. If necessary, restart the computer.

The wireless printer loses communication when connected to a VPN

- Typically, you cannot connect to a VPN and other networks at the same time.

The network does not appear in the wireless networks list

- Make sure the wireless router is turned on and has power.
- The network might be hidden. However, you can still connect to a hidden network. Make sure the router/access point is advertising the SSID by checking for its SSID in the available networks seen by your mobile device.

The wireless network is not functioning

1. For printers that do not support simultaneous wired and wireless connections, make sure that the network cable is disconnected.
2. To verify if the network has lost communication, try connecting other devices to the network.
3. Test network communication by pinging the network.
 - a. Open a command-line prompt on your computer.
 - For Windows, click **Start**, click **Run**, type `cmd`, and then press **Enter**.
 - For OS X, go to **Applications**, then **Utilities**, and open **Terminal**.
 - b. Type `ping` followed by the router IP address.
 - c. If the window displays round-trip times, the network is working.
4. Make sure that the router or printer connects to the same network that the computer connects to.
 - a. Print a configuration page.
 - b. Compare the service set identifier (SSID) on the configuration report to the SSID in the printer configuration for the computer.
 - c. If the numbers are not the same, the devices are not connecting to the same network. Reconfigure the wireless setup for the printer.

Reduce interference on a wireless network

The following tips can reduce interference in a wireless network:

- Keep the wireless devices away from large metal objects, such as filing cabinets, and other electromagnetic devices, such as microwaves and cordless telephones. These objects can disrupt radio signals.
- Keep the wireless devices away from large masonry structures and other building structures. These objects can absorb radio waves and lower signal strength.
- Position the wireless router in a central location in line of sight with the wireless printers on the network.

Solve fax problems

- [Checklist for solving fax problems](#)
- [General fax problems](#)

Checklist for solving fax problems

Use the following checklist to help identify the cause of any fax-related problems you encounter:

- **Are you using the fax cable supplied with the fax accessory?** This fax accessory has been tested with the supplied fax cable to meet RJ11 and functional specifications. Do not substitute another fax cable; the analog-fax accessory requires an analog-fax cable. It also requires an analog phone connection.
- **Is the fax/phone line connector seated in the outlet on the fax accessory?** Make sure that the phone jack is correctly seated in the outlet. Insert the connector into the outlet until it "clicks."



NOTE: Verify that the phone jack is connected to the fax port rather than to the network port. The ports are similar.

- **Is the phone wall jack working properly?** Verify that a dial tone exists by attaching a phone to the wall jack. Can you hear a dial tone, and can you make or receive a phone call?

What type of phone line are you using?

- **Dedicated line:** A standard analog fax/phone line assigned to receive or send faxes.



NOTE: The phone line should be for printer fax use only and not shared with other types of telephone devices. Examples include alarm systems that use the phone line for notifications to a monitoring company.

- **PBX system:** A business-environment phone system. Standard home phones and the fax accessory use an analog phone signal. Some PBX systems are digital and might not be compatible with the fax accessory. You might need an interfacing Analog Telephone Adapter (ATA) to connect the fax machine to digital PBX systems.
- **Roll-over lines:** A phone system feature where a new call "rolls over" to the next available line when the first incoming line is busy. Try attaching the printer to the first incoming phone line. The fax accessory answers the phone after it rings the number of times set in the rings-to-answer setting.

Are you using a surge-protection device?

A surge-protection device can be used between the wall jack and the fax accessory to protect the fax accessory against electrical power passed through the phone lines. These devices can cause some fax communication problems by degrading the quality of the phone signal. If you are having problems sending or receiving faxes and are using one of these devices, connect the printer directly to the phone jack on the wall to determine whether the problem is with the surge-protection device.

Are you using a phone company voice-messaging service or an answering machine?

If the rings-to-answer setting for the messaging service is lower than the rings-to-answer setting for the fax accessory, the messaging service answers the call, and the fax accessory cannot receive faxes. If the rings-to-answer setting for the fax accessory is lower than that of the messaging service, the fax accessory answers all calls.

Does your phone line have a call-waiting feature?

If the fax telephone line has an activated call-waiting feature, a call-waiting notice can interrupt a fax call in progress, which causes a communication error. Ensure that a call-waiting feature is not active on the fax telephone line.

Check fax accessory status

If the analog-fax accessory does not appear to be functioning, print a [Configuration Page](#) report to check the status.

1. From the Home screen, scroll to and select [Reports](#).
2. Open the following menus:
 - [Configuration/Status Pages](#)
 - [Configuration Page](#)
3. Touch the [Print](#) button to print the report, or touch the [View](#) button to view the report on the screen. The report consists of several pages.

 **NOTE:** The printer IP address or host name is listed on the Jetdirect Page.

On the Fax Accessory Page of the Configuration Page, under the Hardware Information heading, check the Modem Status. The following table identifies the status conditions and possible solutions.

 **NOTE:** If the Fax Accessory Page does not print, there might be a problem with the analog fax accessory. If you are using LAN fax or Internet fax, those configurations could be disabling the feature.

Operational / Enabled ¹	The analog-fax accessory is installed and ready.
Operational / Disabled ¹	The fax accessory is installed, but you have not configured the required fax settings yet. The fax accessory is installed and operational; however, the HP Digital Sending utility has either disabled the printer fax feature or has enabled LAN fax. When LAN fax is enabled, the analog-fax feature is disabled. Only one fax feature, either LAN fax or analog fax, can be enabled at a time. NOTE: If LAN fax is enabled, the Scan to Fax feature is unavailable on the printer control panel.
Non-Operational / Enabled/Disabled ¹	The printer has detected a firmware failure. Upgrade the firmware.
Damaged / Enabled/Disabled ¹	The fax accessory has failed. Reseat the fax accessory card and check for bent pins. If the status is still DAMAGED, replace the analog-fax accessory card.

¹ ENABLED indicates that the analog-fax accessory is enabled and turned on; DISABLED indicates that LAN fax is enabled (analog fax is turned off).

General fax problems

The following are some common fax problems.

The fax failed to send

JBIG is enabled, and the receiving fax machine does not have JBIG capability.

Turn off the JBIG setting.

An Out of Memory status message displays on the printer control panel

The printer storage disk is full.

Delete some stored jobs from the disk. From the Home screen on the printer control panel, touch the [Retrieve from Device Memory](#) button. Open the list of stored jobs or stored faxes. Select a job to delete, and then touch the [Delete](#) button.

Print quality of a photo is poor or prints as a gray box

You are using the wrong page-content setting or the wrong resolution setting.

Try setting the [Optimize Text/Picture](#) option to [Photograph](#) setting.

You touched the Stop button to cancel a fax, but the fax was still sent

If the job is too far along in the sending process, you cannot cancel the job.

This is normal operation.

No fax address book button displays

None of the contacts in the selected contacts list have fax information associated with them.

Not able to locate the Fax settings in HP Web Jetadmin

Fax settings in HP Web Jetadmin are located under the device's status page drop-down menu.

Select **Digital Sending and Fax** from the drop-down menu.

The header is appended to the top of the page when the overlay option is enabled

For all forwarded faxes, the printer appends the overlay header to the top of a page.

This is normal operation.

A mix of names and numbers is in the recipients box

Names and numbers can both display, depending on where they are from. The fax address book lists names, and all other databases list numbers.

This is normal operation.

A one-page fax prints as two pages

The fax header is being appended to the top of the fax, pushing text to a second page.

To print a one page fax on one page, set the overlay header to overlay mode, or adjust the fit-to-page setting.

A document stops in the document feeder in the middle of faxing

A jam is in the document feeder.

Clear the jam, and send the fax again.

The volume for sounds coming from the fax accessory is too high or too low

The volume setting needs to be adjusted.

Adjust the volume in the [Fax Send Settings](#) menu and the [Fax Receive Settings](#) menu.

Index

Symbols/Numerics

- 1x550-sheet trays
 - loading labels 39
- 550-sheet trays
 - jams 194, 201

A

- accessories
 - ordering 46
- acoustic specifications 14
- AirPrint 74
- alternative letterhead mode 24, 31, 35
- Android devices
 - printing from 74

B

- bin, output
 - locating 3
- Bonjour
 - identifying 142
- browser requirements
 - HP embedded Web Server 142

C

- calibrate
 - scanner 221
- cartridge
 - low threshold settings 175
 - using when low 175
- cartridges
 - components 50
 - order information 50
 - part numbers 50
 - replacing 50
 - replacing staple 58
- checklist
 - wireless connectivity 238

- cleaning 217
 - glass 220, 224, 230
- color options
 - changing, Windows 214
- color theme
 - changing, Windows 214
- control panel
 - help 173
 - locating 3
 - locating features 5
- copy
 - optimize for text or pictures 223
- copy settings
 - HP Embedded Web Server 145
- copying
 - both sides 82
 - multiple copies 80
 - resolution 8
 - single copies 80
- customer support
 - online 172

D

- default gateway, setting 162
- deleting
 - stored jobs 70
- digital send settings
 - HP Embedded Web Server 146
- digital sending
 - folders 122
 - printer memory 128
 - sending documents 119
 - USB 124
- dimensions, printer 12
- document feeder
 - capacity 8
 - cleaning 227, 233
 - jams 187

- locating 3
 - paper-feeding problems 183
- document feeder rollers
 - cleaning 227, 233
- double-sided printing
 - Mac 66
 - Windows 63
- drivers, supported 10
- duplex printing
 - Mac 66
- duplex printing (double-sided)
 - settings (Windows) 62
 - Windows 63
- duplexer
 - clearing jams 200
- duplexing
 - manually (Mac) 66
 - manually (Windows) 63

E

- easy-access USB printing 76
- edge-to-edge copying 223
- electrical specifications 14
- Embedded Web Server
 - changing network settings 161
 - changing printer name 161
 - opening 161
- Embedded Web Server (EWS)
 - assigning passwords 164
 - features 142
 - network connection 142
- energy use, optimizing 166
- envelopes
 - orientation 19
- envelopes, loading 37
- Ethernet (RJ-45)
 - locating 4
- Explorer, versions supported
 - HP Embedded Web Server 142

- F**
- fax
 - feeding problems 244
 - optimize for text or pictures 232
 - required settings 134
 - settings 135
 - setup 134
- fax port
 - locating 4
- fax settings
 - HP Embedded Web Server 147
 - required 134
- feeding problems 244
- folders
 - sending to 122
- formatter
 - locating 4
- G**
- gateway, setting default 162
- general configuration
 - HP Embedded Web Server 144
- glass, cleaning 220, 224, 230
- H**
- hard disks
 - encrypted 165
- hardware integration pocket (HIP)
 - locating 3
- HCI. *See* high-capacity input tray
- Help button
 - locating 5
- help, control panel 173
- Hi-Speed USB 2.0 printing port
 - locating 4
- high-capacity input tray
 - loading 32
- HIP (hardware integration pocket)
 - locating 3
- Home button
 - locating 5
- HP Customer Care 172
- HP Embedded Web Server
 - changing network settings 161
 - changing printer name 161
 - copy settings 145
 - digital send settings 146
 - fax settings 147
 - general configuration 144
 - HP Web Services 148
 - information pages 143
 - network settings 148
 - opening 161
 - other links list 150
 - print settings 145
 - scan settings 146
 - security settings 148
 - troubleshooting tools 147
- HP Embedded Web Server (EWS)
 - features 142
 - network connection 142
- HP ePrint 73
- HP ePrint software 74
- HP JetAdvantage business solutions 131
- HP Web Jetadmin 168
- HP Web Services
 - enabling 148
- I**
- image quality
 - check cartridge status 212
- information pages
 - HP Embedded Web Server 143
- inner finisher
 - clear jams 208
 - clear staple jams 210
- inner finisher accessory
 - configure the operation mode 42
- interface ports
 - locating 4
- Internet Explorer, versions supported
 - HP Embedded Web Server 142
- IP Security 165
- IPsec 165
- IPv4 address 162
- IPv6 address 162
- J**
- jams
 - 550-sheet trays 194, 201
 - auto-navigation 186
 - causes of 186
 - document feeder 187
 - duplexer 200
 - high-capacity input tray 204
 - inner finisher 208
 - output bin 198
 - staples in the inner finisher 210
 - Tray 1 189
 - Tray 2 192
- jams, paper
 - locations 185
- Jetadmin, HP Web 168
- JetAdvantage 131
- jobs, stored
 - creating (Windows) 68
 - deleting 70
 - Mac settings 69
 - printing 70
- K**
- keyboard
 - locating 3
- L**
- label
 - orientation 39
- labels
 - printing (Windows) 64
 - printing on 39
- labels, loading 39
- LAN port
 - locating 4
- left door
 - locating 3
- loading
 - paper in the 4,000-sheet high-capacity input tray 32
 - paper in Tray 1 18
 - paper in Tray 2 25
- local area network (LAN)
 - locating 4
- lock
 - formatter 165
- M**
- Mac driver settings
 - Job Storage 69
- maintenance kits
 - part numbers 47
- managing network 161
- manual duplex
 - Mac 66
 - Windows 63
- margins, small
 - copying 223
- memory
 - included 8

- mobile printing
 - Android devices 74
- mobile printing solutions 8
- mobile printing, software supported 12
- multiple pages per sheet
 - printing (Mac) 67
 - printing (Windows) 63

N

- Near Field Communication printing 72
- Netscape Navigator, versions supported
 - HP embedded Web Server 142
- network
 - printer name, changing 161
 - settings, changing 161
 - settings, viewing 161
- network duplex settings, changing 163
- Network Folder, scan to 122
- network link speed settings, changing 163
- network settings
 - HP Embedded Web Server 148
- networks
 - default gateway 162
 - HP Web Jetadmin 168
 - IPv4 address 162
 - IPv6 address 162
 - subnet mask 162
 - supported 8
- NFC connect and print 72
- number of copies, changing 80

O

- on/off button
 - locating 3
- online help, control panel 173
- online support 172
- operating systems (OS)
 - supported 8
- operating systems, supported 10
- optimize copy images 223
- optimize fax images 232
- optimize scanned images 226
- ordering
 - supplies and accessories 46

- OS (operating system)
 - supported 8
- other links list
 - HP Embedded Web Server 150
- output bin
 - clear jams 198
 - locating 3

P

- pages per minute 8
- pages per sheet
 - selecting (Mac) 67
 - selecting (Windows) 63
- paper
 - jams 186
 - loading the 4,000-sheet high-capacity input tray 32
 - loading Tray 1 18
 - loading Tray 2 25
 - selecting 215
 - Tray 1 orientation 19
- paper jams
 - 550-sheet trays 194, 201
 - document feeder 187
 - high-capacity input tray 204
 - inner finisher 208
 - locations 185
 - output bin 198
 - Tray 1 189
- paper pickup problems
 - solving 177, 179
- paper type
 - selecting (Windows) 64
- paper types
 - selecting (Mac) 67
- paper, ordering 46
- part numbers
 - replacement parts 47
 - staple cartridges 47
- ports
 - locating 4
- power
 - consumption 14
- power connection
 - locating 4
- power switch
 - locating 3
- power usage
 - 1 watt or less 166
- print drivers, supported 10

- print media
 - loading in Tray 1 18
- print on both sides
 - Mac 66
 - manually, Windows 63
 - Windows 63
- print settings
 - HP Embedded Web Server 145
- printer memory
 - sending to 128
- printer memory, scan to 128
- printing
 - from USB storage accessories 76
 - stored jobs 70
- printing on both sides
 - settings (Windows) 62
- priority input tray
 - loading envelopes 37
- private printing 68

R

- replacement parts
 - part numbers 47
- replacing
 - cartridges 50
 - staple cartridges 58
- required settings
 - fax 134
- resolution
 - copy and scan 8
- restore factory settings 174
- right door
 - locating 3
- rollers
 - cleaning, document feeder 227, 233

S

- Save to printer memory 128
- scan settings
 - HP Embedded Web Server 146
- Scan to Network Folder 122
 - initial setup 99
- Scan to USB Drive 124
 - enabling 110
- scanner
 - calibrate 221
 - glass cleaning 220, 224, 230

- scanning
 - optimize for text or pictures 226
 - resolution 8
 - scanning to email
 - sending documents 119
 - scanning to folder 122
 - scanning to printer folder 128
 - scanning to printer memory 128
 - scanning to USB 124
 - security settings
 - HP Embedded Web Server 148
 - security
 - encrypted hard disk 165
 - security lock slot
 - locating 4
 - sending to email
 - sending documents 119
 - service fluid container
 - replace 54
 - settings
 - fax 135
 - restore factory 174
 - Sign In button
 - locating 5
 - Sign Out button
 - locating 5
 - sleep mode 166
 - small margins 223
 - special paper
 - printing (Windows) 64
 - specifications
 - electrical and acoustic 14
 - speed, optimizing 166
 - staple cartridges
 - replacing 58
 - staple jams
 - inner finisher 210
 - stapler
 - setting default staple location 41
 - stapler door
 - locating 4
 - stapling
 - configure the operation mode 42
 - setting default location 41
 - Start Copy button
 - locating 5
 - status, fax accessory page 243
 - storage, job
 - Mac settings 69
 - store print jobs 68
 - stored jobs
 - creating (Mac) 69
 - creating (Windows) 68
 - deleting 70
 - printing 70
 - storing jobs
 - with Windows 68
 - subnet mask 162
 - supplies
 - low threshold settings 175
 - ordering 46
 - part numbers 47
 - replacing cartridges 50
 - replacing staple cartridges 58
 - using when low 175
 - support
 - online 172
 - system requirements
 - HP Embedded Web Server 142
 - minimum 12
- T**
- TCP/IP
 - manually configuring IPv4
 - parameters 162
 - manually configuring IPv6
 - parameters 162
 - technical support
 - online 172
 - touchscreen
 - locating features 5
 - transparencies
 - printing (Windows) 64
 - Tray 1
 - jams 189
 - loading envelopes 37
 - locating 4
 - paper orientation 19
 - Tray 1 extension
 - locating 4
 - Tray 2
 - jams 192
 - loading 25
 - loading labels 39
 - trays
 - capacity 8
 - included 8
 - locating 3
 - troubleshooting
 - check cartridge status 212
 - jams 186
 - network problems 236
 - paper feed problems 177
 - wired network 236
 - wireless network 238
 - troubleshooting tools
 - HP Embedded Web Server 147
 - two-sided printing
 - settings (Windows) 62
- U**
- USB
 - sending to 124
 - USB port
 - enabling 76
 - locating 4
 - USB storage accessories
 - printing from 76
- W**
- Web browser requirements
 - HP Embedded Web Server 142
 - Web sites
 - customer support 172
 - HP Web Jetadmin, downloading 168
 - weight, printer 12
 - Wi-Fi Direct Print 12, 72
 - wireless network
 - troubleshooting 238
 - wireless network interference 241