

IBM System x3250 M4 Type 2583



Installation and User's Guide

IBM System x3250 M4 Type 2583



Installation and User's Guide

Note: Before using this information and the product it supports, read the general information in Appendix B, "Notices," on page 75, the *IBM Safety Information and Environmental Notices and User Guide* documents on the *IBM Documentation CD*, and the *Warranty Information*.

The most recent version of this document is available at <http://www.ibm.com/systems/support/>.

Second Edition (October 2011)

© Copyright IBM Corporation 2011.

US Government Users Restricted Rights – Use, duplication or disclosure restricted by GSA ADP Schedule Contract with IBM Corp.

Contents

Safety	vii
Chapter 1. The System x3250 M4 server	1
The IBM System x Documentation CD	2
Hardware and software requirements	2
Using the Documentation Browser	2
Related documentation	3
Notices and statements in this document	4
Features and specifications	5
What your server offers	7
Reliability, availability, and serviceability	9
IBM Systems Director	10
The UpdateXpress System Packs	11
Server controls, LEDs, and power	11
Front view	11
Rear view	13
Server power features	14
Chapter 2. Installing optional devices.	17
Instructions for IBM Business Partners	17
Server components	18
System-board internal connectors	20
System-board external connectors	21
System-board jumpers	22
System-board LEDs	24
PCI riser-card assembly connectors	25
Installation guidelines	25
System reliability guidelines	26
Working inside the server with the power on	26
Handling static-sensitive devices	27
Removing the server top cover	27
Removing the air baffle	28
Removing the PCI riser-card assembly	29
Memory module	30
Unbuffered DIMMs (UDIMMs)	31
Installing a memory module	32
Installing drives	34
Installing a simple-swap hard disk drive	34
Installing a hot-swap hard disk drive	35
Installing an optional DVD drive	36
Installing an adapter	39
Installing a ServeRAID adapter	41
Installing a hot-swap power supply	43
Installing a USB embedded hypervisor flash device	44
Completing the installation	45
Replacing the PCI riser-card assembly	45
Replacing the air baffle	46
Replacing the server top cover	47
Connecting the cables	48
Updating the server configuration	49
Chapter 3. Configuring the server	51
Using the Setup utility	52

Starting the Setup utility	52
Setup utility menu choices	52
Passwords	55
Using the Boot Manager program	57
Starting the backup server firmware	57
Using the ServerGuide Setup and Installation CD	57
ServerGuide features	58
Setup and configuration overview	58
Typical operating-system installation	59
Installing your operating system without using ServerGuide	59
Using the integrated management module II (IMM2)	59
Using IPMItool	60
Managing tools and utilities with IMM2 and IBM System x Server Firmware	60
Using IBM Advanced Settings Utility (ASU)	60
Using IBM Flash utilities and update utilities	60
Resetting the IMM2 with the Setup utility	61
LAN over USB	62
Potential conflicts with the LAN over USB interface	62
Resolving conflicts with the IMM2 LAN over USB interface	62
Configuring the LAN over USB interface manually	62
Installing device drivers	62
Using the embedded hypervisor	64
Enabling the Intel Gigabit Ethernet Utility program	65
Configuring the Gigabit Ethernet controller	65
Enabling and configuring Serial over LAN (SOL)	65
UEFI update and configuration	66
Using the LSI Configuration Utility program	66
Starting the LSI Configuration Utility program	67
Formatting a hard disk drive	68
Creating a RAID array of hard disk drives	68
Creating a software RAID array of hard disk drives	68
Disable a software RAID array of hard disk drives	69
IBM Advanced Settings Utility program	70
Updating IBM Systems Director	70
Appendix A. Getting help and technical assistance	73
Before you call	73
Using the documentation	73
Getting help and information from the World Wide Web	73
Software service and support	74
Hardware service and support	74
IBM Taiwan product service	74
Appendix B. Notices	75
Trademarks	75
Important notes	76
Particulate contamination	77
Documentation format	77
Telecommunication regulatory statement	78
Electronic emission notices	78
Federal Communications Commission (FCC) statement	78
Industry Canada Class A emission compliance statement	78
Avis de conformité à la réglementation d'Industrie Canada	78
Australia and New Zealand Class A statement	78
European Union EMC Directive conformance statement	79
Germany Class A statement	79

VCCI Class A statement	80
Japan Electronics and Information Technology Industries Association (JEITA) statement	80
Korean Class A warning statement	80
Russia Electromagnetic Interference (EMI) Class A statement.	81
People's Republic of China Class A electronic emission statement	81
Taiwan Class A compliance statement	81
Index	83

Safety

Before installing this product, read the Safety Information.

قبل تركيب هذا المنتج، يجب قراءة الملاحظات الأمنية

Antes de instalar este produto, leia as Informações de Segurança.

在安装本产品之前，请仔细阅读 **Safety Information** (安全信息)。

安裝本產品之前，請先閱讀「安全資訊」。

Prije instalacije ovog produkta obavezno pročitajte Sigurnosne Upute.

Před instalací tohoto produktu si přečtěte příručku bezpečnostních instrukcí.

Læs sikkerhedsforskrifterne, før du installerer dette produkt.

Lees voordat u dit product installeert eerst de veiligheidsvoorschriften.

Ennen kuin asennat tämän tuotteen, lue turvaohjeet kohdasta Safety Information.

Avant d'installer ce produit, lisez les consignes de sécurité.

Vor der Installation dieses Produkts die Sicherheitshinweise lesen.

Πριν εγκαταστήσετε το προϊόν αυτό, διαβάστε τις πληροφορίες ασφάλειας (safety information).

לפני שתתקינו מוצר זה, קראו את הוראות הבטיחות.

A termék telepítése előtt olvassa el a Biztonsági előírásokat!

Prima di installare questo prodotto, leggere le Informazioni sulla Sicurezza.

製品の設置の前に、安全情報をお読みください。

본 제품을 설치하기 전에 안전 정보를 읽으십시오.

Пред да се инсталира овој продукт, прочитајте информацијата за безбедност.

Les sikkerhetsinformasjonen (Safety Information) før du installerer dette produktet.

Przed zainstalowaniem tego produktu, należy zapoznać się z książką "Informacje dotyczące bezpieczeństwa" (Safety Information).

Antes de instalar este produto, leia as Informações sobre Segurança.

Перед установкой продукта прочтите инструкции по технике безопасности.

Pred inštaláciou tohto zariadenia si pečítajte Bezpečnostné predpisy.

Pred namestitvijo tega proizvoda preberite Varnostne informacije.

Antes de instalar este producto, lea la información de seguridad.

Läs säkerhetsinformationen innan du installerar den här produkten.

Important:

Each caution and danger statement in this documentation is labeled with a number. This number is used to cross reference an English language caution or danger statement with translated versions of the caution or danger statement in the *Safety Information* document.

For example, if a caution statement is labeled "Statement 1," translations for that caution statement are in the *Safety Information* document under "Statement 1."

Be sure to read all caution and danger statements in this document before you perform the procedures. Read any additional safety information that comes with the server or optional device before you install the device.

Attention: Use No. 26 AWG or larger UL-listed or CSA certified telecommunication line cord.

Statement 1:



DANGER

Electrical current from power, telephone, and communication cables is hazardous.

To avoid a shock hazard:

- **Do not connect or disconnect any cables or perform installation, maintenance, or reconfiguration of this product during an electrical storm.**
- **Connect all power cords to a properly wired and grounded electrical outlet.**
- **Connect to properly wired outlets any equipment that will be attached to this product.**
- **When possible, use one hand only to connect or disconnect signal cables.**
- **Never turn on any equipment when there is evidence of fire, water, or structural damage.**
- **Disconnect the attached power cords, telecommunications systems, networks, and modems before you open the device covers, unless instructed otherwise in the installation and configuration procedures.**
- **Connect and disconnect cables as described in the following table when installing, moving, or opening covers on this product or attached devices.**

To Connect:

1. Turn everything OFF.
2. First, attach all cables to devices.
3. Attach signal cables to connectors.
4. Attach power cords to outlet.
5. Turn device ON.

To Disconnect:

1. Turn everything OFF.
2. First, remove power cords from outlet.
3. Remove signal cables from connectors.
4. Remove all cables from devices.

Statement 2:



CAUTION:

When replacing the lithium battery, use only IBM Part Number 33F8354 or an equivalent type battery recommended by the manufacturer. If your system has a module containing a lithium battery, replace it only with the same module type made by the same manufacturer. The battery contains lithium and can explode if not properly used, handled, or disposed of.

Do not:

- **Throw or immerse into water**
- **Heat to more than 100°C (212°F)**
- **Repair or disassemble**

Dispose of the battery as required by local ordinances or regulations.

Statement 3:



CAUTION:

When laser products (such as CD-ROMs, DVD drives, fiber optic devices, or transmitters) are installed, note the following:

- Do not remove the covers. Removing the covers of the laser product could result in exposure to hazardous laser radiation. There are no serviceable parts inside the device.
- Use of controls or adjustments or performance of procedures other than those specified herein might result in hazardous radiation exposure.



DANGER

Some laser products contain an embedded Class 3A or Class 3B laser diode. Note the following.

Laser radiation when open. Do not stare into the beam, do not view directly with optical instruments, and avoid direct exposure to the beam.



Class 1 Laser Product
Laser Klasse 1
Laser Klass 1
Luokan 1 Laserlaite
Appareil À Laser de Classe 1

Statement 4:



≥ 18 kg (39.7 lb.)



≥ 32 kg (70.5 lb.)

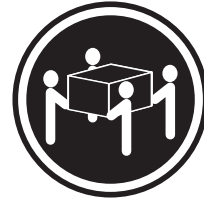

≥ 55 kg (121.2 lb.)

CAUTION:

Use safe practices when lifting.

Statement 5:



CAUTION:

The power control button on the device and the power switch on the power supply do not turn off the electrical current supplied to the device. The device also might have more than one power cord. To remove all electrical current from the device, ensure that all power cords are disconnected from the power source.



Statement 6:



CAUTION:

Do not place any objects on top of a rack-mounted device unless that rack-mounted device is intended for use as a shelf.

Statement 8:



CAUTION:

Never remove the cover on a power supply or any part that has the following label attached.



Hazardous voltage, current, and energy levels are present inside any component that has this label attached. There are no serviceable parts inside these components. If you suspect a problem with one of these parts, contact a service technician.

Statement 12:



CAUTION:

The following label indicates a hot surface nearby.



Statement 13:



DANGER

Overloading a branch circuit is potentially a fire hazard and a shock hazard under certain conditions. To avoid these hazards, ensure that your system electrical requirements do not exceed branch circuit protection requirements. Refer to the information that is provided with your device for electrical specifications.

Statement 26:



CAUTION:

Do not place any object on top of rack-mounted devices.



This server is suitable for use on an IT power-distribution system whose maximum phase-to-phase voltage is 240 V under any distribution fault condition.

Statement 27:



CAUTION:

Hazardous moving parts are nearby.



Chapter 1. The System x3250 M4 server

This *Installation and User's Guide* contains information and instructions for setting up your IBM System x3250 M4 Type 2583 server, instructions for installing some optional devices, and instructions for cabling, and configuring the server. For removing and installing optional devices, diagnostics and troubleshooting information, see the *Problem Determination and Service Guide* on the IBM System x Documentation CD, which comes with the server.

In addition to the instructions in Chapter 2, "Installing optional devices," on page 17 for installing optional hardware devices, updating firmware and device drivers, and completing the installation, IBM Business Partners must also complete the steps in "Instructions for IBM Business Partners" on page 17.

The IBM® System x3250 M4 Type 2583 server is a 1U-high¹ rack model server for high-volume network transaction processing. This high-performance, dual-core or quad-core server is ideally suited for networking environments that require superior microprocessor performance, input/output (I/O) flexibility, and high manageability.

Performance, ease of use, reliability, and expansion capabilities were key considerations in the design of the server. These design features make it possible for you to customize the system hardware to meet your needs today and provide flexible expansion capabilities for the future.

The server comes with a limited warranty. For information about the terms of the warranty and getting service and assistance, see the printed *Warranty Information* document that comes with your server.

The server contains IBM X-Architecture® technologies, which help increase performance and reliability. For more information, see "What your server offers" on page 7 and "Reliability, availability, and serviceability" on page 9.

You can obtain up-to-date information about the server and other IBM server products at <http://www.ibm.com/systems/x/>. At <http://www.ibm.com/support/mysupport/>, you can create a personalized support page by identifying IBM products that are of interest to you. From this personalized page, you can subscribe to weekly e-mail notifications about new technical documents, search for information and downloads, and access various administrative services.

If you participate in the IBM client reference program, you can share information about your use of technology, best practices, and innovative solutions; build a professional network; and gain visibility for your business. For more information about the IBM client reference program, see <http://www.ibm.com/ibm/clientreference/>.

If firmware and documentation updates are available, you can download them from the IBM website. The server might have features that are not described in the documentation that comes with the server, and the documentation might be updated occasionally to include information about those features, or technical updates might be available to provide additional information that is not included in the server documentation. To check for updates, go to <http://www.ibm.com/supportportal/>.

1. Racks are marked in vertical increments of 1.75 inches each. Each increment is referred to as a unit, or a "U". A 1U-high device is approximately 1.75 inches tall.

Record information about the server in the following table.

Product name	IBM System x3250 M4
Machine type	2583
Model number	_____
Serial number	_____

The model number and serial number are on the ID label on the front of the server.

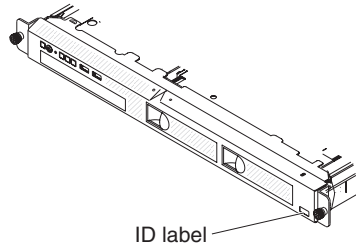

Note: The illustrations in this document might differ slightly from your hardware.

You can download an IBM *ServerGuide Setup and Installation* CD to help you configure the hardware, install device drivers, and install the operating system.

For a list of supported optional devices for the server, see <http://www.ibm.com/servers/eserver/serverproven/compat/us/>.

See the *Rack Installation Instructions* document on the IBM *System x Documentation* CD for complete rack installation and removal instructions.

The IBM System x Documentation CD

The IBM *System x Documentation* CD contains documentation for the server in Portable Document Format (PDF) and includes the IBM Documentation Browser to help you find information quickly.

Hardware and software requirements

The IBM *System x Documentation* CD requires the following minimum hardware and software:

- Microsoft Windows XP, Windows 2000, or Red Hat Linux
- 100 MHz microprocessor
- 32 MB of RAM
- Adobe Acrobat Reader 3.0 (or later) or xpdf, which comes with Linux operating systems

Using the Documentation Browser

Use the Documentation Browser to browse the contents of the CD, read brief descriptions of the documents, and view documents, using Adobe Acrobat Reader or xpdf. The Documentation Browser automatically detects the regional settings in use in your server and displays the documents in the language for that region (if available). If a document is not available in the language for that region, the English-language version is displayed.

Use one of the following procedures to start the Documentation Browser:

- If Autostart is enabled, insert the CD into the CD or DVD drive. The Documentation Browser starts automatically.
- If Autostart is disabled or is not enabled for all users, use one of the following procedures:

- If you are using a Windows operating system, insert the CD into the CD or DVD drive and click **Start -> Run**. In the **Open** field, type
`e:\win32.bat`

where *e* is the drive letter of the CD or DVD drive, and click **OK**.

- If you are using Red Hat Linux, insert the CD into the CD or DVD drive; then, run the following command from the `/mnt/cdrom` directory:
`sh runlinux.sh`

Select the server from the **Product** menu. The **Available Topics** list displays all the documents for the server. Some documents might be in folders. A plus sign (+) indicates each folder or document that has additional documents under it. Click the plus sign to display the additional documents.

When you select a document, a description of the document is displayed under **Topic Description**. To select more than one document, press and hold the Ctrl key while you select the documents. Click **View Book** to view the selected document or documents in Acrobat Reader or xpdf. If you selected more than one document, all the selected documents are opened in Acrobat Reader or xpdf.

To search all the documents, type a word or word string in the **Search** field and click **Search**. The documents in which the word or word string appears are listed in order of the most occurrences. Click a document to view it, and press Ctrl+F to use the Acrobat search function, or press Alt+F to use the xpdf search function within the document.

Click **Help** for detailed information about using the Documentation Browser.

Related documentation

This *Installation and User's Guide* contains general information about the server including how to set up and cabling the server, how to install supported optional devices, and how to configure the server. The following documentation also comes with the server:

- *Problem Determination and Service Guide*

This document is in PDF on the IBM *System x Documentation* CD. It contains information to help you solve problems yourself, and it contains information for service technicians.

- *IBM Warranty Information*

This printed document contains the warranty terms and a pointer to the IBM Statement of Limited Warranty on the IBM website.

- *Rack Installation Instructions*

This printed document contains instructions for installing the server in a rack and comes with the rack kit.

- *Environmental Notices and User Guide*

This document is in PDF format on the IBM *System x Documentation* CD. It contains translated environmental notices.

- *Safety Information*

This document is in PDF on the IBM *System x Documentation* CD. It contains translated caution and danger statements. Each caution and danger statement that appears in the documentation has a number that you can use to locate the corresponding statement in your language in the *Safety Information* document.

- *IBM License Agreement for Machine Code*

This document is in PDF. It provides translated versions of the *IBM License Agreement for Machine Code* for your product.

Depending on the server model, additional documentation might be included on the IBM *System x Documentation* CD.

The ToolsCenter for System x and BladeCenter is an online information center that contains information about tools for updating, managing, and deploying firmware, device drivers, and operating systems. The ToolsCenter for System x and BladeCenter is at <http://publib.boulder.ibm.com/infocenter/toolsctr/v1r0/index.jsp>.

The server might have features that are not described in the documentation that comes with the server. The documentation might be updated occasionally to include information about those features, or technical updates might be available to provide additional information that is not included in the server documentation. To check for updated documentation and technical updates, go to <http://www.ibm.com/supportportal/>.

Notices and statements in this document

The caution and danger statements in this document are also in the multilingual *Safety Information* document, which is on the IBM *System x Documentation* CD. Each statement is numbered for reference to the corresponding statement in your language in the *Safety Information* document.

The following notices and statements are used in this document:

- **Note:** These notices provide important tips, guidance, or advice.
- **Important:** These notices provide information or advice that might help you avoid inconvenient or problem situations.
- **Attention:** These notices indicate potential damage to programs, devices, or data. An attention notice is placed just before the instruction or situation in which damage might occur.
- **Caution:** These statements indicate situations that can be potentially hazardous to you. A caution statement is placed just before the description of a potentially hazardous procedure step or situation.
- **Danger:** These statements indicate situations that can be potentially lethal or extremely hazardous to you. A danger statement is placed just before the description of a potentially lethal or extremely hazardous procedure step or situation.

Features and specifications

The following information is a summary of the features and specifications of the server. Depending on the model, some features might not be available, or some specifications might not apply.

Table 1. Features and specifications

<p>Microprocessor:</p> <ul style="list-style-type: none"> • Supports one Intel quad-core or dual-core processor • Multi-chip Package processor architecture • Designed for LGA 1155 socket • Scalable up to four cores • 32 KB instruction L1 cache, 32 KB data L1 cache, 256 KB instruction/data L2 cache, and up to 6 MB L3 cache that is shared among the cores • Support for Intel Extended Memory 64 Technology (EM64T) <p>Note:</p> <ul style="list-style-type: none"> • Use the Setup utility to determine the type and speed of the microprocessor. • For a list of supported microprocessors, see http://www.ibm.com/servers/eserver/serverproven/compat/us/. <p>Memory:</p> <ul style="list-style-type: none"> • Minimum: 1 GB • Maximum: 32 GB • Types: PC3-10600 (single-rank or dual-rank), 1333 MHz, ECC, DDR3 unbuffered SDRAM DIMMs only • Connectors: Four dual inline memory module (DIMM) connectors, two-way interleaved • Sizes: 1 GB (single-rank), 2 GB (single-rank), 4 GB (dual-rank), and 8 GB (dual-rank) 	<p>SATA optical drives (optional):</p> <ul style="list-style-type: none"> • UltraSlim DVD-ROM combo • Multi-burner <p>Hard disk drive expansion bays (depending on the model):</p> <p>One of the following configurations:</p> <ul style="list-style-type: none"> • Four 2.5-inch simple-swap SAS hard disk drive bays • Four 2.5-inch hot-swap SAS hard disk drive bays • Two 3.5-inch simple-swap SATA hard disk drive bays <p>Note: 3TB hard disk drives are not supported in OS 4690.</p> <p>PCI expansion slots:</p> <p>Supports two PCI riser slots on the riser card:</p> <ul style="list-style-type: none"> • Slot 1 is dedicated for ServeRAID-10i1 V2 SAS/SATA controller • Slot 2 supports one PCI Express Gen3 x8 half-length, full-height adapter <p>Power supply (depending on the model):</p> <ul style="list-style-type: none"> • One fixed 300-watt power supply • Up to two hot-swap 460-watt power supplies for redundancy <p>Fans: The server comes standard with four speed-controlled fans.</p>	<p>Integrated functions:</p> <ul style="list-style-type: none"> • integrated management module II (IMM2), which consolidates multiple management functions in a single chip • Intel 82574L Gb Ethernet controller with TCP/IP Offload Engine (TOE) and Wake on LAN support • Six Universal Serial Bus (USB) 2.0 ports (two front and four rear) • Two Ethernet ports • Six-port integrated SATA controller • One serial port • One VGA port
---	--	---

Table 1. Features and specifications (continued)

<p>RAID controllers (depending on the model):</p> <ul style="list-style-type: none"> • Software RAID capabilities that support RAID levels 0, 1, and 10 • ServeRAID-BR10iL v2 SAS/SATA adapter that provides RAID levels 0, 1, and 10 <p>Acoustical noise emissions:</p> <ul style="list-style-type: none"> • Sound power, idling: 6.5 bels maximum • Sound power, operating: 6.5 bels maximum <p>Environment:</p> <ul style="list-style-type: none"> • Air temperature: <ul style="list-style-type: none"> – Server on: 10°C to 35°C (50.0°F to 95.0°F); altitude: 0 to 914.4 m (3000 ft) – Server on: 10°C to 32°C (50.0°F to 89.6°F); altitude: 914.4 m (3000 ft) to 2133.6 m (7000 ft) – Server on: 10°C to 28°C (50.0°F to 83°F); altitude: 2133.6 m (7000 ft) to 3050 m (10000 ft) – Server off: 10°C to 43°C (50°F to 109.4°F); maximum altitude: 2133.6 m (7000.0 ft) – Shipping: -40°C to 60°C (-104°F to 140°F) • Humidity: <ul style="list-style-type: none"> – Server on: 8% to 80% – Server off: 8% to 80% • Particulate contamination: <p>Attention: Airborne particulates and reactive gases acting alone or in combination with other environmental factors such as humidity or temperature might pose a risk to the server. For information about the limits for particulates and gases, see “Particulate contamination” on page 77.</p> 	<p>Video controller (integrated into IMM2):</p> <ul style="list-style-type: none"> • Matrox G200 • SVGA compatible video controller • Avocent Digital Video Compression • Video memory is not expandable <p>Note: Maximum video resolution is 1600 x 1200 at 75 Hz.</p> <p>Size:</p> <ul style="list-style-type: none"> • 1U • Height: 43 mm (1.69 inches) • Depth: 575.8 mm (22.67 inches) • Width: <ul style="list-style-type: none"> – 439 mm (17.28 inches) (without rack brackets) – 478 mm (18.82 inches) (with rack brackets) • Maximum weight: 10.67 kg (23.53 lb) depending on your configuration <p>Heat output:</p> <p>Approximate heat output:</p> <ul style="list-style-type: none"> • Minimum configuration: 150 BTU per hour (44 watts) • Maximum configuration: 1421 BTU per hour (416 watts) <p>Electrical input:</p> <ul style="list-style-type: none"> • Sine-wave input (50 / 60 Hz) required • Input voltage low range: <ul style="list-style-type: none"> – Minimum: 100 V ac – Maximum: 127 V ac • Input voltage high range: <ul style="list-style-type: none"> – Minimum: 200 V ac – Maximum: 240 V ac • Input kilovolt-amperes (kVA), approximately: <ul style="list-style-type: none"> – Minimum: 0.044 kVA – Maximum: 0.416 kVA 	<p>Notes:</p> <ol style="list-style-type: none"> 1. Power consumption and heat output vary depending on the number and type of optional features installed and the power-management optional features in use. 2. The sound levels were measured in controlled acoustical environments according to the procedures specified by the American National Standards Institute (ANSI) S12.10 and ISO 7779 and are reported in accordance with ISO 9296. Actual sound-pressure levels in a given location might exceed the average values stated because of room reflections and other nearby noise sources. The noise emission level stated in the declared (upper limit) sound-power level, in bels, for a random sample of system. 3. There is no keyboard connector or mouse connector on the server. You can connect a USB keyboard and USB mouse to the server by using the USB connectors.
--	--	--

What your server offers

The server uses the following features and technologies:

- **integrated management module II**

The integrated management module II (IMM2) is the second generation of the IMM. The IMM2 is the common management controller for IBM System x hardware. The IMM2 consolidates multiple management functions in a single chip on the server system board.

Some of the features that are unique to the IMM2 are enhanced performance, expanded compatibility with blade servers, higher-resolution remote video, expanded security options, and Feature on Demand enablement for hardware and firmware options.

For additional information, see “Using the integrated management module II (IMM2)” on page 59.

- **UEFI-compliant server firmware**

The UEFI firmware offers several features, including Unified Extensible Firmware Interface (UEFI) version 2.1 compliance; enhanced reliability, availability, and serviceability (RAS) capabilities; and basic input/output system (BIOS) compatibility support. UEFI replaces the BIOS and defines a standard interface between the operating system, platform firmware, and external devices. The server is capable of booting UEFI-compliant operating systems, BIOS-based operating systems, and BIOS-based adapters as well as UEFI-compliant adapters.

Note: The server does not support DOS.

- **VMware ESXi embedded hypervisor**

The VMware ESXi embedded hypervisor is available on server models that come with an installed USB embedded hypervisor flash device. The hypervisor flash device is installed in the USB connector on the system board. Hypervisor is virtualization software that enables multiple operating systems to run on a host server at the same time.

- **Dynamic System Analysis (DSA)**

Dynamic System Analysis (DSA) collects and analyzes system information to aid in diagnosing server problems. DSA collects the following information about the server:

- Drive health information
- Event logs for ServeRAID controllers and service processors
- Hardware inventory, including PCI and USB information
- Installed applications and hot fixes
- Kernel modules
- Light path diagnostics status
- Network interfaces and settings
- Performance data and details about processes that are running
- RAID and controller configuration
- integrated management module II (IMM2) status and configuration
- System configuration
- Vital product data and firmware information

DSA creates a DSA log, which is a chronologically ordered merge of the system-event log (as the IPMI event log), the integrated management module II (IMM2) event log (as the ASM event log), and the operating-system event logs. You can send the DSA log as a file to a support representative or view the information as a text file or HTML file. For more information, see the *Problem Determination and Service Guide*.

- **Dual-core or quad-core processing**

The server supports one Intel Xeon dual-core or quad-core microprocessor.

- **Integrated network support**

The server comes with an integrated Intel Gigabit Ethernet controller, which supports connection to a 10 Mbps, 100 Mbps, or 1000 Mbps network. For more information, see “Configuring the Gigabit Ethernet controller” on page 65.

- **Large system-memory capacity**

The memory bus supports up to 32 GB of memory when unbuffered DIMMs are installed. The memory controller supports error correcting code (ECC) for up to four industry-standard PC3-10600R-999, 1066 and 1333 MHz, DDR3 (third-generation double-data-rate), unbuffered, synchronous dynamic random access memory (SDRAM) dual inline memory modules (DIMMs).

- **Large data-storage capacity**

The server supports a maximum of four 2.5-inch simple-swap Serial Attached SCSI (SAS) or Serial ATA (SATA) hard disk drives or two 3.5-inch simple-swap SATA hard disk drives, depending on the server model.

- **PCI adapter capabilities**

The server has two PCI interface slots on the riser card (one supports low-profile adapters, and one supports full-height, half-length adapters). See “Installing an adapter” on page 39 for detailed information.

- **RAID support**

Depending on the model, your server implements redundant array of independent disks (RAID) through software or hardware.

The server supports software RAID capability that provides RAID levels 0 and 1.

The server implements redundant array of independent disks (RAID). Depending on your server models, the server supports the ServeRAID-BR10i1 v2 adapter that provides hardware RAID and provides RAID levels 0 and 1.

- **TCP/IP offload engine (TOE) support**

The Ethernet controllers in the server support TOE, which is a technology that offloads the TCP/IP flow from the microprocessor and I/O subsystem to increase the speed of the TCP/IP flow. When an operating system that supports TOE is running on the server and TOE is enabled, the server supports TOE operation. See the operating-system documentation for information about enabling TOE.

Note: As of the date of this document, the Linux operating system does not support TOE.

- **IBM Systems Director CD**

IBM Systems Director is a workgroup-hardware-management tool that you can use to centrally manage System x and xSeries servers. For more information, see the IBM Systems Director documentation on the *IBM Systems Director CD* and “IBM Systems Director” on page 10.

- **IBM *ServerGuide Setup and Installation* CD**

The *ServerGuide Setup and Installation* CD, which you can download from the web, provides programs to help you set up the server and install a Windows operating system. The ServerGuide program detects installed optional hardware devices and provides the correct configuration programs and device drivers. For more information about the *ServerGuide Setup and Installation* CD, see “Using the ServerGuide Setup and Installation CD” on page 57.

- **Redundant power capabilities**

Depending on the server model, the server supports up to two hot-swap power supplies, which provide redundant power for many server configurations.

Reliability, availability, and serviceability

Three important computer design features are reliability, availability, and serviceability (RAS). The RAS features help to ensure the integrity of the data that is stored in the server, the availability of the server when you need it, and the ease with which you can diagnose and correct problems.

Your server has the following RAS features:

- 3-year parts and 3-year labor limited warranty (Machine Type 2583)
- Automatic error retry and recovery
- Automatic restart on nonmaskable interrupt (NMI)
- Automatic restart after a power failure
- Advanced Configuration and Power Interface (ACPI)
- Advanced Desktop Management Interface (DMI) features
- Intelligent Platform Management Interface (IPMI) 2.0 support that provides secure remote power on/power off and seven standard alerts for components such as fans, voltage, and thermals
- Auto-restart initial program load (IPL)
- Boot-block recovery
- Built-in, menu-driven configuration and setup programs
- Backup basic input/output system switching under the control of the integrated management module II (IMM2)
- Built-in monitoring for fan, power, temperature, voltage, and power supply
- Diagnostic support for ServeRAID and Ethernet adapters
- ECC memory
- Error codes and messages
- integrated management module II (IMM2)
- Menu-driven setup, system configuration, and redundant array of independent disks (RAID) configuration programs
- Parity checking on the small computer system interface (SCSI) bus and PCI buses
- Power management: Compliance with Advanced Configuration and Power Interface (ACPI)
- Power-on self-test (POST)
- Predictive Failure Analysis (PFA) alerts on memory, SAS/SATA hard disk drives, fans, and power supplies
- Remote system problem-determination support
- Read-only memory (ROM) checksums
- ROM-based diagnostics

- SDRAM with serial presence detect (SPD)
- Serial Presence Detection (SPD) on memory, VPD, power supply, and hard disk drives backplane
- Single-DIMM isolation of excessive correctable error or multi-bit error by the Unified Extensible Firmware Interface (UEFI)
- Standby voltage for system-management features and monitoring
- Startup (boot) from LAN through remote initial program load (RIPL) or dynamic host configuration protocol/boot protocol (DHCP/BOOTP)
- System auto-configuring from the configuration menu
- System-error logging (POST and IMM2)
- Systems-management monitoring through the Inter-Integrated Circuit (IC) protocol bus
- Upgradeable POST, Unified Extensible Firmware Interface (UEFI), diagnostics, IMM2 firmware, and read-only memory (ROM) resident code, locally or over the LAN
- Vital product data (VPD) on microprocessor, system board, power supply, and SAS/SATA backplane
- Wake on LAN capability

IBM Systems Director

IBM Systems Director is a platform-management foundation that streamlines the way you manage physical and virtual systems and supports multiple operating systems and virtualization technologies in IBM and non-IBM x86 platforms.

Through a single user interface, IBM Systems Director provides consistent views for viewing managed systems, determining how these systems relate to one another, and identifying their statuses, helping to correlate technical resources with business needs. A set of common tasks that are included with IBM Systems Director provides many of the core capabilities that are required for basic management, which means instant out-of-the-box business value. The following common tasks are included:

- Discovery
- Inventory
- Configuration
- System health
- Monitoring
- Updates
- Event notification
- Automation for managed systems

The IBM Systems Director web and command-line interfaces provide a consistent interface that is focused on driving these common tasks and capabilities:

- Discovering, navigating, and visualizing systems on the network with the detailed inventory and relationships to the other network resources
- Notifying users of problems that occur on systems and the ability to isolate the sources of the problems
- Notifying users when systems need updates and distributing and installing updates on a schedule
- Analyzing real-time data for systems and setting critical thresholds that notify the administrator of emerging problems
- Configuring settings of a single system and creating a configuration plan that can apply those settings to multiple systems

- Updating installed plug-ins to add new features and functions to the base capabilities
- Managing the life cycles of virtual resources

For more information about IBM Systems Director, see the documentation on the *IBM Systems Director* CD that comes with the server and the IBM xSeries Systems Management web page at <http://www.ibm.com/systems/management/>, which presents an overview of IBM Systems Management and IBM Systems Director.

The UpdateXpress System Packs

The UpdateXpress System Pack Installer detects supported and installed device drivers and firmware in the server and installs available updates. For additional information and to download the UpdateXpress System Pack Installer, go to the ToolsCenter for System x and BladeCenter at <http://publib.boulder.ibm.com/infocenter/toolscctr/v1r0/index.jsp> and click **UpdateXpress System Pack Installer**.

Server controls, LEDs, and power

This section describes the controls and light-emitting diodes (LEDs) and how to turn the server on and off. For the locations of other LEDs on the system board, see “System-board LEDs” on page 24.

Front view

Note: The illustrations in this document might differ slightly from your hardware. The following illustration shows the controls, LEDs, and connectors on the front of the two 3.5-inch simple-swap hard disk drive model.

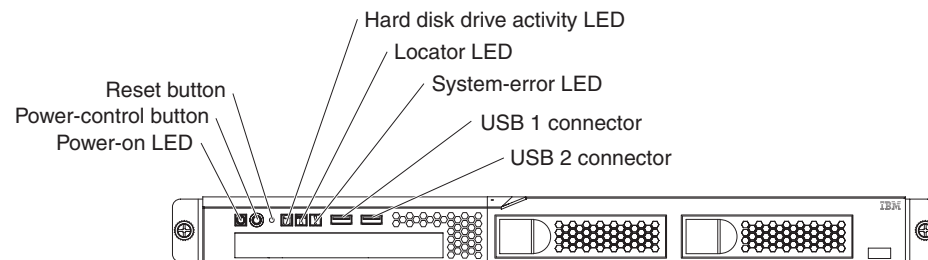

The following illustration shows the controls, LEDs, and connectors on the front of the four 2.5-inch simple-swap hard disk drive model.

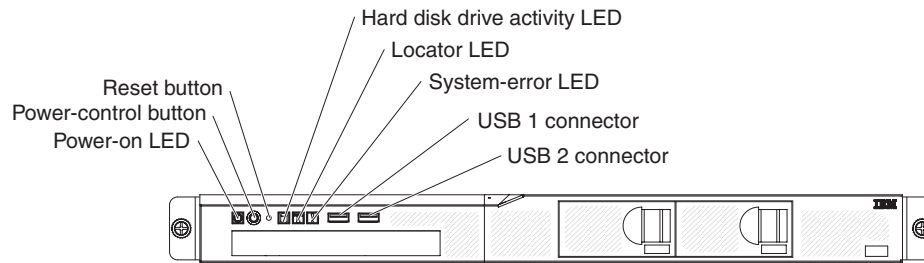

The following illustration shows the controls, LEDs, and connectors on the front of the four 2.5-inch hot-swap hard disk drive model.

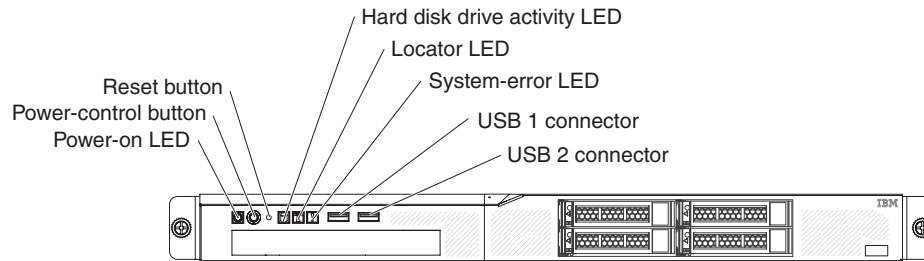

- **Power-on LED:** The states of the power-on LED are as follows:
 - Off:** AC power is not present, or the power supply or the LED itself has failed.
 - Flashing rapidly (4 times per second):** The server is turned off and is not ready to be turned on. The power-control button is disabled. This will last approximately 1 to 3 minutes.
 - Flashing slowly (once per second):** The server is turned off and is ready to be turned on. You can press the power-control button to turn on the server.
 - Lit:** The server is turned on.
 - Fading on and off:** The server is in a reduced-power state. To wake the server, press the power-control button.
- **Power-control button:** Press this button to turn the server on and off manually or to wake the server from a reduced-power state.
- **Reset button:** Press this button to reset the server and run the power-on self-test (POST). You might have to use a pen or the end of a straightened paper clip to press the button.
- **Hard disk drive activity LEDs:** When this LED is flashing, it indicates that the associated hard disk drive is in use.
- **Locator LED:** Use this blue LED to visually locate the server among other servers. This LED is also used as a presence detection button. You can use IBM Systems Director to light this LED remotely. This LED is controlled by the IMM2.
- **System-error LED:** When this amber LED is lit, it indicates that a system error has occurred.
- **USB connectors:** Connect a USB device, such as a USB mouse, keyboard, or other device to any of these connectors.
- **Optional DVD eject button:** Press this button to release a DVD or CD from the optional DVD drive.
- **Optional DVD drive activity LED:** When this LED is lit, it indicates that the optional DVD drive is in use.

- **Hot-swap hard disk drive activity LEDs (some models):** This LED is used on SAS or SATA hard disk drives. Each hot-swap hard disk drive has an activity LED, and when this LED is flashing, it indicates that the drive is in use.
- **Hot-swap hard disk drive status LEDs (some models):** This LED is used on SAS or SATA hard disk drives. When this LED is lit, it indicates that the drive has failed. If an optional IBM ServeRAID controller is installed in the server, when this LED is flashing slowly (one flash per second), it indicates that the drive is being rebuilt. When the LED is flashing rapidly (three flashes per second), it indicates that the controller is identifying the drive.

Rear view

Note: The illustrations in this document might differ slightly from your hardware.

The following illustration shows the LEDs and connectors on the rear of the fixed power-supply model.

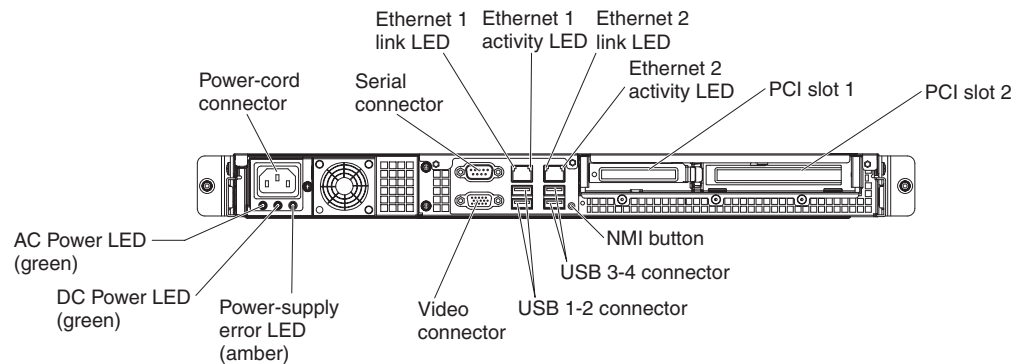

The following illustration shows the LEDs and connectors on the rear of the redundant power-supply model.

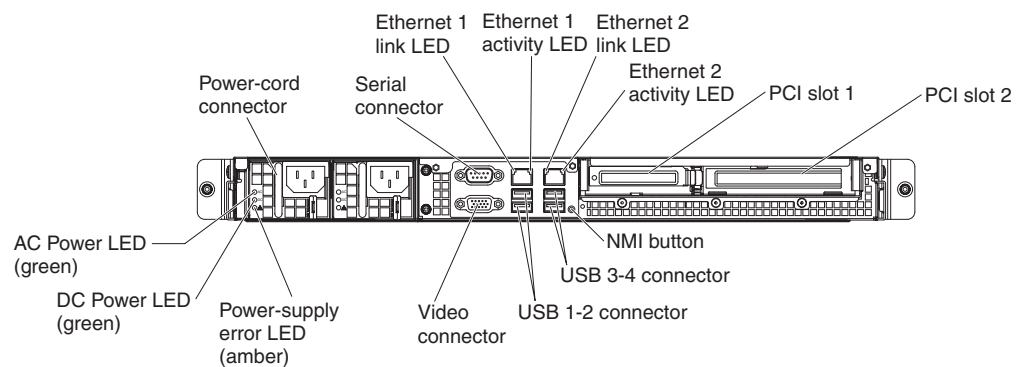

- **Ethernet link LEDs:** When these LEDs are lit, they indicate that there is an active link connection on the 10BASE-T, 100BASE-TX, or 1000BASE-TX interface for the Ethernet port.
- **Ethernet activity LEDs:** When these LEDs are lit, they indicate that there is activity between the server and the network.
- **AC power LED:** This LED is used on power supply with Active Energy Manager (AEM). This green LED provides status information about the power supply. During typical operation, both the ac and dc power LEDs are lit. For any other combination of LEDs, see the *Problem Determination and Service Guide* on the IBM System x Documentation CD.

- **DC power LED:** This LED is use on power supply with AEM. This green LED provides status information about the power supply. During typical operation, both the ac and dc power LEDs are lit. For any other combination of LEDs, see the *Problem Determination and Service Guide* on the IBM System x Documentation CD.
- **Power-supply error (!) LED:** When this amber LED is lit, it indicates that the power supply has failed. For any other combination of LEDs, see the *Problem Determination and Service Guide* on the IBM System x Documentation CD.
- **Power cord connector:** Connect the power cord to this connector.
- **Video connector:** Connect a monitor to this connector.
- **Serial connector:** Connect a 9-pin serial device to this connector. The serial port is shared with the integrated management module II (IMM2). The IMM2 can take control of the shared serial port to redirect serial traffic, using Serial over LAN (SOL).
- **USB connectors:** Connect a USB device, such as a USB mouse, keyboard, or other device to any of these connectors.
- **Ethernet connectors:** Use either of these connectors to connect the server to a network. When you use the Ethernet 1 connector, the network can be shared with the IMM2 through a single network cable.
- **NMI button:** Press this button to force a nonmaskable interrupt to the microprocessor. You might have to use a pen or the end of a straightened paper clip to press the button. It allows you to blue screen the server and take a memory dump (use this button only when directed by the IBM service support).

Server power features

When the server is connected to an ac power source but is not turned on, the operating system does not run, and all core logic except for the integrated management module II is shut down; however, the server can respond to requests to IMM2, such as a remote request to turn on the server. The power-on LED flashes to indicate that the server is connected to ac power but is not turned on.

Turning on the server

Approximately 1 to 3 minutes after the server is connected to ac power, the power-control button becomes active (the power-on LED flashes slowly), and one or more fans might start running to provide cooling while the server is connected to power. You can turn on the server by pressing the power-control button.

The server can also be turned on in any of the following ways:

- If a power failure occurs while the server is turned on, the server will restart automatically when power is restored.
- If your operating system supports the Wake on LAN feature, the Wake on LAN feature can turn on the server.

Note: When 4 GB or more of memory (physical or logical) is installed, some memory is reserved for various system resources and is unavailable to the operating system. The amount of memory that is reserved for system resources depends on the operating system, the configuration of the server, and the configured PCI devices.

Turning off the server

When you turn off the server and leave it connected to ac power, the server can respond to requests to IMM2, such as a remote request to turn on the server. While

the server remains connected to ac power, one or more fans might continue to run. To remove all power from the server, you must disconnect it from the power source.

Some operating systems require an orderly shutdown before you turn off the server. See your operating-system documentation for information about shutting down the operating system.

Statement 5:



CAUTION:

The power control button on the device and the power switch on the power supply do not turn off the electrical current supplied to the device. The device also might have more than one power cord. To remove all electrical current from the device, ensure that all power cords are disconnected from the power source.

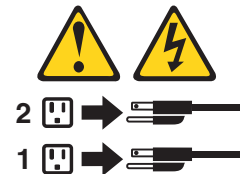

The server can be turned off in any of the following ways:

- You can turn off the server from the operating system, if your operating system supports this feature. After an orderly shutdown of the operating system, the server will turn off automatically.
- You can press the power-control button to start an orderly shutdown of the operating system and turn off the server, if your operating system supports this feature.
- If the operating system stops functioning, you can press and hold the power-control button for more than 4 seconds to turn off the server.
- The server can be turned off by the Shutdown on LAN feature.
- The integrated management module II (IMM2) can turn off the server as an automatic response to a critical system failure.

Chapter 2. Installing optional devices

This chapter provides detailed instructions for installing optional hardware devices in the server.

In addition to the instructions in this chapter for installing optional hardware devices, updating firmware and device drivers, and completing the installation, IBM Business Partners must also complete the steps in “Instructions for IBM Business Partners.”

Important: To help ensure that the devices that you install work correctly and do not introduce problems, observe the following precautions:

1. Make sure that the server and the installed firmware levels support the devices that you are installing. If necessary, update the UEFI and IMM2 firmware and any other firmware that is stored on the system boards. For information about where firmware is stored in the server, see Chapter 6, “Configuration information and instructions,” in the *Problem Determination and Service Guide*. For a list of supported optional devices for the server, see <http://www.ibm.com/systems/info/x86servers/serverproven/compat/us/>.
2. Before you install optional hardware devices, make sure that the server is working correctly. Start the server and make sure that the operating system starts, if an operating system is installed, or that a 19990305 error code is displayed, indicating that an operating system was not found but the server is otherwise working correctly. If the server is not working correctly, see the *Problem Determination and Service Guide* for information about how to run diagnostics.
3. Follow the installation procedures in this chapter and use the correct tools. Incorrectly installed devices can cause system failures because of damaged pins in sockets or connectors, loose cabling, or loose components.
4. Use the best practices to apply current firmware and device-driver updates for the server and optional devices. To download the *IBM System x Firmware Update Best Practices* document, go to <http://www.ibm.com/support/entry/portal/docdisplay?brand=50000020&Indocid=MIGR-5082923>. Additional hints and tips are available from the following sites:
 - IBM support: <http://www.ibm.com/supportportal/>
 - System x configuration tools: <http://www.ibm.com/systems/x/hardware/configtools.html>

Instructions for IBM Business Partners

In addition to the instructions in this chapter for installing optional hardware devices, updating firmware and device drivers, and completing the installation, IBM Business Partners must also complete the following steps:

1. Before you configure a server for a customer, complete the Solution Assurance checklist at <http://w3.ibm.com/support/assure/assur30i.nsf/webindex/sa294/>.
2. After you have confirmed that the server starts correctly and recognizes the newly installed devices and that no error LEDs are lit, run the Dynamic System Analysis (DSA) stress tests. For information about using DSA, see the *Problem Determination and Service Guide*.

3. Shut down and restart the server multiple times to ensure that the server is correctly configured and functions correctly with the newly installed devices.
4. Save the DSA log as a file and send it to IBM.
5. To ship the server, repackage it in the original undamaged packing material and observe IBM procedures for shipping.

Support information for IBM Business Partners is available at <http://www.ibm.com/partnerworld/>.

Server components

The following illustration shows the major components in the server. The illustrations in this document might differ slightly from your hardware.

Model with fixed power supply:

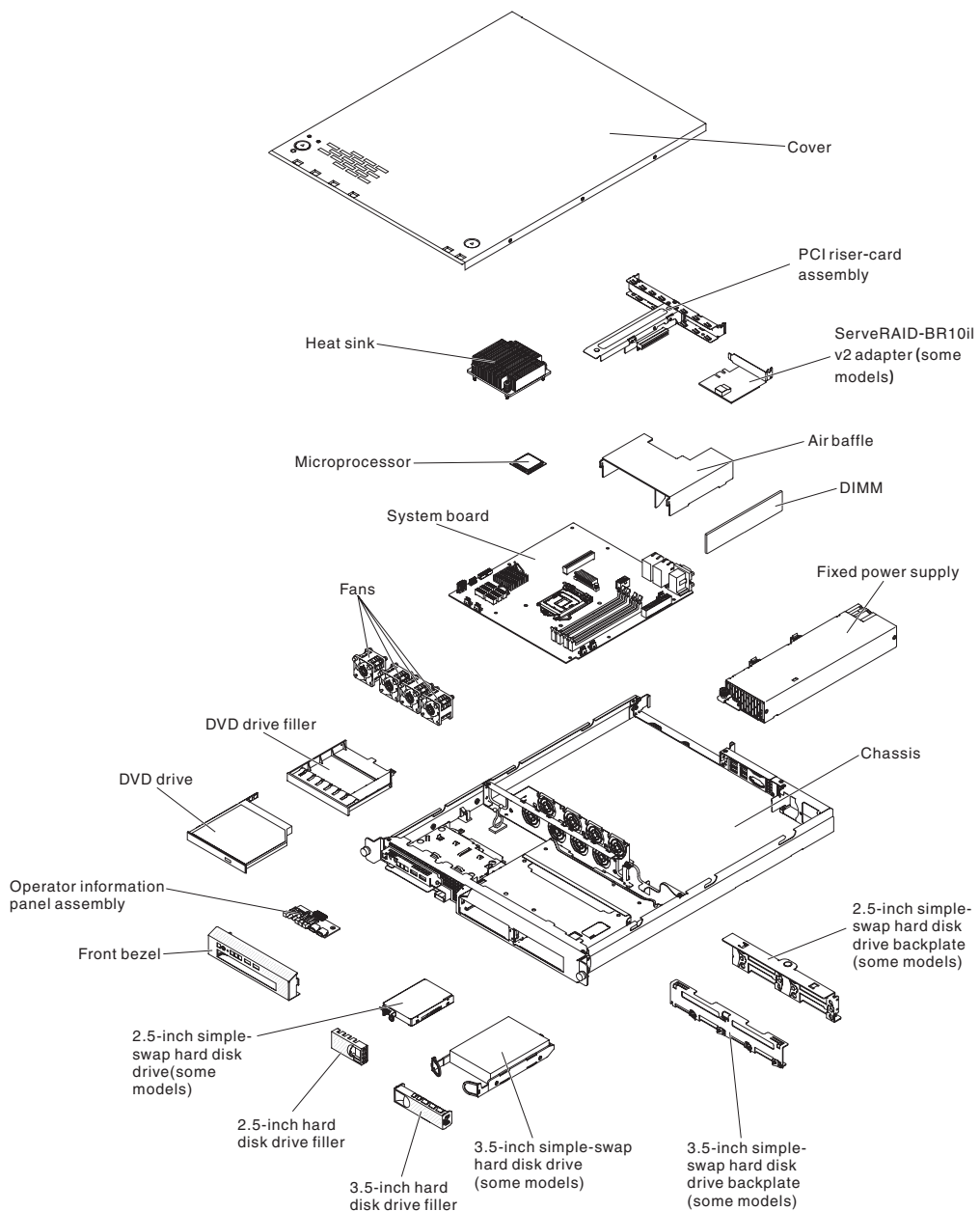

Model with redundant power supply:

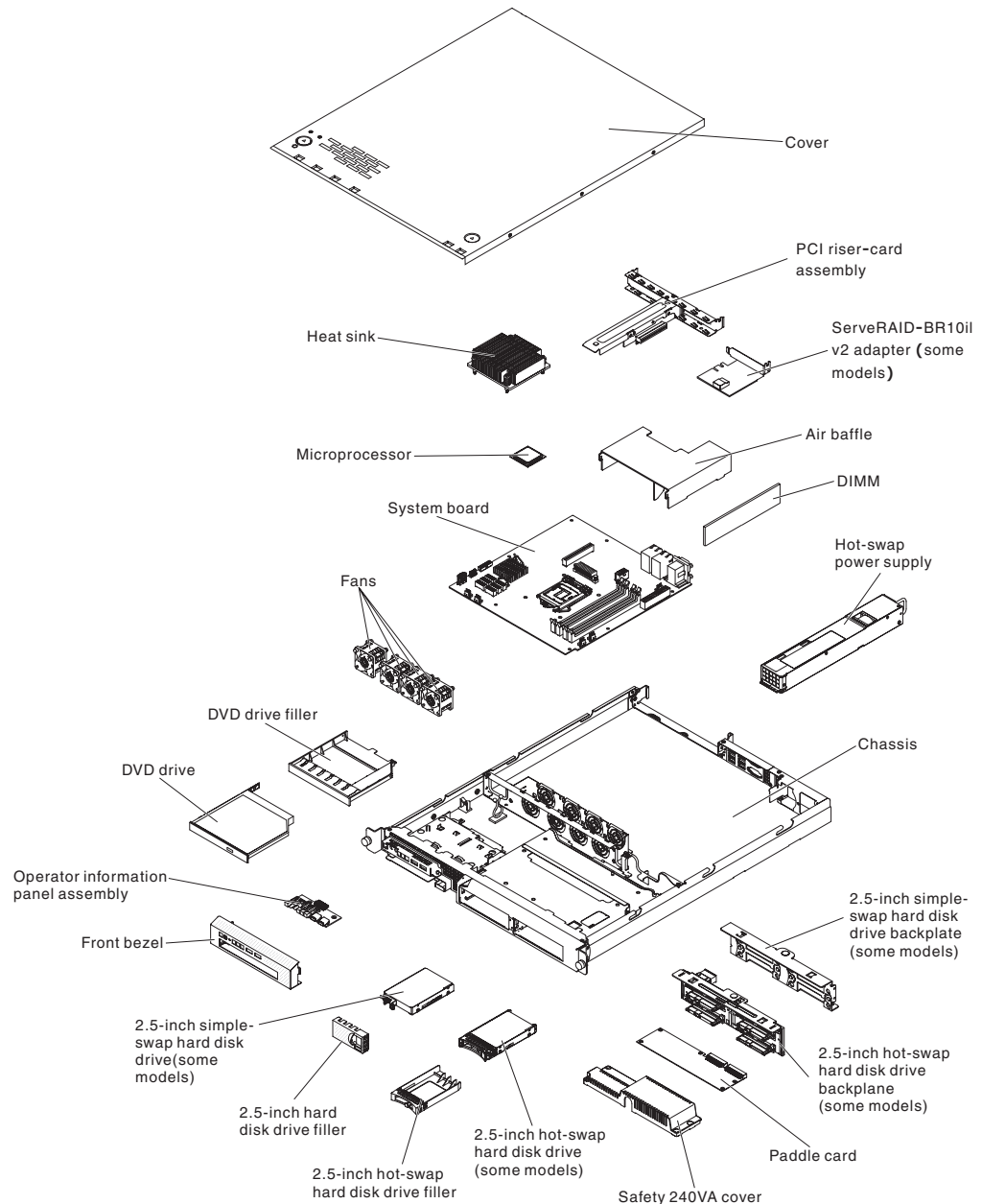

Blue on a component indicates touch points, where you can grip the component to remove it from or install it in the server, open or close a latch, and so on.

Orange on a component or an orange label on or near a component indicates that the component can be hot-swapped, which means that if the server and operating system support hot-swap capability, you can remove or install the component while the server is running. Orange can also indicate touch points on hot-swap components. See the instructions for removing or installing a specific hot-swap component for any additional procedures that you might have to perform before you remove or install the component.

System-board internal connectors

The following illustration shows the internal connectors on the system board.

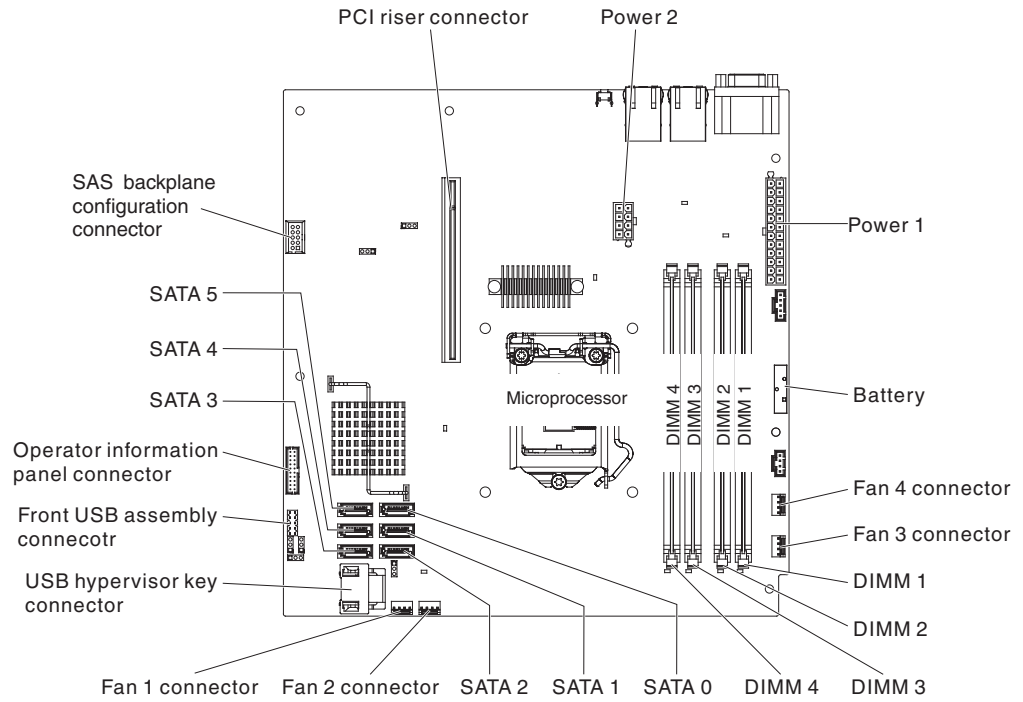

System-board external connectors

The following illustration shows the external input/output connectors on the system board.

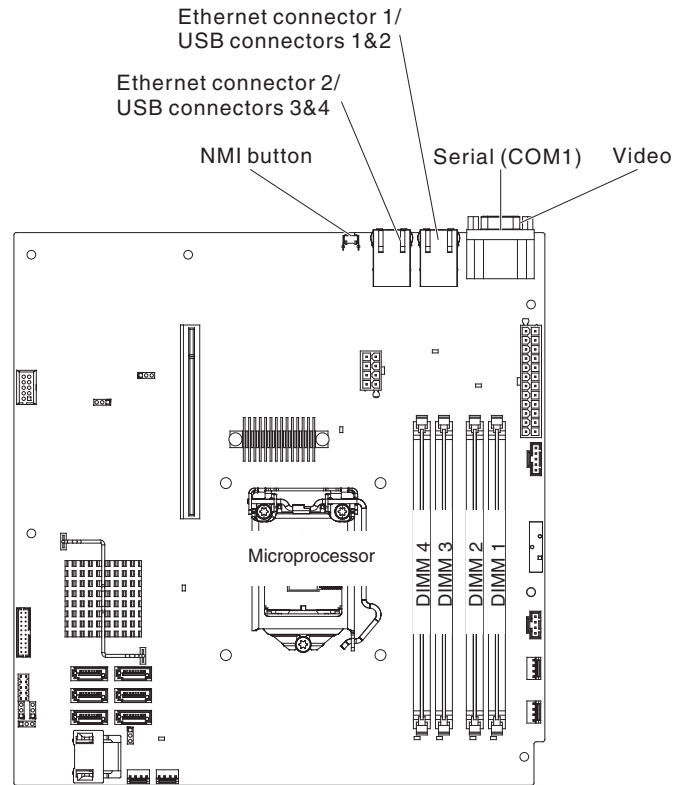

System-board jumpers

The following illustration shows the jumpers on the system board.

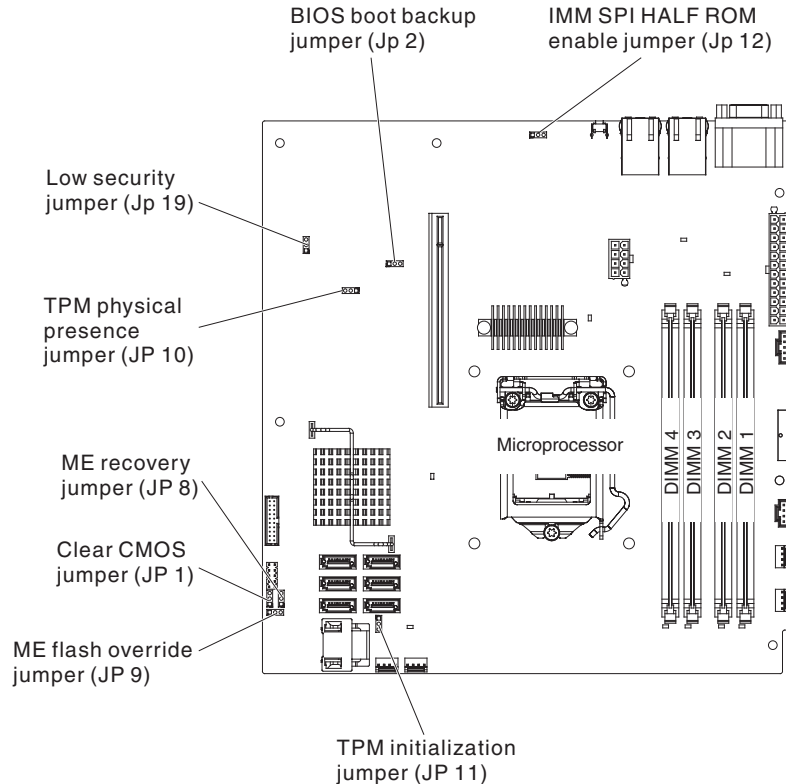

The following table describes the jumpers on the system board.

Table 2. System board jumpers

Jumper number	Jumper name	Jumper setting
JP1	Clear CMOS jumper	<ul style="list-style-type: none"> Pins 1 and 2: Keep CMOS data (default) Pins 2 and 3: Clear CMOS data
JP2	BIOS block backup jumper	<ul style="list-style-type: none"> Pins 1 and 2: Boot from primary BIOS page (default) Pins 2 and 3: Boot from backup BIOS page
JP8	ME recovery jumper	<ul style="list-style-type: none"> Pins 1 and 2: Normal (default). Pins 2 and 3: Activate ME recovery.
JP9	ME flash override jumper	<ul style="list-style-type: none"> Pins 1 and 2: Normal (default). Pins 2 and 3: Override ME flash.
JP10	Trusted Platform Module (TPM) physical presence jumper	<p>Pins 1 and 2: Enable TPM physical presence (default)</p> <p>Pins 2 and 3: Disable TPM physical presence</p>

Table 2. System board jumpers (continued)

Jumper number	Jumper name	Jumper setting
JP11	TPM initialization jumper	<ul style="list-style-type: none"> • Pins 1 and 2: Normal (default). • Pins 2 and 3: Initiate TPM.
JP12	IMM SPI half ROM enable	<ul style="list-style-type: none"> • Pins 1 and 2: Disabled (default). • Pins 2 and 3: Enable IMM SPI half ROM.
JP19	Low security_N jumper	<ul style="list-style-type: none"> • Pins 1 and 2: Normal (default). • Pins 2 and 3: Activate low security.
<p>Notes:</p> <ol style="list-style-type: none"> 1. If no jumper is present, the server responds as if the pins are set to 1 and 2. 2. Changing the position of the boot block jumper from pins 1 and 2 to pins 2 and 3 before the server is turned on alters which flash ROM page is loaded. Do not change the jumper pin position after the server is turned on. This can cause an unpredictable problem. 		

Important:

1. Before you change any switch settings or move any jumpers, turn off the server; then, disconnect all power cords and external cables. Review the information in “Safety” on page vii, “Installation guidelines” on page 25, “Handling static-sensitive devices” on page 27, and “Turning off the server” on page 14.
2. Any system-board switches or jumpers that are not labelled in the illustrations in this document are reserved.

System-board LEDs

The following illustration shows the light-emitting diodes (LEDs) on the system board.

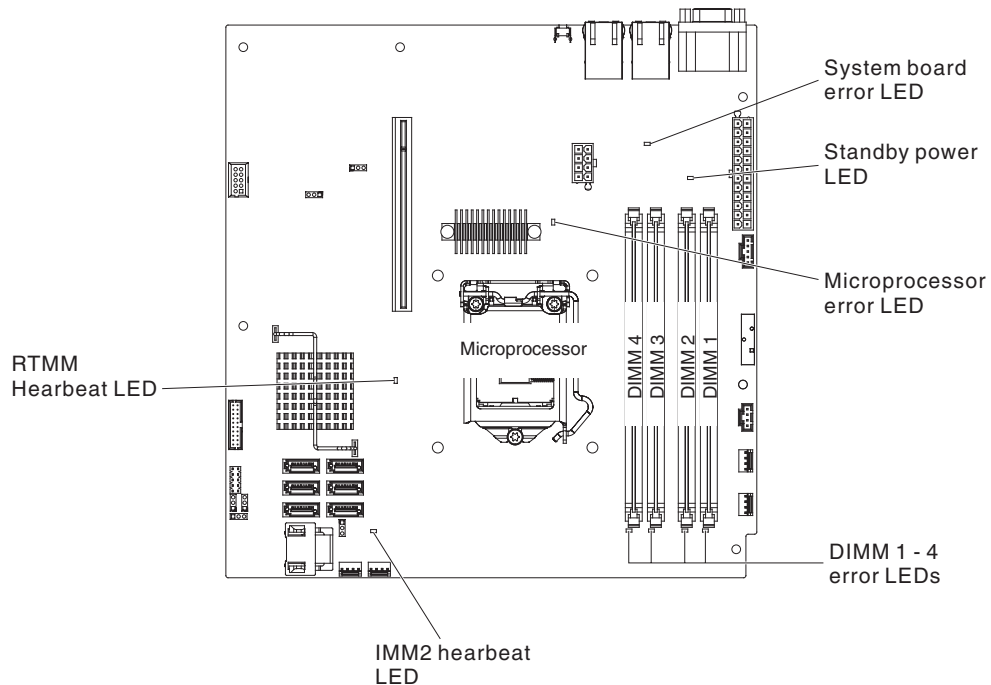

Note: When you disconnect the power source from the server, you lose the ability to view the LEDs because the LEDs are not lit when the power source is removed. Before you disconnect the power source, make a note of which LEDs are lit, including the LEDs that are lit on the operation information panel and LEDs inside the server on the system board.

Table 3. System-board LEDs

LED	Description
Standby power LED	When this LED is lit, it indicates that the server is connected to ac power.
DIMM error LEDs	A memory DIMM has failed or is incorrectly installed.
Microprocessor error LED	Microprocessor has failed, is missing, or has been incorrectly installed.
System-board error LED	System-board CPU VRD and/or power voltage regulators have failed.
IMM2 heartbeat LED	Indicates the status of the boot process of the IMM2. When the server is connected to power this LED flashes quickly to indicate that the IMM2 code is loading. When the loading is complete, the LED stops flashing briefly and then flashes slowly to indicate that the IMM2 is fully operational and you can press the power-control button to start the server.
RTMM heartbeat LED	power-on and power-off sequencing.

PCI riser-card assembly connectors

The following illustration shows the locations of the slots on the PCI riser-card assembly.

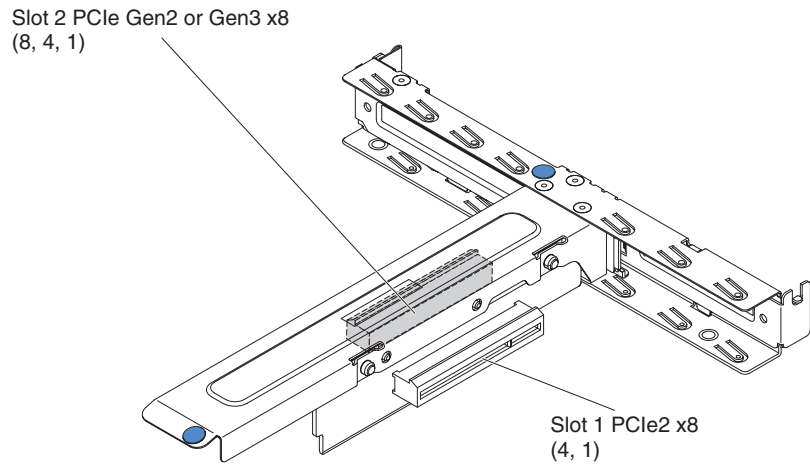

Installation guidelines

Attention: Static electricity that is released to internal server components when the server is powered-on might cause the system to halt, which might result in the loss of data. To avoid this potential problem, always use an electrostatic-discharge wrist strap or other grounding system when removing or installing a hot-swap device.

Before you install optional devices, read the following information:

- Read the safety information that begins on page “Safety” on page vii and the guidelines in “Working inside the server with the power on” on page 26, and “Handling static-sensitive devices” on page 27. This information will help you work safely.
- Make sure that the devices that you are installing are supported. For a list of supported optional devices for the server, see <http://www.ibm.com/systems/info/x86servers/serverproven/compat/us/>.
- When you install your new server, take the opportunity to download and apply the most recent firmware updates. This step will help to ensure that any known issues are addressed and that your server is ready to function at maximum levels of performance. To download firmware updates for your server, go to <http://www.ibm.com/systems/support/> or <http://www-933.ibm.com/support/fixcentral/>.
- Observe good housekeeping in the area where you are working. Place removed covers and other parts in a safe place.
- If you must start the server while the server cover is removed, make sure that no one is near the server and that no tools or other objects have been left inside the server.
- Blue on a component indicates touch points, where you can grip the component to remove it from or install it in the server, open or close a latch, and so on.
- Orange on a component or an orange label on or near a component indicates that the component can be hot-swapped, which means that if the server and operating system support hot-swap capability, you can remove or install the component while the server is running. Orange can also indicate touch points on

hot-swap components. See the instructions for removing or installing a specific hot-swap component for any additional procedures that you might have to perform before you remove or install the component.

- Do not attempt to lift an object that you think is too heavy for you. If you have to lift a heavy object, observe the following precautions:
 - Make sure that you can stand safely without slipping.
 - Distribute the weight of the object equally between your feet.
 - Use a slow lifting force. Never move suddenly or twist when you lift a heavy object.
 - To avoid straining the muscles in your back, lift by standing or by pushing up with your leg muscles.
- Make sure that you have an adequate number of properly grounded electrical outlets for the server, monitor, and other devices.
- Back up all important data before you make changes to disk drives.
- Have a small flat-blade screwdriver, a small Phillips screwdriver, and a T8 torx screwdriver available.
- You do not have to turn off the server to install or replace hot-swap power supplies, hot-swap hard disk drives, or hot-plug Universal Serial Bus (USB) devices. However, you must turn off the server before you perform any steps that involve removing or installing adapter cables and you must disconnect the power source from the server before you perform any steps that involve removing or installing a riser card.
- When you are finished working on the server, reinstall all safety shields, guards, labels, and ground wires.
- For a list of supported optional devices for the server, see <http://www.ibm.com/servers/eserver/serverproven/compat/us/>.

System reliability guidelines

To help ensure proper system cooling and system reliability, make sure that the following requirements are met:

- Each of the drive bays has a drive or a filler panel and electromagnetic compatibility (EMC) shield installed in it.
- If the server has redundant power, each of the power-supply bays has a power supply installed in it.
- There is adequate space around the server to allow the server cooling system to work properly. Leave approximately 50 mm (2.0 in.) of open space around the front and rear of the server. Do not place objects in front of the fans. For proper cooling and airflow, replace the server cover before you turn on the server.
- You have followed the cabling instructions that come with optional adapters.
- You have replaced a failed fan as soon as possible.
- You have replaced a hot-swap drive within 2 minutes of removal.
- You do not operate the server without the air baffle installed. Operating the server without the air baffle might cause the microprocessor to overheat.

Working inside the server with the power on

Attention: Static electricity that is released to internal server components when the server is powered on might cause the server to halt, which might result in the loss of data. To avoid this potential problem, always use an electrostatic-discharge wrist strap or other grounding system when you work inside the server with the power on.

The server supports hot-plug, hot-add, and hot-swap devices and is designed to operate safely while it is turned on and the server cover is removed. Follow these guidelines when you work inside a server that is turned on:

- Avoid wearing loose-fitting clothing on your forearms. Button long-sleeved shirts before working inside the server; do not wear cuff links while you are working inside the server.
- Do not allow your necktie or scarf to hang inside the server.
- Remove jewelry, such as bracelets, necklaces, rings, and loose-fitting wrist watches.
- Remove items from your shirt pocket, such as pens and pencils, that could fall into the server as you lean over it.
- Avoid dropping any metallic objects, such as paper clips, hairpins, and screws, into the server.

Handling static-sensitive devices

Attention: Static electricity can damage the server and other electronic devices. To avoid damage, keep static-sensitive devices in their static-protective packages until you are ready to install them.

To reduce the possibility of damage from electrostatic discharge, observe the following precautions:

- Limit your movement. Movement can cause static electricity to build up around you.
- The use of a grounding system is recommended. For example, wear an electrostatic-discharge wrist strap, if one is available. Always use an electrostatic-discharge wrist strap or other grounding system when working inside the server with the power on.
- Handle the device carefully, holding it by its edges or its frame.
- Do not touch solder joints, pins, or exposed circuitry.
- Do not leave the device where others can handle and damage it.
- While the device is still in its static-protective package, touch it to an unpainted metal surface on the outside of the server for at least 2 seconds. This drains static electricity from the package and from your body.
- Remove the device from its package and install it directly into the server without setting down the device. If it is necessary to set down the device, put it back into its static-protective package. Do not place the device on the server cover or on a metal surface.
- Take additional care when handling devices during cold weather. Heating reduces indoor humidity and increases static electricity.

Removing the server top cover

Important: Before you install optional hardware, make sure that the server is working correctly. Start the server, and make sure that the operating system starts, if an operating system is installed, or that a 19990305 error code is displayed, indicating that an operating system was not found but the server is otherwise working correctly. If the server is not working correctly, see the *Problem Determination and Service Guide* for diagnostic information.

To remove the server top cover, complete the following steps:

1. Read the safety information that begins on page “Safety” on page vii and “Installation guidelines” on page 25.

2. Turn off the server and peripheral devices and disconnect the power cords and all external cables, if necessary.

Note: When you disconnect the power source from the server, you lose the ability to view the LEDs because the LEDs are not lit when the power source is removed. Before you disconnect the power source, make a note of which LEDs are lit, including the LEDs that are lit on the front panel, on the rear panel, and LEDs inside the server on the system board; then, see the *Problem Determination and Service Guide* for information about how to solve the problem.

3. If the server has been installed in a rack, loosen the two thumbscrews on the front of the server and remove the server out of the rack enclosure; then, place it on a flat, static-protective surface.
4. Press down firmly on the blue tab on the top of the cover (on the right side near the front of the server) and slide the cover toward the rear of the server until the cover has disengaged from the chassis.

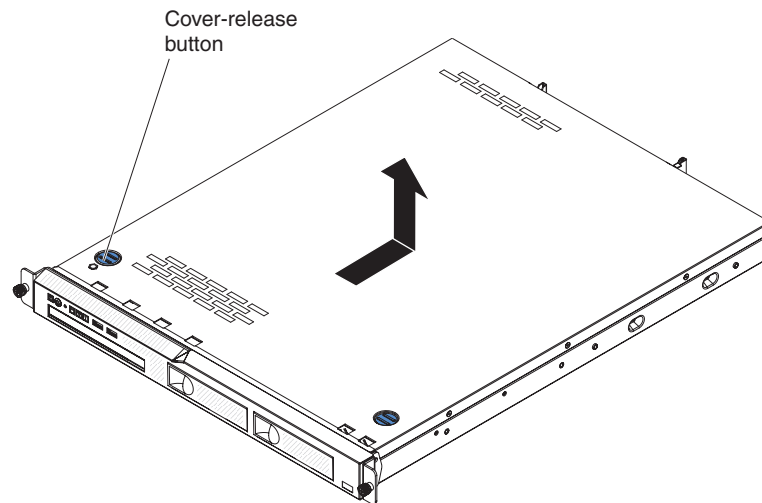

5. Lift the cover off the server and set it aside.

Attention: For proper cooling and airflow, replace the server top cover before you turn on the server.

Removing the air baffle

To remove the air baffle, complete the following steps:

1. Read the safety information that begins on page “Safety” on page vii and “Installation guidelines” on page 25.
2. Turn off the server and peripheral devices and disconnect the power cords and all external cables, if necessary.
3. Remove the server top cover (see “Removing the server top cover” on page 27).
4. Grasp the air baffle; then, lift it up out of the server and set it aside.

Attention: For proper cooling and airflow, replace the air baffle before you turn on the server. Operating the server with an air baffle removed might damage server components.

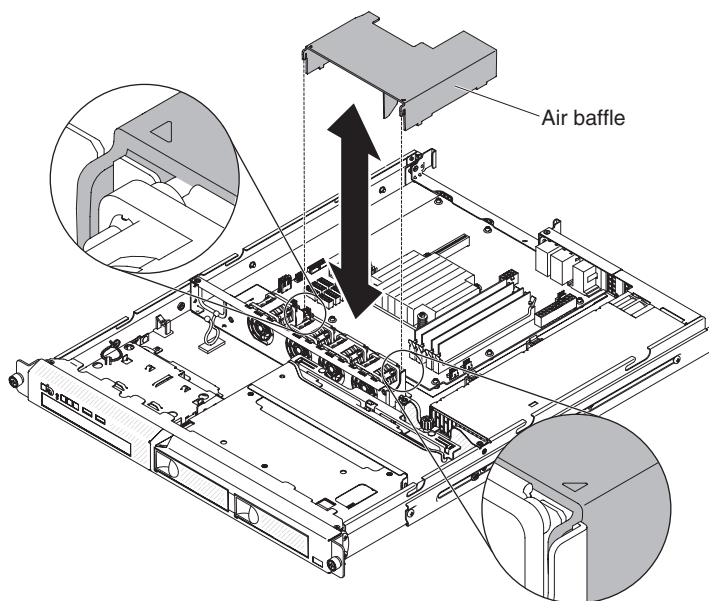

Removing the PCI riser-card assembly

To remove the PCI riser-card assembly, complete the following steps:

1. Read the safety information that begins on page “Safety” on page vii and the “Installation guidelines” on page 25.
2. Turn off the server and peripheral devices and disconnect the power cords and all external cables.

Note: When you disconnect the power source from the server, you lose the ability to view the LEDs because the LEDs are not lit when the power source is removed. Before you disconnect the power source, make a note of which LEDs are lit; then, see the *Problem Determination and Service Guide* for information about how to solve the problem.

3. Remove the server top cover (see “Removing the server top cover” on page 27).
4. If an adapter is installed in the PCI riser-card assembly, disconnect any cables that are connected to the adapter.
5. Grasp the front and rear of the PCI riser-card assembly and lift it out of the PCI riser-card slot on the system board.

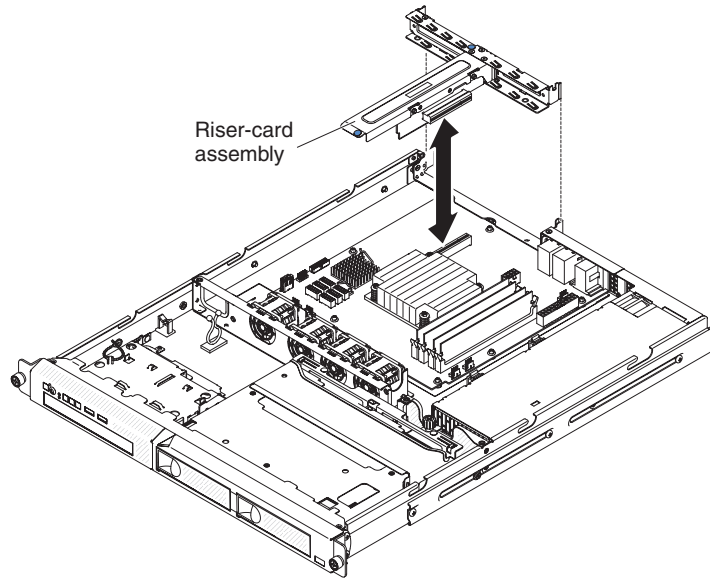

6. Remove the adapter, if one is present, from the PCI riser-card assembly.
7. Set the adapter and PCI riser-card assembly aside.

Memory module

The following notes describe the types of dual inline memory modules (DIMMs) that the server supports and other information that you must consider when you install DIMMs (see “System-board internal connectors” on page 20 for the location of the DIMM connectors):

- To confirm that the server supports the DIMM that you are installing, see <http://www.ibm.com/systems/info/x86servers/serverproven/compat/us/>.
- The server supports only industry-standard double-data-rate 3 (DDR3), 1333 MHz, PC3-10600 (single-rank or dual-rank), unbuffered, synchronous dynamic random-access memory (SDRAM) dual inline memory modules (DIMMs) with error correcting code (ECC).
- The server supports a maximum of four single-rank or dual-rank unbuffered DIMMs.
- The maximum operating speed of the server is determined by the slowest DIMM in the server.
- If you install a pair of DIMMs in DIMM connectors 1 and 3, the size and speed of the DIMMs that you install in DIMM connectors 1 and 3 must match each other. However, they do not have to be the same size and speed as the DIMMs that are installed in DIMM connectors 2 and 4.
- You can use compatible DIMMs from various manufacturers in the same pair.
- When you install or remove DIMMs, the server configuration information changes. When you restart the server, the system displays a message that indicates that the memory configuration has changed.
- The specifications of a DDR3 DIMM are on a label on the DIMM, in the following format.

ggg eRxff-PC3-wwwwwm-aa-bb-cc

where:

ggg is the total capacity of the DIMM (for example, 1GB, 2GB, or 4GB)

e is the number of ranks

1 = single-rank
 2 = dual-rank
 4 = quad-rank
ff is the device organization (bit width)
 4 = x4 organization (4 DQ lines per SDRAM)
 8 = x8 organization
 16 = x16 organization
wwwww is the DIMM bandwidth, in MBps
 8500 = 8.53 GBps (PC3-1066 SDRAMs, 8-byte primary data bus)
 10600 = 10.66 GBps (PC3-1333 SDRAMs, 8-byte primary data bus)
m is the DIMM type
 E = Unbuffered DIMM (UDIMM) with ECC (x72-bit module data bus)
 R = Registered DIMM (RDIMM)
 U = Unbuffered DIMM with no ECC (x64-bit primary data bus)
aa is the CAS latency, in clocks at maximum operating frequency
bb is the JEDEC SPD Revision Encoding and Additions level
cc is the reference design file for the design of the DIMM

Notes:

1. To determine the type of a DIMM, see the label on the DIMM. The information on the label is in the format *xxxxx nRxxx PC3-xxxxx-xx-xx-xxx*. The numeral in the sixth numerical position indicates whether the DIMM is single-rank (*n=1*) or dual-rank (*n=2*).
2. The amount of usable memory is reduced, depending on the system configuration. A certain amount of memory must be reserved for system resources. To view the total amount of installed memory and the amount of configured memory, run the Setup utility. For additional information, see Chapter 3, “Configuring the server,” on page 51.

The following sections provide additional information specific to unbuffered and registered DIMMs that you must consider.

Unbuffered DIMMs (UDIMMs)

The following notes provide information that you must consider when you install UDIMMs:

- The memory channels run at the lowest common frequency of the DIMMs installed.
- The UDIMM options that are available for the server are 1 GB, 2 GB, 4 GB, and 8 GB (when available) DIMMs.
- The server supports up to two single-rank or dual-rank UDIMMs per channel.
- The following table lists the supported UDIMM population.

Table 4. Supported UDIMM population per channel

DIMM connectors per channel	DIMMs installed in each channel	DIMM type	DIMM speed	Ranks per DIMM (any combination)
2	1	Unbuffered DDR3 ECC	1333	Single-rank, dual-rank
2	2	Unbuffered DDR3 ECC	1333	Single-rank, dual-rank

- The following table lists the maximum DIMM population using ranked UDIMMs.

Table 5. Maximum memory population using ranked UDIMMs (depending on your model)

Number of UDIMMs	DIMM type	Size	Total memory
4	Single-rank UDIMMs	1 GB	4 GB
4	Dual-rank UDIMMs	2 GB	8 GB
4	Dual-rank UDIMMs	4 GB	16 GB
4	Dual-rank UDIMMs	8 GB (when available)	32 GB

- The following table shows the UDIMM memory population rule to optimize the system performance.

Table 6. UDIMM population rule

DIMM connector 1	DIMM connector 2	DIMM connector 3	DIMM connector 4
Populated	Empty	Empty	Empty
Populated	Empty	Populated	Empty
Populated	Populated	Populated	Populated

Installing a memory module

The following illustration shows the location of the DIMM connectors on the system board.

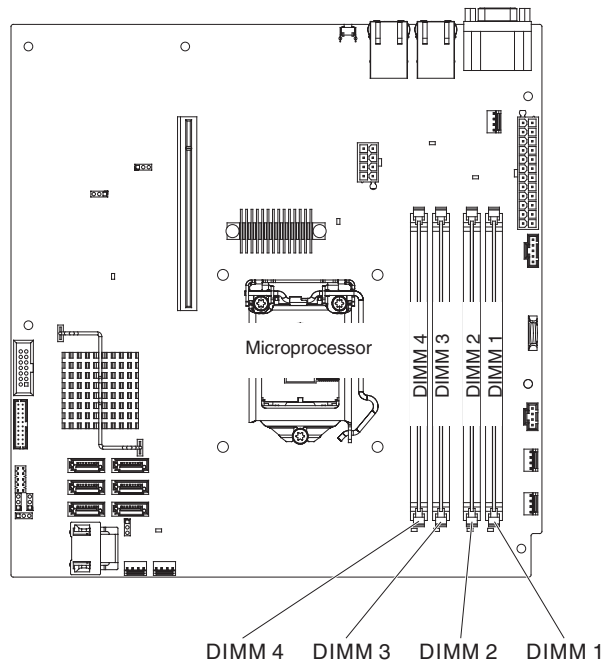

Attention: Static electricity that is released to internal server components when the server is powered on might cause the server to halt, which might result in the loss of data. To avoid this potential problem, always use an electrostatic-discharge wrist strap or other grounding system when you work inside the server with the power on.

To install a DIMM, complete the following steps:

1. Read the safety information that begins on page “Safety” on page vii and “Installation guidelines” on page 25.
2. Turn off the server and peripheral devices and disconnect the power cords and all external cables, if necessary.
3. Remove the server top cover (see “Removing the server top cover” on page 27).
4. Remove the air baffle (see “Removing the air baffle” on page 28).
5. Locate the DIMM connectors on the system board. Determine the connectors into which you will install the DIMMs. Install the DIMMs in the sequence shown in the following table.

Table 7. DIMM installation sequence

Number of DIMMs	Installation sequence (connectors)
First pair of DIMMs	1, 3
Second pair of DIMMs	2, 4

6. Open the retaining clip on each end of the DIMM connector.
Attention: To avoid breaking the retaining clips or damaging the DIMM connectors, open and close the clips gently.

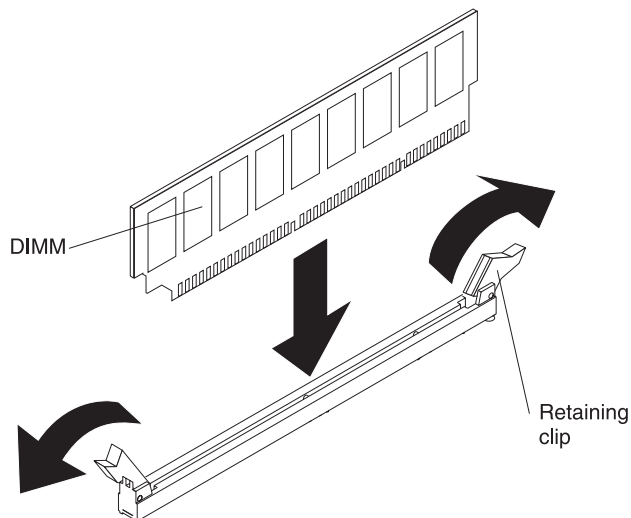

7. Touch the static-protective package that contains the DIMM to any unpainted metal surface on the outside of the server. Then, remove the DIMM from the package.
8. Turn the DIMM so that the DIMM keys align correctly with the connector.
9. Insert the DIMM into the connector by aligning the edges of the DIMM with the slots at the ends of the DIMM connector (see “System-board internal connectors” on page 20 for the locations of the DIMM connectors).
10. Firmly press the DIMM straight down into the connector by applying pressure on both ends of the DIMM simultaneously. The retaining clips snap into the locked position when the DIMM is firmly seated in the connector.

Note: If there is a gap between the DIMM and the retaining clips, the DIMM has not been correctly inserted; open the retaining clips, remove the DIMM, and then reinsert it.

If you have other devices to install or remove, do so now. Otherwise, go to “Completing the installation” on page 45.

Installing drives

The following notes describe the type of drives that the server supports and other information that you must consider when you install a drive. For a list of supported drives, see <http://www.ibm.com/servers/eserver/serverproven/compat/us/>.

- To confirm that the server supports the drive that you are installing, see <http://www.ibm.com/systems/info/x86servers/serverproven/compat/us/>.
- Locate the documentation that comes with the drive and follow those instructions in addition to the instructions in this chapter.
- Make sure that you have all the cables and other equipment that are specified in the documentation that comes with the drive.
- Select the bay in which you want to install the drive.
- The server supports one ultra-slim SATA optical drive.
- Check the instructions that come with the drive to determine whether you have to set any switches or jumpers on the drive. If you are installing a SAS or SATA hard disk drive, be sure to set the SAS or SATA ID for that device.
- The server supports four 2.5-inch simple-swap hard disk drives or two 3.5-inch simple-swap hard drive disk drives.
- The electromagnetic interference (EMI) integrity and cooling of the server are protected by having all bays and PCI and PCI Express slots covered or occupied. When you install a drive, PCI, or PCI Express adapter, save the EMC shield and filler panel from the bay or PCI adapter or PCI Express adapter slot cover in the event that you later remove the device.

Installing a simple-swap hard disk drive

Simple-swap hard disk drives are not hot-swappable. Disconnect all power from the server before you remove or install a simple-swap hard disk drive. To install a simple-swap hard disk drive, complete the following steps.

Notes:

1. If you have only one hard disk drive, install it in the left drive bay.
2. 3TB hard disk drives are not supported in OS 4690.
1. Read the safety information that begins on page “Safety” on page vii and “Installation guidelines” on page 25.
2. Make sure that the server top cover is in place and fully closed.
3. Turn off the server and peripheral devices, and disconnect the power cord and all external cables.
4. Remove the filler panel from the bay.
5. Install the hard disk drive:
 - To install a 3.5-inch simple-swap hard disk drive, pull the loops of the drive tray toward each other, and slide the drive into the server until the drive connects to the backplate. Release the loops of the drive tray.

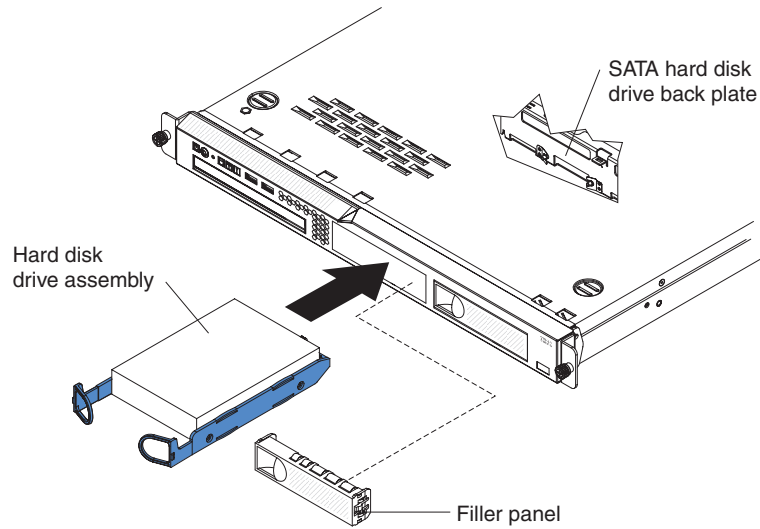

- To install a 2.5-inch simple-swap hard disk drive, slide the drive into the server until the drive clicks into the server and connects to the backplate.

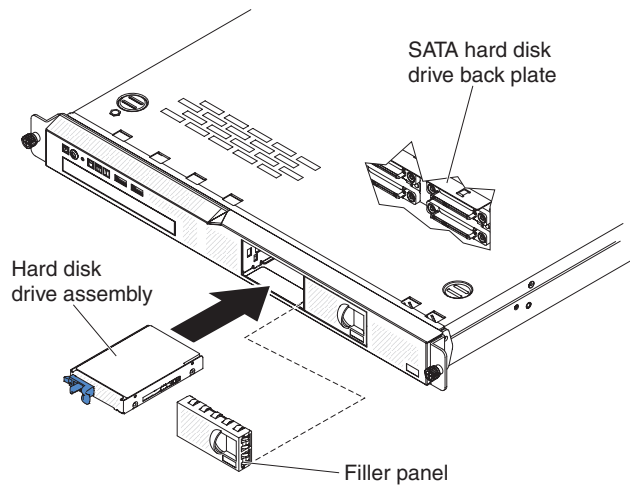

6. Insert the filler panel into the bay to cover the drive.

If you have other devices to install, do so now. Otherwise, go to “Completing the installation” on page 45.

Note: If a RAID controller or adapter is installed, you might have to reconfigure the disk arrays after you install hard disk drives. See your RAID controller or adapter documentation.

Installing a hot-swap hard disk drive

The 2.5-inch drive hot-swap server models support four SAS 2.5-inch hard disk drives.

Note: If you have only one hard disk drive, install it in the left or upper-left drive bay.

To install a hot-swap hard disk drive, complete the following steps.

Attention: To avoid damage to the hard disk drive connectors, make sure that the server top cover is in place and fully closed whenever you install or remove a hard disk drive.

1. Read the safety information that begins on page “Safety” on page vii and “Installation guidelines” on page 25.
2. Make sure that the server top cover is in place and fully closed.

Attention: To maintain proper system cooling, do not operate the server for more than 10 minutes without either a drive or filler panel installed in each bay.

3. Install the hard disk drive in the hot-swap bay:

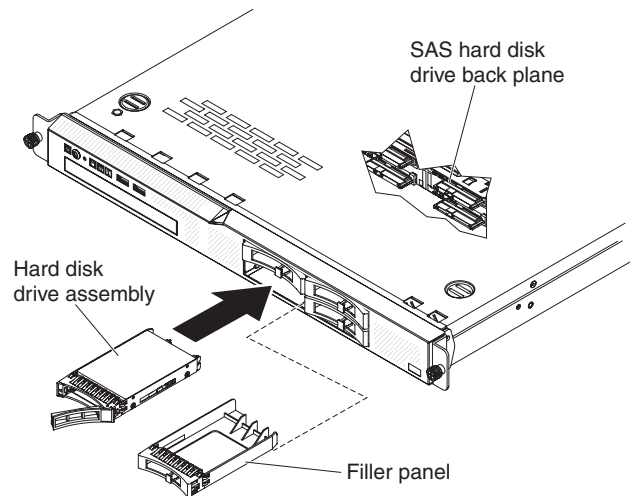

- a. Make sure that the drive tray handle is open (as shown in the illustration).
- b. Remove the filler panel from the bay.
- c. Align the drive assembly with the guide rails in the bay.
- d. Gently push the drive assembly into the bay until the drive stops.
- e. Push the tray handle to the closed (locked) position.
- f. Check the hard disk drive status LED to make sure that the hard disk drive is operating correctly. If the amber hard disk drive status LED for a drive is lit continuously, that drive is faulty and must be replaced. If the green hard disk drive activity LED is flashing, the drive is being accessed.

If you have other devices to install, do so now. Otherwise, go to “Completing the installation” on page 45.

Note: You might have to reconfigure the disk arrays after you install hard disk drives. See the RAID documentation on the IBM *ServeRAID Support* CD for information about RAID controllers.

Installing an optional DVD drive

Note: If you are installing a drive that contains a laser, observe the following safety precaution.

Statement 3:



CAUTION:

When laser products (such as CD-ROMs, DVD drives, fiber optic devices, or transmitters) are installed, note the following:

- Do not remove the covers. Removing the covers of the laser product could result in exposure to hazardous laser radiation. There are no serviceable parts inside the device.
- Use of controls or adjustments or performance of procedures other than those specified herein might result in hazardous radiation exposure.



DANGER

Some laser products contain an embedded Class 3A or Class 3B laser diode. Note the following.

Laser radiation when open. Do not stare into the beam, do not view directly with optical instruments, and avoid direct exposure to the beam.



Class 1 Laser Product
Laser Klasse 1
Laser Klass 1
Luokan 1 Laserlaite
Appareil À Laser de Classe 1

To install an optional DVD drive, complete the following steps:

1. Read the safety information that begins on page “Safety” on page vii and “Installation guidelines” on page 25.
2. Turn off the server and peripheral devices and disconnect the power cords and all external cables.

Note: When you disconnect the power source from the server, you lose the ability to view the LEDs because the LEDs are not lit when the power source is removed. Before you disconnect the power source, make a note of which LEDs are lit; then, see the *Problem Determination and Service Guide* for information about how to solve the problem.

3. Remove the server top cover (see “Removing the server top cover” on page 27).
4. Remove the DVD drive filler if it is installed. Pull the release tab (the rear of the drive-retention clip) toward the right side of the server to release the clip; then, while you pull the tab, push the DVD drive filler out of the bay. Save the DVD drive filler for future use.

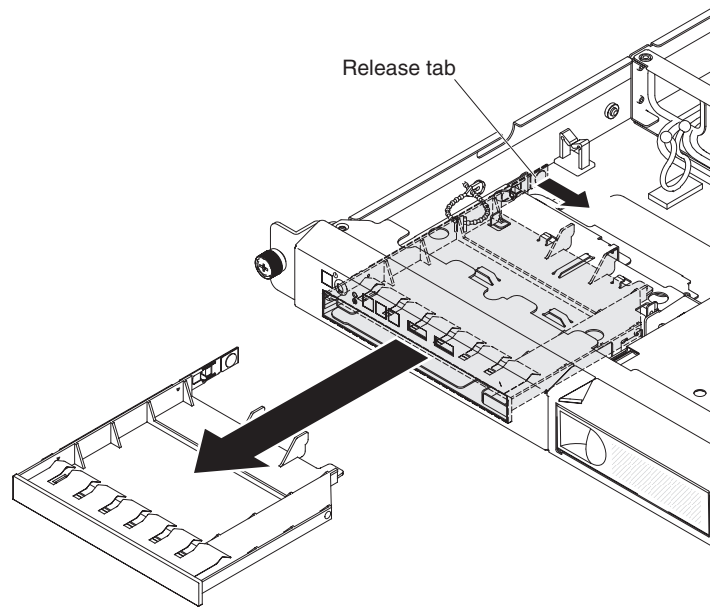

5. Touch the static-protective package that contains the new DVD drive to any unpainted metal surface on the server; then, remove the DVD drive from the package and place it on a static-protective surface.
6. Follow the instructions that come with the DVD drive to set any jumpers or switches.
7. Remove the retention clip from the DVD drive filler.
8. Attach the drive retention clip (that comes with the DVD drive filler) to the side of the new DVD drive.

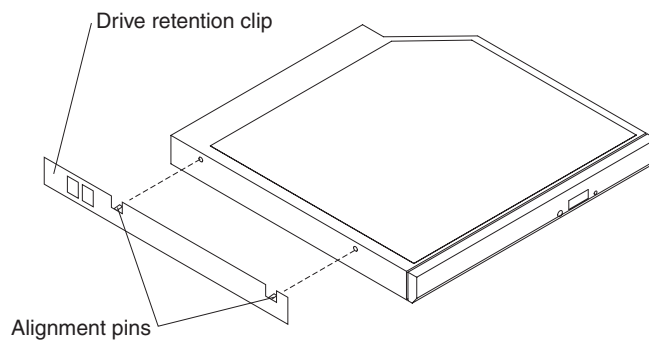

9. Align the drive in the drive bay and slide the drive into the DVD drive bay until the drive clicks into place.

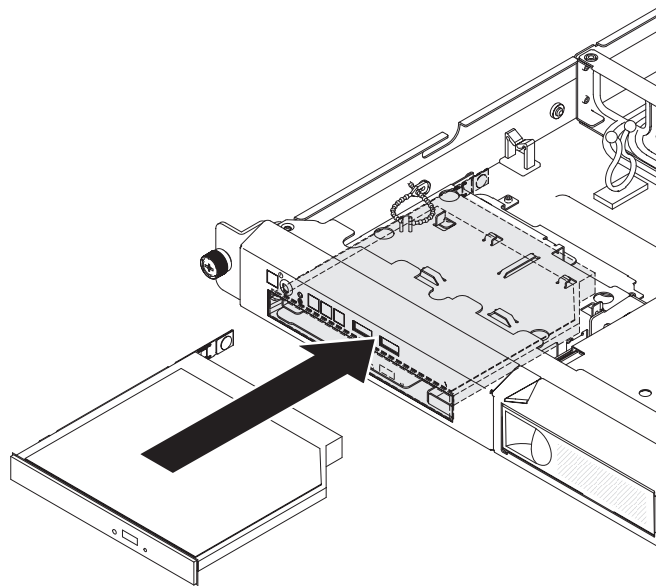

If you have other devices to install or remove, do so now. Otherwise, go to “Completing the installation” on page 45.

Installing an adapter

The following notes describe the types of adapters that the server supports and other information that you must consider when you install an adapter:

- To confirm that the server supports the adapter that you are installing, see <http://www.ibm.com/systems/info/x86servers/serverproven/compat/us/>.
- Locate the documentation that comes with the adapter and follow those instructions in addition to the instructions in this section. If you have to change switch settings or jumper settings on the adapter, follow the instructions that come with the adapter.
- The adapter slots are on the PCI riser-card assembly. You must first remove the PCI riser-card assembly to access the adapter slots.
- The expansion slots on the PCI riser-card assembly accommodate the various form factors of the non-hot-plug adapters as follows:
 - Expansion slot 1: Low-profile with 2U bracket (this slot is dedicated for ServeRAID-10iL v2 SAS/SATA controller)
 - Expansion slot 2: Full-height, half-length

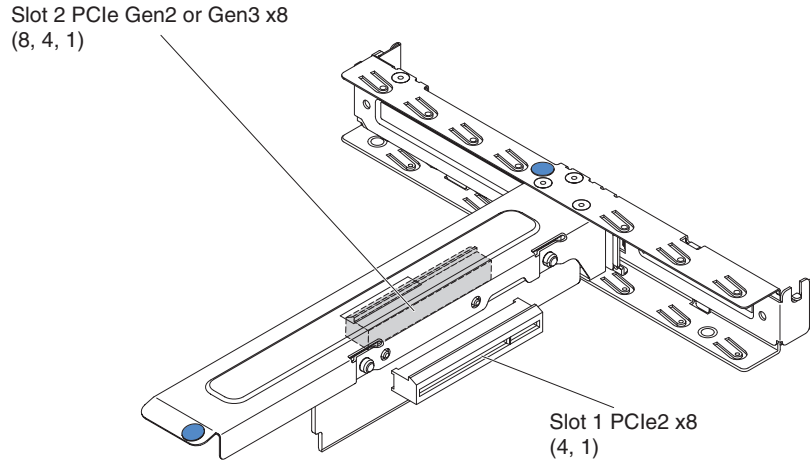

- The optional ServeRAID-BR10il controller v2 must be installed in expansion slot 1 on the PCI riser-card assembly.

Attention: Some cluster solutions require specific code levels or coordinated code updates. If the device is part of a cluster solution, verify that the latest level of code is supported for the cluster solution before you update the code.

To install an adapter, complete the following steps:

1. Read the safety information that begins on page “Safety” on page vii and the “Installation guidelines” on page 25.
2. Turn off the server and peripheral devices and disconnect the power cords and all external cables; then, remove the server top cover (see “Removing the server top cover” on page 27).
3. Remove the PCI riser-card assembly (see “Removing the PCI riser-card assembly” on page 29).
4. Touch the static-protective package that contains the adapter to any unpainted metal surface on the server. Then, remove the adapter from the static-protective package. Avoid touching the components and gold-edge connectors on the adapter.
5. Place the adapter, component side up, on a flat, static-protective surface and set any jumpers or switches as described by the adapter manufacturer, if necessary.
6. Follow the cabling instructions, if any come with the adapter. Route the adapter cables before you install the adapter.
7. Remove the expansion-slot cover from the PCI riser-card assembly and save for future use.
8. Align the connector on the adapter with the connector on the PCI riser-card assembly, then, insert the adapter into the PCI riser-card assembly. Press the edge of the connector *firmly* into the PCI riser-card assembly. Make sure that the adapter is securely installed in the PCI riser-card assembly.

Important: Make sure that the U-shaped opening in the metal adapter bracket engages the tab on the expansion-slot bracket.

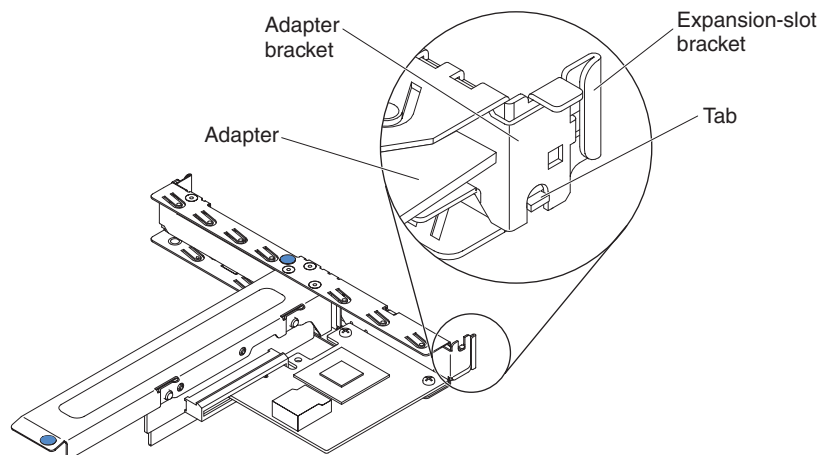

9. Reinstall the riser-card assembly in the server (see “Replacing the PCI riser-card assembly” on page 45).

Attention: When you install an adapter, make sure that the adapter is correctly seated in the PCI riser-card assembly and that the PCI riser-card assembly is securely seated in the riser-card connector on the system board before you turn on the server. An incorrectly seated adapter might cause damage to the system board, the PCI riser-card assembly, or the adapter.

If you have other devices to install or remove, do so now. Otherwise, go to “Completing the installation” on page 45.

Note: To support Windows 2011 SBS on Brocade adapters need to use at least 3.0.0.0 driver package or later version.

Installing a ServeRAID adapter

For configuration information, see the ServeRAID documentation at <http://www.ibm.com/systems/support/>.

Important: To ensure that any of your ServeRAID adapters function properly on UEFI-based servers, make sure that the adapter firmware and supporting device drivers are updated to at least 11.x.x-XXX.

To install a ServeRAID adapter, complete the following steps:

1. Read the safety information that begins on page “Safety” on page vii and “Installation guidelines” on page 25.
2. Turn off the server and peripheral devices and disconnect the power cords.

Note: When you disconnect the power source from the server, you lose the ability to view the LEDs because the LEDs are not lit when the power source is removed. Before you disconnect the power source, make a note of which LEDs are lit; then, see the *Problem Determination and Service Guide* for information about how to solve the problem.

3. Remove the server top cover (see “Removing the server top cover” on page 27).
4. Remove the PCI riser-card assembly (see “Removing the PCI riser-card assembly” on page 29).
5. Remove the expansion-slot cover on the slot that you intend to use and save for future use.

Attention: PCI expansion-slot covers must be installed on all vacant slots. This maintains the electronic emissions standards of the server and ensures proper ventilation of server components.

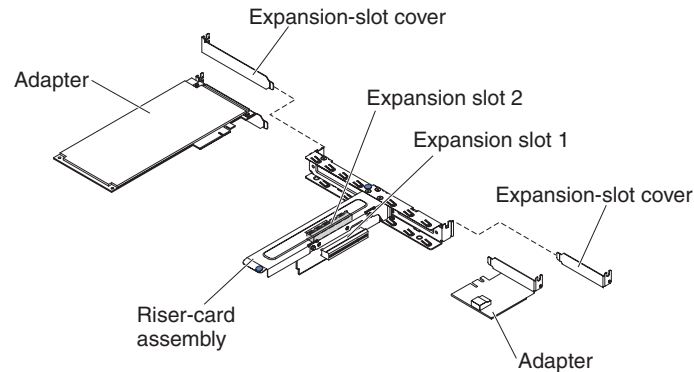

6. Touch the static-protective package that contains the new ServeRAID adapter to any unpainted surface on the outside of the server; then, grasp the adapter by the top edge or upper corners of the adapter and remove it from the package.
7. Take the signal cable that is attached to the drive backplane and connect it to the ServeRAID adapter.
 - If you install a ServeRAID adapter in slot 1 on the PCI riser-card assembly, route the signal cable from the drive backplane as shown in the following illustration.

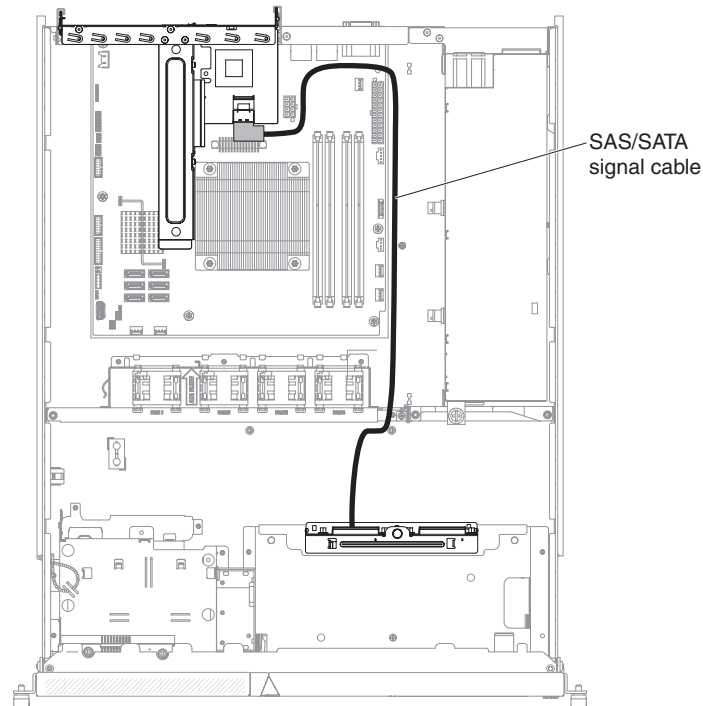

- If you install a ServeRAID-M1050 or ServeRAID-M5014 adapter in slot 2 on the PCI riser-card assembly, route the signal cable from the drive backplane through the fan cage hole on the left of fan 1 as shown in the following illustration. Connect the signal cable to **Port 0** on the ServeRAID adapter.

Notes:

- a. You must connect the signal cable to **Port 0** on a ServeRAID-M1050 or ServeRAID-M5014 adapter.
- b. Secure the cable on the system board with cable tie after routing.

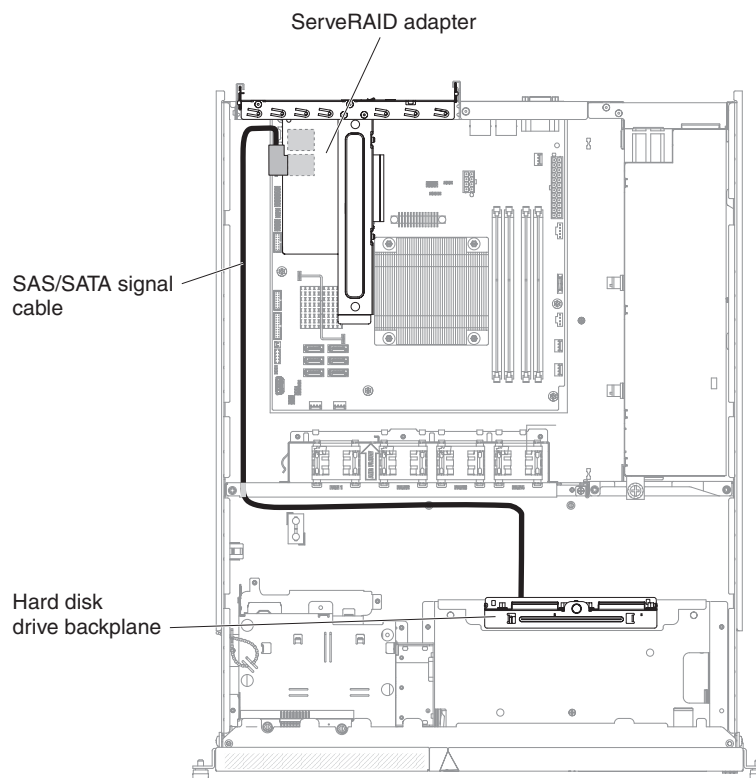

8. Align the ServeRAID adapter so that the keys align correctly with the connector on the PCI riser-card assembly.
9. Insert the ServeRAID adapter into the connector on the PCI riser-card assembly until it is firmly seated.
Attention: Incomplete insertion might cause damage to the server or the adapter.
10. Reinstall the riser-card assembly in the server (see “Replacing the PCI riser-card assembly” on page 45).
Attention: When you install an adapter, make sure that the adapter is correctly seated in the PCI riser-card assembly and that the PCI riser-card assembly is securely seated in the riser-card connector on the system board before you turn on the server. An incorrectly seated adapter might cause damage to the system board, the PCI riser-card assembly, or the adapter.

If you have other devices to install or remove, do so now. Otherwise, go to “Completing the installation” on page 45.

Note: When you restart the server, you are prompted to import the existing RAID configuration to the new ServeRAID adapter.

Installing a hot-swap power supply

The following notes describe the type of power supply that the server supports and other information that you must consider when you install a hot-swap power supply:

- To confirm that the server supports the power supply that you are installing, see <http://www.ibm.com/systems/info/x86servers/serverproven/compat/us/>.
- Depending on your server model, the server comes standard with one 460-watt hot-swap power supply. For redundancy support, you must install an additional hot-swap power supply, if one is not installed in your model.

To install an additional hot-swap power supply, complete the following steps:

1. Read the safety information that begins on page “Safety” on page vii and “Installation guidelines” on page 25.
2. Grasp the side clip and pull to remove the power-supply filler panel from the empty power-supply bay. Save the power-supply filler panel in case you remove the power supply at a later time.

Important: During normal operation, each power-supply bay must contain either a power supply or power-supply filler panel for proper cooling.

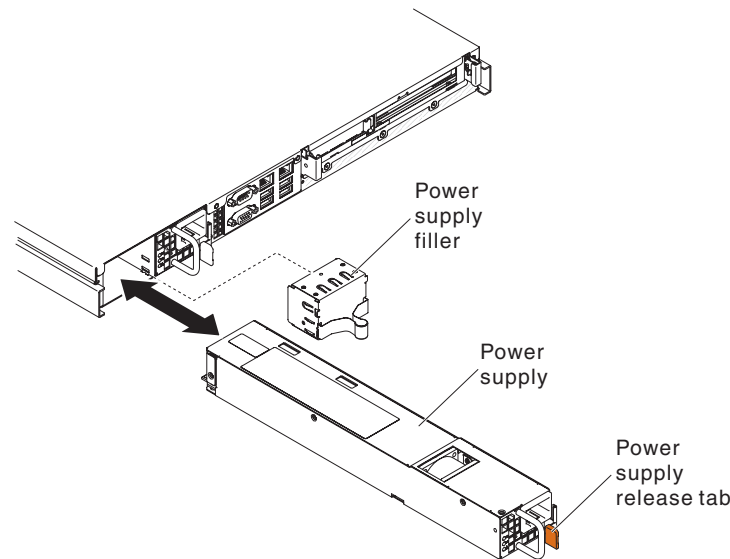

3. Slide the hot-swap power supply into the bay until the release latch clicks into place.
4. Connect one end of the power cord for the new power supply into the ac connector on the back of the power supply; then, connect the other end of the power cord into a properly grounded electrical outlet.
5. If the server is turned off, turn on the server.
6. Make sure that the ac power LED on the power supply is lit, indicating that the power supply is operating correctly. If the server is turned on, make sure that the dc power LED on the power supply is lit also.

Installing a USB embedded hypervisor flash device

To install a hypervisor flash device, complete the following steps:

1. Read the safety information that begins on page “Safety” on page vii and “Installation guidelines” on page 25.
2. Turn off the server and peripheral devices and disconnect the power cords.
3. Remove the server top cover (see “Removing the server top cover” on page 27).
4. Grasp the front and rear of the riser-card assembly and lift it out of the PCI riser-card slot on the system board.

5. Unlock the retention latch on the USB connector by squeezing the two retention clips toward each other.
6. Lift to open the retention latch.
7. Align the flash device with the USB connector on the system board and push it into the USB connector until it is firmly seated.
8. Press down on the retention latch to lock the flash device into the USB connector.

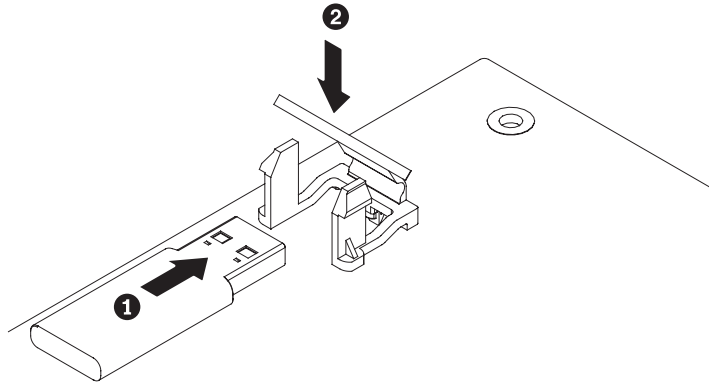

If you have other devices to install or remove, do so now. Otherwise, go to “Completing the installation.”

Completing the installation

To complete the installation, complete the following steps:

1. If you removed the PCI riser-card assembly, replace it (see “Replacing the PCI riser-card assembly”).
2. If you removed the air baffle, replace it (see “Replacing the air baffle” on page 46).
3. If you removed the server top cover, replace it (see “Replacing the server top cover” on page 47).
4. Install the server in the rack cabinet (see the *Rack Installation Instructions* that come with the server for instructions).
5. Reconnect the cables and power cords (see “Connecting the cables” on page 48).
6. Update the server configuration (see “Updating the server configuration” on page 49).
7. Slide the server back into the rack, if necessary.
8. (IBM Business Partners only) Complete the additional steps in “Instructions for IBM Business Partners” on page 17.

Replacing the PCI riser-card assembly

To install the PCI riser-card assembly, complete the following steps:

1. Read the safety information that begins on page “Safety” on page vii and “Installation guidelines” on page 25.
2. Install the adapters in the riser-card assembly (see “Installing an adapter” on page 39).
3. Reconnect any adapter cables that you disconnected when you removed the PCI riser-card assembly.

4. Carefully align the PCI riser-card assembly with the guides on the rear of the server and with the PCI riser-card connector on the system board; then, place your thumbs on locations marked by the blue dots and press down on the PCI riser-card assembly. Make sure that the riser-card assembly is fully seated in the connector on the system board.

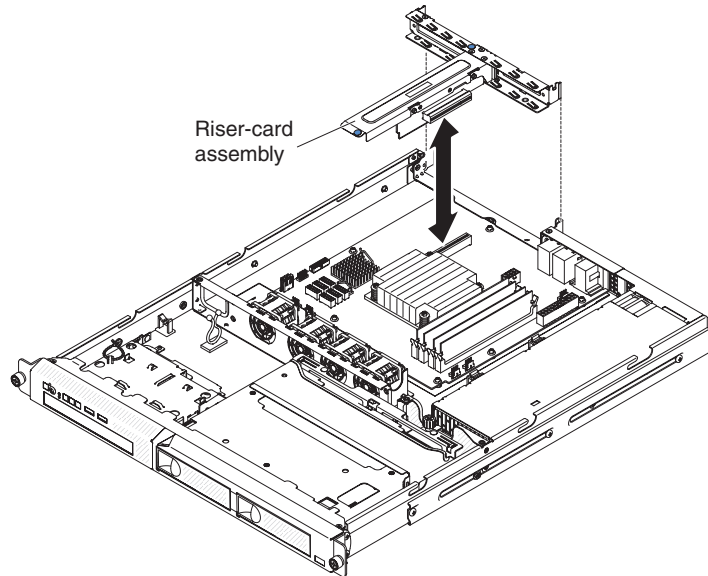

5. Install the server top cover (see “Replacing the server top cover” on page 47).
6. Slide the server into the rack.
7. Connect the cables and power cords.
8. Turn on all attached devices and the server.

Replacing the air baffle

To install the air baffle, complete the following steps:

1. Read the safety information that begins on page “Safety” on page vii and “Installation guidelines” on page 25.
2. Turn off the server and peripheral devices and disconnect the power cords and all external cables (see “Turning off the server” on page 14).
3. Make sure that all internal cables are correctly routed.
4. Align the air baffle with the slots on the chassis; then, lower the air baffle into the server.

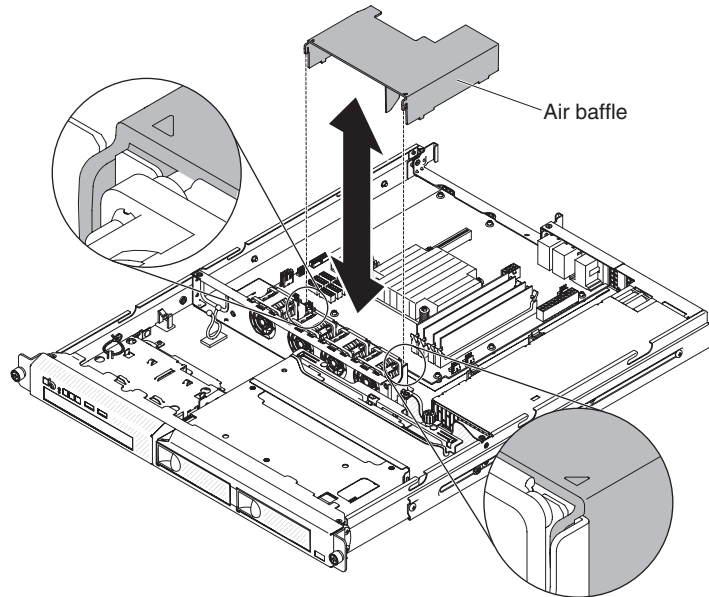

5. Install the server top cover (see “Replacing the server top cover”).
6. Reconnect the power cord and any cables that you removed.
7. Turn on the peripheral devices and the server.

Attention: For proper cooling and airflow, replace the air baffle before turning on the server. Operating the server with an air baffle removed might damage server components.

Replacing the server top cover

To replace the server top cover, complete the following steps:

1. Make sure that all cables, adapters, and other components are installed and seated correctly and that you have not left loose tools or parts inside the server. Also, make sure that all internal cables are correctly routed.

Important: Before you slide the cover forward, make sure that all the tabs on both the front, rear, and side of the cover engage the chassis correctly. If all the tabs do not engage the chassis correctly, it will be very difficult to remove the cover later.

2. Position the cover on top of the server so that approximately 13 mm (0.5 inch) extends from the rear.

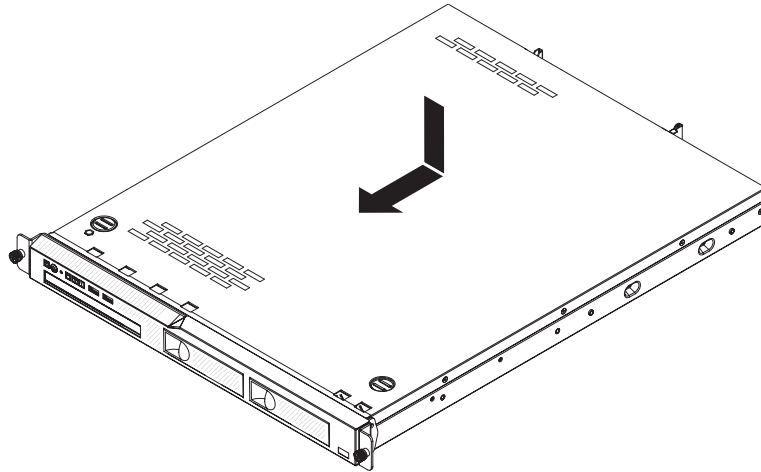

3. Slide the top cover toward the front of the server.
4. Make sure that the top cover correctly engages all the inset tabs on the server.
5. Install the server into the rack enclosure and tighten the two front thumbscrews to secure the server in the rack.
6. Reconnect the external cables and power cords.

Connecting the cables

The following illustration shows the locations of the input and output connectors on the front of the server.

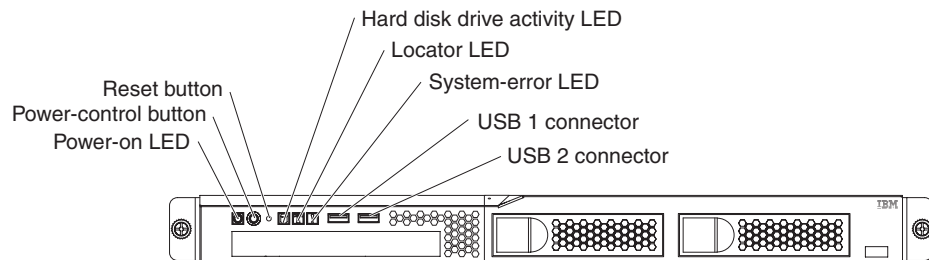
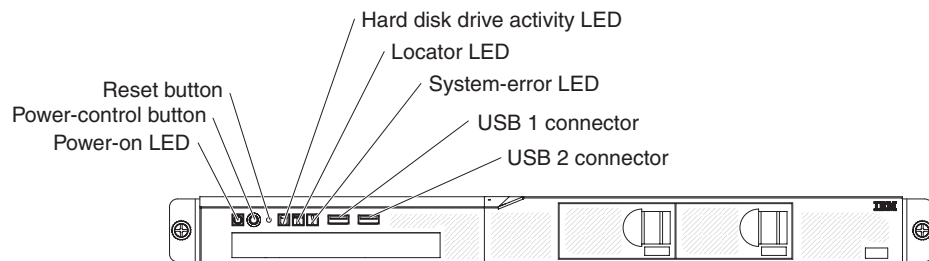

The following illustration shows the locations of the input and output connectors on the rear of the server.

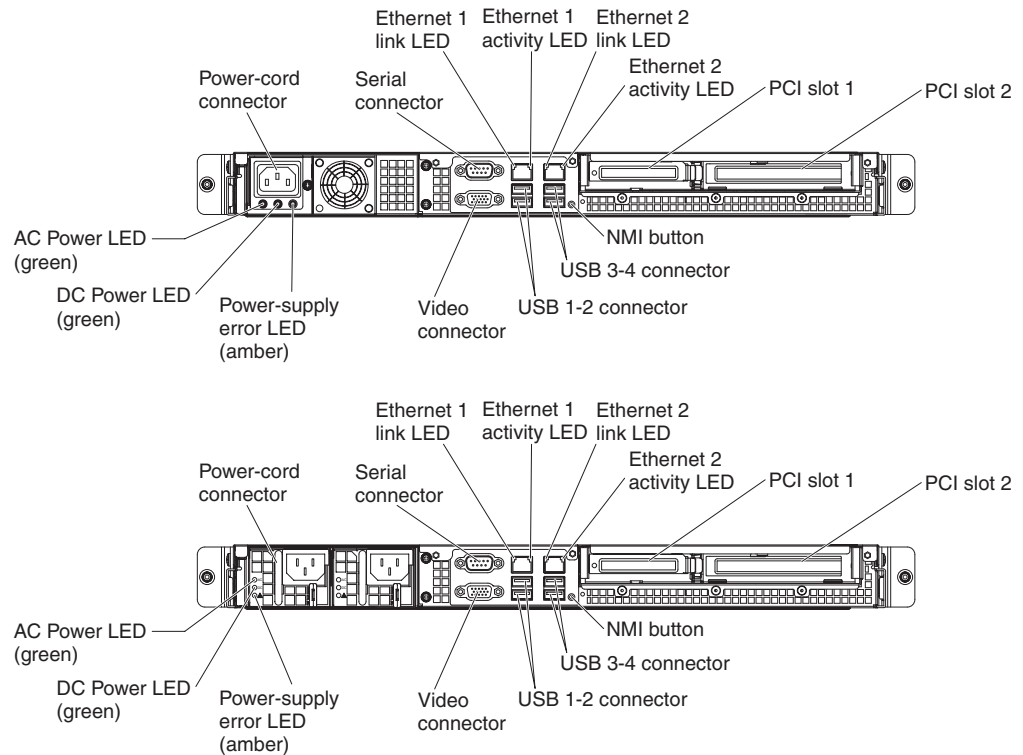

You must turn off the server before you connect or disconnect cables.

See the documentation that comes with any external devices for additional cabling instructions. It might be easier for you to route cables before you connect the devices to the server.

Cable identifiers are printed on the cables that come with the server and optional devices. Use these identifiers to connect the cables to the correct connectors.

Updating the server configuration

When you start the server for the first time after you add or remove a device, you might receive a message that the configuration has changed. The Setup utility starts automatically so that you can save the new configuration settings.

Some optional devices have device drivers that you must install. For information about installing device drivers, see the documentation that comes with each device.

If the server has an optional RAID adapter and you have installed or removed a hard disk drive, see the documentation that comes with the RAID adapter for information about reconfiguring the disk arrays.

For information about configuring the integrated Gigabit Ethernet controller, see “Configuring the Gigabit Ethernet controller” on page 65.

Chapter 3. Configuring the server

The following configuration programs come with the server:

- **Setup utility**

The Setup utility (formerly called the Configuration/Setup Utility program) is part of the basic input/output system firmware. Use it to change interrupt request (IRQ) settings, change the startup-device sequence, set the date and time, and set passwords. For information about using this program, see “Using the Setup utility” on page 52.

- **Boot Manager program**

The Boot Manager program is part of the server firmware. Use it to override the startup sequence that is set in the Setup utility and temporarily assign a device to be first in the startup sequence. For more information about using this program, see “Using the Boot Manager program” on page 57.

Note: OPROM configuration utility is only available for emulex 10G card.

- **IBM ServerGuide Setup and Installation CD**

The ServerGuide program provides software-setup tools and installation tools that are designed for the server. Use this CD during the installation of the server to configure basic hardware features, such as an integrated SAS/SATA controller with RAID capabilities, and to simplify the installation of your operating system. For information about using this CD, see “Using the ServerGuide Setup and Installation CD” on page 57.

- **integrated management module II**

Use the integrated management module II (IMM2) for configuration, to update the firmware and sensor data record/field replaceable unit (SDR/FRU) data, and to remotely manage a system. For information about using the IMM2, see “Using the integrated management module II (IMM2)” on page 59.

- **Ethernet controller configuration**

For information about configuring the Ethernet controller, see “Configuring the Gigabit Ethernet controller” on page 65.

- **LSI Configuration Utility program**

Use the LSI Configuration Utility program to configure the integrated SAS/SATA controller with RAID capabilities and the devices that are attached to it. For information about using this program, see “Using the LSI Configuration Utility program” on page 66.

- **IBM Advanced Settings Utility (ASU) program**

Use this program as an alternative to the Setup utility for modifying UEFI settings and IMM2 settings. Use the ASU program online or out of band to modify UEFI settings from the command line without the need to restart the server to access the Setup utility. For more information about using this program, see “IBM Advanced Settings Utility program” on page 70.

- **IBM Systems Director**

IBM Systems Director is a platform-management foundation that streamlines the way you manage physical and virtual systems in a heterogeneous environment. By using industry standards, IBM Systems Director supports multiple operating systems and virtualization technologies for IBM and non-IBM x86 platforms. For more information, see the documentation on the *IBM Systems Director* DVD and “IBM Systems Director” on page 10. For information about obtaining the latest IBM Systems Director code, see “Updating IBM Systems Director” on page 70.

Using the Setup utility

Use the Setup utility to perform the following tasks:

- View configuration information
- View and change assignments for devices and I/O ports
- Set the date and time
- Set the startup characteristics of the server and the order of startup devices
- Set and change settings for advanced hardware features
- View, set, and change settings for power-management features
- View and clear error logs
- Resolve configuration conflicts

Starting the Setup utility

To start the Setup utility, complete the following steps:

1. Turn on the server.

Note: Approximately 1 to 3 minutes after the server is connected to ac power, the power-control button becomes active after the power-on LED flashes slowly.

2. When the prompt <F1> Setup is displayed, press F1. If you have set an administrator password, you must type the administrator password to access the full Setup utility menu. If you do not type the administrator password, a limited Setup utility menu is available.
3. Select settings to view or change.

Setup utility menu choices

The following choices are on the Setup utility main menu. Depending on the version of the firmware, some menu choices might differ slightly from these descriptions.

- **System Information**

Select this choice to view information about the server. When you make changes through other choices in the Setup utility, some of those changes are reflected in the system information; you cannot change settings directly in the system information. This choice is on the full Setup utility menu only.

- **System Summary**

Select this choice to view configuration information, including the ID, speed, and cache size of the microprocessors, machine type and model of the server, the serial number, the system UUID, and the amount of installed memory. When you make configuration changes through other options in the Setup utility, the changes are reflected in the system summary; you cannot change settings directly in the system summary.

- **Product Data**

Select this choice to view the system-board identifier, the revision level or issue date of the firmware, the integrated management module and diagnostics code, and the version and date.

This choice is on the full Setup utility menu only.

- **System Settings**

Select this choice to view or change the server component settings.

- **Adapters and UEFI Drivers**

Select this choice to view information about the UEFI 1.10 and UEFI 2.0 compliant adapters and drivers installed in the server.

– **Processors**

Select this choice to view or change the processor settings.

– **Memory**

Select this choice to view or change the memory settings.

– **Devices and I/O Ports**

Select this choice to view or change assignments for devices and input/output (I/O) ports. You can configure the serial ports, configure remote console redirection, enable or disable integrated Ethernet controllers. If you disable a device, it cannot be configured, and the operating system will not be able to detect it (this is equivalent to disconnecting the device).

– **Power**

Select this choice to set the operating mode if a power loss occurs.

– **Operating Modes**

Select this choice to view or change the operating profile (performance and power utilization).

– **Legacy Support**

Select this choice to view or set legacy support.

- **Force Legacy Video on Boot**

Select this choice to force INT video support, if the operating system does not support UEFI video output standards.

- **Rehook INT 19h**

Select this choice to enable or disable devices from taking control of the boot process. The default is **Disable**.

- **Legacy Thunk Support**

Select this choice to enable or disable UEFI to interact with PCI mass storage devices that are non-UEFI compliant.

– **Integrated Management Module**

Select this choice to view or change the settings for the integrated management module.

- **POST Watchdog Timer**

Select this choice to view or enable the POST watchdog timer.

- **POST Watchdog Timer Value**

Select this choice to view or set the POST loader watchdog timer value.

- **Reboot System on NMI**

Enable or disable restarting the system whenever a nonmaskable interrupt (NMI) occurs. **Disabled** is the default.

- **Commands on USB Interface Preference**

Select this choice to enable or disable the Ethernet over USB interface on IMM2.

- **Network Configuration**

Select this choice to view the system management network interface port, the IMM2 MAC address, the current IMM2 IP address, and host name; define the static IMM2 IP address, subnet mask, and gateway address, specify whether to use the static IP address or have DHCP assign the IMM2 IP address, save the network changes, and reset the IMM2.

- **Reset IMM2 to Defaults**

- Select this choice to view or reset IMM2 to the default settings.
 - **Reset IMM2**
 - Select this choice to reset IMM2.
 - **System Security**
 - Select this choice to view or configure security settings .
 - **Network**
 - Select this choice to view or configure the network device options, such as PXE and network devices.
 - **Date and Time**
 - Select this choice to set the date and time in the server, in 24-hour format (*hour:minute:second*).
 - This choice is on the full Setup utility menu only.
 - **Start Options**
 - Select this choice to view or boot to devices, including the startup sequence. The server starts from the first boot record it finds.
 - This choice is on the full Setup utility menu only.
 - **Boot Manager**
 - Select this choice to view, add, delete, or change the device boot priority, boot from a file, select a one-time boot, or reset the boot order to the default setting.
 - If the server has Wake on LAN hardware and software and the operating system supports Wake on LAN functions, you can specify a startup sequence for the Wake on LAN functions. For example, you can define a startup sequence that checks for a disc in the CD-RW/DVD drive, then checks the hard disk drive, and then checks a network adapter.
- Note:** OPRM configuration utility is only available for emulex 10G card.
- **System Event Logs**
 - Select this choice to enter the System Event Manager, where you can view the POST event log and system-event log.
 - The POST event log contains the three most recent error codes and messages that were generated during POST.
 - The system-event logs contain POST and system management interrupt (SMI) events and all events that are generated by the integrated management module that is embedded in the integrated management module.
 - Important:** If the system-error LED on the front of the server is lit but there are no other error indications, clear the system-event log. Also, after you complete a repair or correct an error, clear the system-event log to turn off the system-error LED on the front of the server.
 - **POST Event Viewer**
 - Select this choice to enter the POST event viewer to view the POST event log.
 - **System Event Log**
 - Select this choice to view the system-event log.
 - **Clear System Event Log**
 - Select this choice to clear the system-event log.
 - **User Security**
 - Select this choice to set or clear passwords. See “Passwords” on page 55 for more information.
 - This choice is on the full and limited Setup utility menu.

- **Set Power-on Password**
Select this choice to set the power-on password. See “Power-on password” on page 56 for more information.
- **Clear Power-on Password**
Select this choice to clear the power-on password. See “Power-on password” on page 56 for more information.
- **Set Administrator Password**
Select this choice to set an administrator password. An administrator password is intended to be used by a system administrator; it limits access to the full Setup utility menu. If an administrator password is set, the full Setup utility menu is available only if you type the administrator password at the password prompt. For more information, see “Administrator password” on page 57.
- **Clear Administrator Password**
Select this choice to clear an administrator password. For more information, see “Administrator password” on page 57.
- **Save Settings**
Select this choice to save the changes that you have made in the settings.
- **Restore Settings**
Select this choice to cancel the changes that you have made in the settings and restore the previous settings.
- **Load Default Settings**
Select this choice to cancel the changes that you have made in the settings and restore the factory settings.
- **Exit Setup**
Select this choice to exit from the Setup utility. If you have not saved the changes that you have made in the settings, you are asked whether you want to save the changes or exit without saving them.

Passwords

From the **User Security** menu choice, you can set, change, and delete a power-on password and an administrator password. The **User Security** choice is on the full Setup utility menu only.

If you set only a power-on password, you must type the power-on password to complete the system startup and to have access to the full Setup utility menu.

An administrator password is intended to be used by a system administrator; it limits access to the full Setup utility menu. If you set only an administrator password, you do not have to type a password to complete the system startup, but you must type the administrator password to access the Setup utility menu.

If you set a power-on password for a user and an administrator password for a system administrator, you can type either password to complete the system startup. A system administrator who types the administrator password has access to the full Setup utility menu; the system administrator can give the user authority to set, change, and delete the power-on password. A user who types the power-on password has access to only the limited Setup utility menu; the user can set, change, and delete the power-on password, if the system administrator has given the user that authority.

Power-on password

If a power-on password is set, when you turn on the server, the system startup will not be completed until you type the power-on password. You can use any combination of 6 - 20 printable ASCII characters for the password.

When a power-on password is set, you can enable the Unattended Start mode, in which the keyboard and mouse remain locked but the operating system can start. You can unlock the keyboard and mouse by typing the power-on password.

If you forget the power-on password, you can regain access to the server in any of the following ways:

- If an administrator password is set, type the administrator password at the password prompt. Start the Setup utility and reset the power-on password.
- Remove the battery from the server and then reinstall it. See the *Problem Determination and Service Guide* on the IBM System x Documentation CD for instructions for removing the battery.
- Change the position of the clear CMOS jumper on the system board to pins 2 and 3 to clear the power-on password. The jumper location is shown in the following illustration.

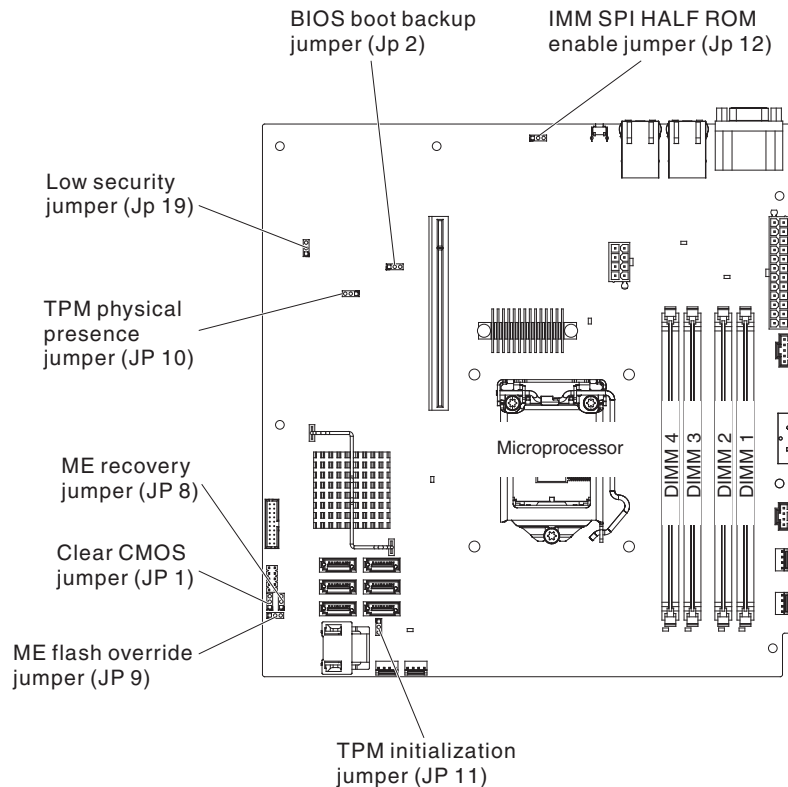

Attention: Before you change any switch settings or move any jumpers, turn off the server; then, disconnect all power cords and external cables. See the safety information that begins on page “Safety” on page vii. Do not change settings or move jumpers on any system-board jumper blocks that are not labelled in this document.

The clear CMOS jumper does not affect the administrator password.

Administrator password

If an administrator password is set, you must type the administrator password for access to the full Setup utility menu. You can use any combination of 6 - 20 printable ASCII characters for the password.

Attention: If you forget the administrator password, you cannot reset the password. You must replace the system board.

Using the Boot Manager program

The Boot Manager program is a built-in, menu-driven configuration utility program that you can use to temporarily redefine the first startup device without changing settings in the Setup utility.

To use the Boot Manager program, complete the following steps:

1. Turn off the server.
2. Restart the server.
3. When the prompt <F12> Select Boot Device is displayed, press F12. If a bootable USB mass storage device is installed, a submenu item (**USB Key/Disk**) is displayed.
4. Use the Up Arrow and Down Arrow keys to select an item from the **Boot Selection Menu** and press **Enter**.

Note: OPROM configuration utility is only available for emulex 10G card.

The next time the server starts, it returns to the startup sequence that is set in the Setup utility.

Starting the backup server firmware

The system board contains a backup copy area for the server firmware. This is a secondary copy of the server firmware that you update only during the process of updating the server firmware. If the primary copy of the server firmware becomes damaged, use this backup copy.

To force the server to start from the backup copy, turn off the server; then, place the JP2 jumper in the backup position (pins 2 and 3).

Use the backup copy of the server firmware until the primary copy is restored. After the primary copy is restored, turn off the server; then, move the JP2 jumper back to the primary position (pins 1 and 2).

Using the ServerGuide Setup and Installation CD

The *ServerGuide Setup and Installation CD* provides software setup tools and installation tools that are designed for your server. The ServerGuide program detects the server model and hardware options that are installed and uses that information during setup to configure the hardware. Use this CD during the initial installation of the server to simplify the operating-system installations by providing updated device drivers and, in some cases, installing them automatically. To download the CD, go to <http://www.ibm.com/systems/management/serverguide/sub.html> and click **IBM Service and Support Site**.

Note: Changes are made periodically to the IBM website. The actual procedure might vary slightly from what is described in this document.

To start the *ServerGuide Setup and Installation* CD, complete the following steps:

1. Insert the CD, and restart the server. If the CD does not start, see “ServerGuide Problems” in the *Problem Determination and Service Guide* on the *System x Documentation* CD.
2. Follow the instructions on the screen to:
 - a. Select your language.
 - b. Select your keyboard layout and country.
 - c. View the overview to learn about ServerGuide features.
 - d. View the readme file to review installation tips for your operating system and adapter.
 - e. Start the operating-system installation. You will need your operating-system CD.

The ServerGuide program has the following features:

- An easy-to-use interface
- Diskette-free setup, and configuration programs that are based on detected hardware
- ServeRAID Manager program, which configures your ServeRAID adapter
- Device drivers that are provided for your server model and detected hardware
- Operating-system partition size and file-system type that are selectable during setup

ServerGuide features

Features and functions can vary slightly with different versions of the ServerGuide program. To learn more about the version that you have, start the *ServerGuide Setup and Installation* CD and view the online overview. Not all features are supported on all server models.

The ServerGuide program requires a supported IBM server with an enabled startable (bootable) CD drive. In addition to the *ServerGuide Setup and Installation* CD, you must have your operating-system CD to install the operating system.

The ServerGuide program performs the following tasks:

- Sets system date and time
- Detects the RAID adapter or controller and runs the SAS/SATA RAID configuration program
- Checks the microcode (firmware) levels of a ServeRAID adapter and determines whether a later level is available from the CD
- Detects installed hardware options and provides updated device drivers for most adapters and devices
- Provides diskette-free installation for supported Windows operating systems
- Includes an online readme file with links to tips for your hardware and operating-system installation

Setup and configuration overview

When you use the *ServerGuide Setup and Installation* CD, you do not need setup diskettes. You can use the CD to configure any supported IBM server model. The setup program provides a list of tasks that are required to set up your server model. On a server with a ServeRAID adapter or SAS/SATA controller with RAID capabilities, you can run the SAS/SATA RAID configuration program to create logical drives.

Note: Features and functions can vary slightly with different versions of the ServerGuide program.

Typical operating-system installation

The ServerGuide program can reduce the time it takes to install an operating system. It provides the device drivers that are required for your hardware and for the operating system that you are installing. This section describes a typical ServerGuide operating-system installation.

Note: Features and functions can vary slightly with different versions of the ServerGuide program.

1. After you have completed the setup process, the operating-system installation program starts. (You will need your operating-system CD to complete the installation.)
2. The ServerGuide program stores information about the server model, hard disk drive controllers, and network adapters. Then, the program checks the CD for newer device drivers. This information is stored and then passed to the operating-system installation program.
3. The ServerGuide program presents operating-system partition options that are based on your operating-system selection and the installed hard disk drives.
4. The ServerGuide program prompts you to insert your operating-system CD and restart the server. At this point, the installation program for the operating system takes control to complete the installation.

Installing your operating system without using ServerGuide

If you have already configured the server hardware and you are not using the ServerGuide program to install your operating system, you can download operating-system installation instructions for the server from <http://www.ibm.com/supportportal/>.

Using the integrated management module II (IMM2)

The Integrated Management Module II (IMM2) is the second generation of the functions that were formerly provided by the Integrated Management Module (IMM). It combines service processor functions and the video controller in a single chip.

The IMM2 supports the following basic systems-management features:

- Environmental monitor with fan speed control for temperature, voltages, fan failure, and power supply failure. •
- DIMM error assistance. The Unified Extensible Firmware Interface (UEFI) disables a failing DIMM that is detected during POST, and the IMM2 lights the associated system error LED and the failing DIMM error LED.
- System event-log (SEL).
- ROM-based IMM2 firmware flash updates.
- Auto Boot Failure Recovery (ABR).
- Nonmaskable interrupt (NMI) detection and reporting.
- Automatic Server Restart (ASR) when POST is not complete or the operating system hangs and the operating system watchdog timer times-out. The IMM2 allows the administrator to generate a nonmaskable interrupt (NMI) by pressing an NMI button on the system board for an operating-system memory dump. ASR is supported by IPMI.

- Intelligent Platform Management Interface (IPMI) Specification V2.0 and Intelligent Platform Management Bus (IPMB) support.
- Invalid system configuration (CNFG) LED support.
- Serial over LAN (SOL).
- Power/reset control (power-on, hard and soft shutdown, hard and soft reset).
- Alerts (IPMI style PET traps).

Using IPMItool

IPMItool provides various tools that you can use to manage and configure an IPMI system. You can use IPMItool in-band to manage and configure the IMM2. For more information about IPMItool, or to download IPMItool, go to <http://sourceforge.net/>

Managing tools and utilities with IMM2 and IBM System x Server Firmware

This section describes the tools and utilities that are supported by IMM2 and IBM System x Server Firmware. The IBM tools that you use to manage the IMM2 in-band do not require you to install device drivers. However, if you choose to use certain tools such as IPMItool in-band, you must install the OpenIPMI drivers.

Updates and downloads for IBM systems-management tools and utilities are available on the IBM website. To check for updates to tools and utilities, complete the following steps.

Note: Changes are made periodically to the IBM website. Procedures for locating firmware and documentation might vary slightly from what is described in this document. See <http://www-947.ibm.com/support/entry/portal/docdisplay?brand=5000008&Indocid=TOOL-CENTER>.

Using IBM Advanced Settings Utility (ASU)

IBM Advanced Settings Utility (ASU) version 3.0.0 or later is required to manage IMM2. ASU is a tool that you can use to modify firmware settings from the command-line interface on multiple operating-system platforms. It also enables you to issue selected IMM2 setup commands. You can use ASU in-band to manage and configure the IMM2.

For more information about the ASU, go to <http://www-947.ibm.com/support/entry/portal/docdisplay?Indocid=TOOL-ASU>.

Using IBM Flash utilities and update utilities

A flash utility enables you to update hardware and server firmware and eliminates the need to manually install new firmware or firmware updates from a physical diskette or other medium. To find a flash utility, complete the following steps:

1. Go to <http://www.ibm.com/systems/support/>.
2. Under Product support, click System x.
3. Type flash utility in the search field and click Search.
4. Click the link to the applicable flash utility.

A flash utility enables you to update hardware and server firmware and eliminates the need to manually install new firmware or firmware updates from a physical diskette or other medium. To find a flash utility, complete the following steps:

1. Go to <http://www-947.ibm.com/support/entry/portal/docdisplay?lnodocid=SERV-XPRESS>.
2. Download IMM, uEFI, pDSA code from <http://www-933.ibm.com/support/fixcentral/>.
3. Follow IMM, uEFI, pDSA readme file for firmware update

Resetting the IMM2 with the Setup utility

To reset the IMM2 through the Setup utility, complete the following steps:

1. Turn on the server.

Note: Approximately 60 seconds after the server is connected to ac power, the power-control button becomes active.

2. When the prompt F1 Setup is displayed, press F1. If you have set both a power-on password and an administrator password, you must type the administrator password to access the full Setup utility menu.
3. From the Setup utility main menu, select **System Settings**.
4. On the next screen, select **Integrated Management Module**.
5. Select **Reset IMM**.

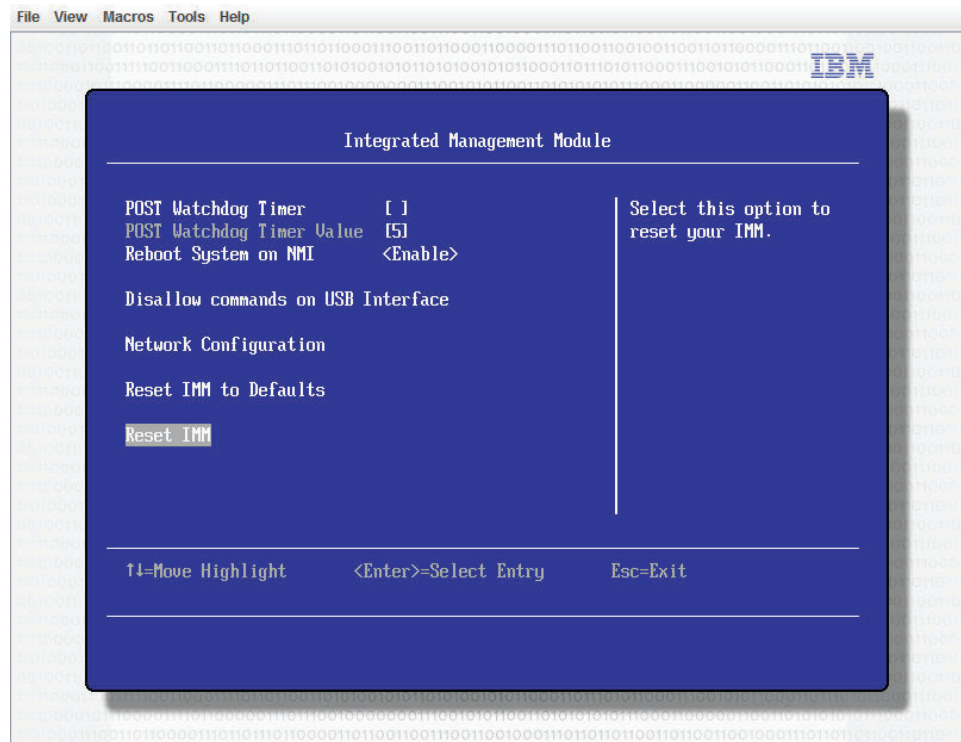

Note: After you reset the IMM2, this confirmation message is displayed immediately:

IMM2 reset command has been sent successfully!! Press ENTER to continue.

The IMM2 reset process is not yet complete. You must wait approximately 3 minutes for the IMM2 to reset before the IMM2 is

functional again. If you attempt to access sever firmware information while the server is resetting, Unknown is displayed in the fields, and the description is Error retrieving information from IMM2.

LAN over USB

A LAN over USB interface enables in-band communications to the IMM2; the IMM2 hardware on the system board presents an internal Ethernet NIC from the IMM2 to the operating system.

Typically, the IMM2 IP address for the LAN over USB interface is set to a static address of 169.254.95.118 with a subnet mask of 255.255.0.0. In the event of an IP address collision on the network, the IMM2 might obtain a different IP address in the 169.254.xxx.xxx range.

Because the IMM2 might obtain a random IP address for the LAN over USB interface, the ASU and firmware flash utilities, DSA, and the IBM Systems Director Agent use the Service Location Protocol (SLP) to discover the IMM2 IP address. These tools perform an SLP multicast discovery on the LAN over USB interface. When they receive a response from the IMM2, they obtain the attributes that contain the IP address that the IMM2 is using for the LAN over USB interface.

Potential conflicts with the LAN over USB interface

In some situations, the IMM2 LAN over USB interface can conflict with certain network configurations, applications, or both. For example, Open MPI attempts to use all of the available network interfaces on a server. Open MPI detects the IMM2 LAN over USB interface and attempts to use it to communicate with other systems in a clustered environment. The LAN over USB interface is an internal interface, so this interface does not work for external communications with other systems in the cluster.

Resolving conflicts with the IMM2 LAN over USB interface

There are several actions that resolve LAN over USB conflicts with network configurations and applications:

- For conflicts with Open MPI, configure the application so that it does not attempt to use the interface.
- Take the interface down (run `ifdown` under Linux).
- Remove the device driver (run `rmmod` under Linux).

Configuring the LAN over USB interface manually

For the IMM2 to use the LAN over USB interface, you might have to complete other configuration tasks if the automatic setup fails or if you prefer to set up the LAN over USB manually. The firmware update package or Advanced Settings Utility attempts to perform the setup automatically. For more information about LAN over USB configuration on different operating systems, see the IBM white paper [Transitioning to UEFI and IMM on the IBM website](#).

Installing device drivers

For the IMM2 to use the LAN over USB interface, you might have to install operating-system drivers. If the automatic setup fails or if you prefer to set up the LAN over USB manually, use one of the following procedures. For more information about LAN over USB configuration on different operating systems, see the IBM white paper [Transitioning to UEFI and IMM on the IBM website](#).

Installing the Windows IPMI device driver

The Microsoft IPMI device driver is not installed by default on Microsoft Windows Server 2003 R2 operating systems. To install the Microsoft IPMI device driver, complete the following steps:

1. From the Windows desktop, click **Start** → **Control Panel** → **Add or Remove Programs**.
2. Click **Add/Remove Windows Components**.
3. From the component list, select **Management and Monitoring Tools**, and then click **Details**.
4. Select **Hardware Management**.
5. Click **Next**. The installation wizard opens and guides you through the installation.

Note: The Windows installation CD might be required.

Installing the LAN over USB Windows device driver

When you install Windows, an unknown RNDIS device is shown in the Device Manager. You must install a Windows INF file that identifies this device and is required by Windows operating system to detect and use the LAN over USB functionality. The signed version of the INF is included in all of the Windows versions of the IMM2, UEFI, and DSA update packages. The file needs to be installed only once. To install the Windows INF file, complete the following steps:

1. Obtain the IMM2 update package.
2. Extract the `ibm_rndis_server_os.inf` and `device.cat` files from the firmware update package and copy them to the `\WINDOWS\inf` subdirectory.
3. **For Windows 2003:** Install the `ibm_rndis_server_os.inf` file by right-clicking on the file and selecting **Install**. This generates a PNF file of the same name in `\WINDOWS\inf`. **For Windows 2008:** Go to **Computer Management**, then **Device Manager** and locate the RNDIS Device. Select **Properties** → **Driver** → **Reinstall driver**. Point the server to the `\Windows\inf` directory, where it can locate the `ibm_rndis_server_os.inf` file and install the device.
4. Go to **Computer Management**, then **Device Manager**, right-click **Network adapters**, and select **Scan for hardware changes**. A message confirms that the Ethernet device is found and installed. The New Hardware Wizard starts automatically.
5. When you are prompted Can Windows connect to Windows Update to search for software?, click **No, not this time**. Click **Next** to continue.
6. When you are prompted What do you want the wizard to do?, click **Install from a list or specific location (Advanced)**. Click **Next** to continue.
7. When you are prompted Please choose your search and installation options, click **Don't search. I will choose the driver to install**. Click **Next** to continue.
8. When you are prompted Select a hardware type, and then click Next, click **Network adapters**. Click **Next** to continue.
9. When you are prompted Completing the Found New Hardware Wizard, click **Finish**.

Note: A new local area connection is displayed and might state This connection has limited or no connectivity. Ignore this message.

10. Go back to the Device Manager. Verify that **IBM USB Remote NDIS Network Device** appears under **Network Adapters**.

11. Open a command prompt, type `ipconfig`, and press Enter. The local area connection for the IBM USB RNDIS is displayed with an IP address in the range of 169.254.xxx.xxx with a subnet mask set to 255.255.0.0.

Installing the LAN over USB Linux device driver

Current versions of Linux, such as RHEL5 Update 2 and SLES10 Service Pack 2, support the LAN over USB interface by default. This interface is detected and displayed during the installation of these operating systems. When you configure the device, use a static IP address of 169.254.95.130 with a subnet mask of 255.255.0.0.

Note: Older Linux distributions might not detect the LAN over USB interface and might require manual configuration. For information about configuring LAN over USB on specific Linux distributions, see the IBM white paper *Transitioning to UEFI and IMM* on the IBM website.

The IMM2 LAN over USB interface requires that the `usbnet` and `cdc_ether` device drivers be loaded. If the device drivers have not been installed, use the `modprobe` command to install them. When these device drivers are installed, the IMM2 USB network interface is shown as a network device in the operating system. To discover the name that the operating system has assigned to the IMM2 USB network interface, type:

```
dmesg | grep -i cdc ether
```

Use the `ifconfig` command to configure the interface to have an IP address in the range 169.254.xxx.xxx. For example:

```
ifconfig IMM2_device_name 169.254.1.102 netmask 255.255.0.0
```

This interface is configured to have an IP address in the 169.254.xxx.xxx range each time that the operating system is started.

Using the embedded hypervisor

The VMware ESXi embedded hypervisor is available on server models that come with an installed USB embedded hypervisor flash device. The USB flash device installs in the USB connector on the system board (see “Installing a USB embedded hypervisor flash device” on page 44). Hypervisor is virtualization software that enables multiple operating systems to run on a host system at the same time. The USB flash device is required to activate the hypervisor functions.

To start using the embedded hypervisor functions, you must add the USB flash device to the boot order in the Setup utility.

To add the USB flash device to the boot order, complete the following steps:

1. Turn on the server.

Note: Approximately 1 to 3 minutes after the server is connected to ac power, the power-control button becomes active after the power-on LED flashes slowly.

2. When the prompt `<F1> Setup` is displayed, press F1.
3. From the Setup utility main menu, select **Boot Manager**.
4. Select **Add Boot Option**; then, select **Embedded Hypervisor**. Press Enter, and then select Esc.

5. Select **Change Boot Order** and then select **Commit Changes**; then, press Enter.
6. Select **Save Settings** and then select **Exit Setup**.

If the embedded hypervisor flash device image becomes corrupt, you can use the *VMware Recovery* CD that comes with the system to recover the flash device image. To recover the flash device image, complete the following steps:

1. Turn on the server.

Note: Approximately 1 to 3 minutes after the server is connected to ac power, the power-control button becomes active after the power-on LED flashes slowly.

2. Insert the VMware Recovery CD into the CD or DVD drive.
3. Follow the instructions on the screen.

For additional information and instructions, see the *VMware ESXi Server 3i Embedded Setup Guide* at http://www.vmware.com/pdf/vi3_35/esx_3i_e/r35/vi3_35_25_3i_setup.pdf

Enabling the Intel Gigabit Ethernet Utility program

The Intel Gigabit Ethernet Utility program is part of the server firmware. You can use it to configure the network as a startable device, and you can customize where the network startup option appears in the startup sequence. Enable and disable the Intel Gigabit Ethernet Utility program from the Setup utility.

Configuring the Gigabit Ethernet controller

The Ethernet controllers are integrated on the system board. They provide an interface for connecting to a 10 Mbps, 100 Mbps, or 1 Gbps network and provide full-duplex (FDX) capability, which enables simultaneous transmission and reception of data on the network. If the Ethernet ports in the server support auto-negotiation, the controllers detect the data-transfer rate (10BASE-T, 100BASE-TX, or 1000BASE-T) and duplex mode (full-duplex or half-duplex) of the network and automatically operate at that rate and mode.

You do not have to set any jumpers or configure the controllers. However, you must install a device driver to enable the operating system to address the controllers. To find updated information about configuring the controllers, go to <http://www.ibm.com/supportportal/>.

Enabling and configuring Serial over LAN (SOL)

Establish a Serial over LAN (SOL) connection to manage servers from a remote location. You can remotely view and change the BIOS settings, restart the server, identify the server, and perform other management functions. Any standard Telnet client application can access the SOL connection.

To enable and configure the server for SOL, you must update and configure the UEFI code; update and configure the integrated management module II (IMM2) firmware; update and configure the Ethernet controller firmware; and enable the operating system for an SOL connection.

UEFI update and configuration

To update and configure the UEFI code to enable SOL, complete the following steps:

1. Update the UEFI code:
 - a. Download the latest version of the UEFI code from <http://www.ibm.com/systems/support/>.
 - b. Update the UEFI code, following the instructions that come with the update file that you downloaded.
2. Update the IMM2 firmware:
 - a. Download the latest version of the IMM2 firmware from <http://www.ibm.com/systems/support/> or <http://www-933.ibm.com/support/fixcentral/>.
 - b. Update the IMM2 firmware, following the instructions that come with the update file that you downloaded.
3. Configure the UEFI settings:
 - a. When you are prompted to start the Configuration/Setup Utility program, restart the server and press F1.
 - b. Select **System Settings** → **Devices and I/O Ports**.
 - c. Select **Console Redirection Settings**; then, make sure that the values are set as follows:
 - **COM Port 1**: Enable
 - **Remote Console**: Enable
 - **Serial Port Sharing**: Enable
 - **Serial Port Access Mode**: Dedicated COM1 Settings
 - **Baud Rate**: 115200
 - **Data Bits**: 8
 - **Parity**: None Stop
 - **Bits**: 1
 - **Thermal Emulation**: ANSI
 - **Active After Boot**: Enable
 - **Flow Control**: Hardware
 - d. Press Esc twice to exit the **Devices and I/O Ports** section of the Configuration/Setup Utility program.
 - e. Select **Save Settings**; then, press Enter.
 - f. Press Enter to confirm.
 - g. Select **Exit Setup**; then, press Enter.
 - h. Make sure that Yes, exit the Setup Utility is selected; then, press Enter.

Using the LSI Configuration Utility program

Note: OPROM configuration utility is only available for emulex 10G card. Use the LSI Configuration Utility program to configure and manage redundant array of independent disks (RAID) arrays. Be sure to use this program as described in this document.

- Use the LSI Configuration Utility program to perform the following tasks:
 - Perform a low-level format on a hard disk drive
 - Create an array of hard disk drives with or without a hot-spare drive

- Set protocol parameters on hard disk drives

The integrated SAS/SATA controller with RAID capabilities supports RAID arrays. You can use the LSI Configuration Utility program to configure RAID 1 (IM), RAID 1E (IME), and RAID 0 (IS) for a single pair of attached devices. If you install the optional ServeRAID-MR10i SAS/SATA controller, it provides RAID levels 0, 1, and 10 support. If you install a different type of RAID adapter, follow the instructions in the documentation that comes with the adapter to view or change settings for attached devices.

In addition, you can download an LSI command-line configuration program from <http://www.ibm.com/systems/support/>.

When you are using the LSI Configuration Utility program to configure and manage arrays, consider the following information:

- The integrated SAS/SATA controller with RAID capabilities supports the following features:
 - Integrated Mirroring (IM) with hot-spare support (also known as RAID 1)
Use this option to create an integrated array of two disks plus up to two optional hot spares. All data on the primary disk can be migrated.
 - Integrated Mirroring Enhanced (IME) with hot-spare support (also known as RAID 1E)
Use this option to create an integrated mirror enhanced array of three to eight disks, including up to two optional hot spares. All data on the array disks will be deleted.
 - Integrated Striping (IS) (also known as RAID 0)
Use this option to create an integrated striping array of two to eight disks. All data on the array disks will be deleted.
- Hard disk drive capacities affect how you create arrays. The drives in an array can have different capacities, but the RAID controller treats them as if they all have the capacity of the smallest hard disk drive.
- If you use an integrated SAS/SATA controller with RAID capabilities to configure a RAID 1 (mirrored) array after you have installed the operating system, you will lose access to any data or applications that were previously stored on the secondary drive of the mirrored pair.
- If you install a different type of RAID controller, see the documentation that comes with the controller for information about viewing and changing settings for attached devices.

Starting the LSI Configuration Utility program

To start the LSI Configuration Utility program, complete the following steps:

1. Turn on the server.

Note: Approximately 1 to 3 minutes after the server is connected to ac power, the power-control button becomes active after the power-on LED flashes slowly.

2. When the prompt <F1 Setup> is displayed, press F1. If you have set an administrator password, you are prompted to type the password.
3. Select **System Settings** → **Adapters and UEFI drivers**.
4. Select **Please refresh this page on the first visit** and press Enter.

5. Select **LSI controller_driver_name Driver** and press Enter, where *controller_driver_name* is the name of the SAS/SATA controller driver. For the SAS/SATA controller driver name, see the documentation that comes with your controller.
6. To perform storage-management tasks, follow the procedures in the documentation that comes with the SAS/SATA controller.

When you have finished changing settings, press Esc to exit from the program; select **Save** to save the settings that you have changed.

Formatting a hard disk drive

Low-level formatting removes all data from the hard disk. If there is data on the disk that you want to save, back up the hard disk before you perform this procedure.

Note: Before you format a hard disk, make sure that the disk is not part of a mirrored pair.

To format a drive, complete the following steps:

1. From the list of adapters, select the controller (channel) for the drive that you want to format and press Enter.
2. Select **SAS Topology** and press Enter.
3. Select **Direct Attach Devices** and press Enter.
4. To highlight the drive that you want to format, use the Up Arrow and Down Arrow keys. To scroll left and right, use the Left Arrow and Right Arrow keys or the End key. Press Alt+D.
5. To start the low-level formatting operation, select **Format** and press Enter.

Creating a RAID array of hard disk drives

To create a RAID array of hard disk drives, complete the following steps:

1. From the list of adapters, select the controller (channel) for the drives that you want to mirror.
2. Select **RAID Properties**.
3. Select the type of array that you want to create.
4. Use the arrow keys to highlight the first drive in the pair; then, press the Minus (-) or Plus (+) key to change the mirror value to **Primary**.
5. Continue to select the next drive using the Minus (-) or Plus (+) key until you have selected all the drives for your array.
6. Press C to create the disk array.
7. Select **Apply changes and exit menu** to create the array.

Creating a software RAID array of hard disk drives

To create a software RAID array of hard disk drives, complete the following steps:

1. Turn on the server.

Note: Approximately 1 to 3 minutes after the server is connected to ac power, the power-control button becomes active after the power-on LED flashes slowly.

2. When the prompt <F1 Setup> is displayed, press F1. If you have set an administrator password, you are prompted to type the password.
3. Select **Devices and I/O Ports → Adapters and UEFI drivers**.

4. Save the setting and reboot the system.
5. Press F1 to boot the uEFI setup menu.
6. Select **Devices and I/O Ports → Adapters and UEFI drivers**.
7. Select **Storage**.
8. Select **LSI MegaRAID Controller Configuration Utility → Virtual Driver Management → Create Configuration**.
9. Select the type of array that you want to create.
10. Select the **Select Driver** and use space key to select all the drives for your array.
11. Select the **Apply Change** to create the array.
12. Press C to create the disk array.
13. When the prompt Configuration completed is displayed, select **OK** to continue.
14. After the system auto skip to the next screen, select **Save Configuration** .
15. When the prompt create RAID will cause data lost on the physical HDD is displayed, use space key to select **Confirm**.
16. Select **OK** to continue.
17. To initialize virtual disk, select **LSI MegaRAID Controller Configuration Utility → Virtual Driver Management → Select Virtual Driver Operation**.

Notes:

1. Software RAID is not supported in Redhat 6.1 UEFI mode.
2. You can create software RAID with Linux OS RAID. LSI software RAID is turned off in Linux OS by default.
3. Legacy OS installation is not supported when BBS boot is enabled on ServeRAID M5014.
4. Brocade adapters are supported in Windows 2011 SBS with 3.0.0.0 driver package or later version installed.

Disable a software RAID array of hard disk drives

To disable a software RAID array of hard disk drives, complete the following steps:

1. Turn on the server.

Note: Approximately 1 to 3 minutes after the server is connected to ac power, the power-control button becomes active after the power-on LED flashes slowly.

2. When the prompt <F1 Setup> is displayed, press F1. If you have set an administrator password, you are prompted to type the password.
3. Select **Devices and I/O Ports → Adapters and UEFI drivers**.
4. Save the setting and reboot the system.
5. Press F1 to boot the uEFI setup menu.
6. Select **Devices and I/O Ports → Configure SATA as**.
7. Select **IDE** or **AHCI**.
8. Save the setting and reboot the system.

IBM Advanced Settings Utility program

The IBM Advanced Settings Utility (ASU) program is an alternative to the Setup utility for modifying UEFI settings. Use the ASU program online or out of band to modify UEFI settings from the command line without the need to restart the system to access the Setup utility.

In addition, the ASU program provides limited settings for configuring the IPMI function in the IMM2 through the command-line interface.

Use the command-line interface to issue setup commands. You can save any of the settings as a file and run the file as a script. The ASU program supports scripting environments through a batch-processing mode.

For more information and to download the ASU program, go to <http://www.ibm.com/systems/support/>.

Updating IBM Systems Director

If you plan to use IBM Systems Director to manage the server, you must check for the latest applicable IBM Systems Director updates and interim fixes.

Note: Changes are made periodically to the IBM website. The actual procedure might vary slightly from what is described in this document.

To locate and install a newer version of IBM Systems Director, complete the following steps:

1. Check for the latest version of IBM Systems Director:
 - a. Go to <http://www.ibm.com/systems/management/director/downloads.html>.
 - b. If a newer version of IBM Systems Director than what comes with the server is shown in the drop-down list, follow the instructions on the web page to download the latest version.
2. Install the IBM Systems Director program.

If your management server is connected to the Internet, to locate and install updates and interim fixes, complete the following steps:

1. Make sure that you have run the Discovery and Inventory collection tasks.
2. On the Welcome page of the IBM Systems Director web interface, click **View updates**.
3. Click **Check for updates**. The available updates are displayed in a table.
4. Select the updates that you want to install, and click **Install** to start the installation wizard.

If your management server is not connected to the Internet, to locate and install updates and interim fixes, complete the following steps:

1. Make sure that you have run the Discovery and Inventory collection tasks.
2. On a system that is connected to the Internet, go to <http://www.ibm.com/eserver/support/fixes/fixcentral/>.
3. From the **Product family** list, select **IBM Systems Director**.
4. From the **Product** list, select **IBM Systems Director**.
5. From the **Installed version** list, select the latest version, and click **Continue**.
6. Download the available updates.

7. Copy the downloaded files to the management server.
8. On the management server, on the Welcome page of the IBM Systems Director web interface, click the **Manage** tab, and click **Update Manager**.
9. Click **Import updates** and specify the location of the downloaded files that you copied to the management server.
10. Return to the Welcome page of the web interface, and click **View updates**.
11. Select the updates that you want to install, and click **Install** to start the installation wizard.

Appendix A. Getting help and technical assistance

If you need help, service, or technical assistance or just want more information about IBM products, you will find a wide variety of sources available from IBM to assist you. This section contains information about where to go for additional information about IBM and IBM products, what to do if you experience a problem with your system, and whom to call for service, if it is necessary.

Before you call

Before you call, make sure that you have taken these steps to try to solve the problem yourself:

- Check all cables to make sure that they are connected.
- Check the power switches to make sure that the system and any optional devices are turned on.
- Use the troubleshooting information in your system documentation, and use the diagnostic tools that come with your system. Information about diagnostic tools is in the *Problem Determination and Service Guide* on the *IBM Documentation CD* that comes with your system.
- Go to the IBM support website at <http://www.ibm.com/systems/support/> to check for technical information, hints, tips, and new device drivers or to submit a request for information.

You can solve many problems without outside assistance by following the troubleshooting procedures that IBM provides in the online help or in the documentation that is provided with your IBM product. The documentation that comes with IBM systems also describes the diagnostic tests that you can perform. Most systems, operating systems, and programs come with documentation that contains troubleshooting procedures and explanations of error messages and error codes. If you suspect a software problem, see the documentation for the operating system or program.

Using the documentation

Information about your IBM system and preinstalled software, if any, or optional device is available in the documentation that comes with the product. That documentation can include printed documents, online documents, readme files, and help files. See the troubleshooting information in your system documentation for instructions for using the diagnostic programs. The troubleshooting information or the diagnostic programs might tell you that you need additional or updated device drivers or other software. IBM maintains pages on the World Wide Web where you can get the latest technical information and download device drivers and updates. To access these pages, go to <http://www.ibm.com/systems/support/> and follow the instructions. Also, some documents are available through the IBM Publications Center at <http://www.ibm.com/shop/publications/order/>.

Getting help and information from the World Wide Web

On the World Wide Web, the IBM website has up-to-date information about IBM systems, optional devices, services, and support. The address for IBM System x[®] and xSeries[®] information is <http://www.ibm.com/systems/x/>. The address for IBM BladeCenter[®] information is <http://www.ibm.com/systems/bladecenter/>. The address for IBM IntelliStation[®] information is <http://www.ibm.com/intellistation/>.

You can find service information for IBM systems and optional devices at <http://www.ibm.com/systems/support/>.

Software service and support

Through IBM Support Line, you can get telephone assistance, for a fee, with usage, configuration, and software problems with System x and xSeries servers, BladeCenter products, IntelliStation workstations, and appliances. For information about which products are supported by Support Line in your country or region, see <http://www.ibm.com/services/sl/products/>.

For more information about Support Line and other IBM services, see <http://www.ibm.com/services/>, or see <http://www.ibm.com/planetwide/> for support telephone numbers. In the U.S. and Canada, call 1-800-IBM-SERV (1-800-426-7378).

Hardware service and support

You can receive hardware service through your IBM reseller or IBM Services. To locate a reseller authorized by IBM to provide warranty service, go to <http://www.ibm.com/partnerworld/> and click **Find a Business Partner** on the right side of the page. For IBM support telephone numbers, see <http://www.ibm.com/planetwide/>. In the U.S. and Canada, call 1-800-IBM-SERV (1-800-426-7378).

In the U.S. and Canada, hardware service and support is available 24 hours a day, 7 days a week. In the U.K., these services are available Monday through Friday, from 9 a.m. to 6 p.m.

IBM Taiwan product service

台灣 IBM 產品服務聯絡方式：
台灣國際商業機器股份有限公司
台北市松仁路7號3樓
電話：0800-016-888

IBM Taiwan product service contact information:

IBM Taiwan Corporation
3F, No 7, Song Ren Rd.
Taipei, Taiwan
Telephone: 0800-016-888

Appendix B. Notices

This information was developed for products and services offered in the U.S.A.

IBM may not offer the products, services, or features discussed in this document in other countries. Consult your local IBM representative for information on the products and services currently available in your area. Any reference to an IBM product, program, or service is not intended to state or imply that only that IBM product, program, or service may be used. Any functionally equivalent product, program, or service that does not infringe any IBM intellectual property right may be used instead. However, it is the user's responsibility to evaluate and verify the operation of any non-IBM product, program, or service.

IBM may have patents or pending patent applications covering subject matter described in this document. The furnishing of this document does not give you any license to these patents. You can send license inquiries, in writing, to:

*IBM Director of Licensing
IBM Corporation
North Castle Drive
Armonk, NY 10504-1785
U.S.A.*

INTERNATIONAL BUSINESS MACHINES CORPORATION PROVIDES THIS PUBLICATION "AS IS" WITHOUT WARRANTY OF ANY KIND, EITHER EXPRESS OR IMPLIED, INCLUDING, BUT NOT LIMITED TO, THE IMPLIED WARRANTIES OF NON-INFRINGEMENT, MERCHANTABILITY OR FITNESS FOR A PARTICULAR PURPOSE. Some states do not allow disclaimer of express or implied warranties in certain transactions, therefore, this statement may not apply to you.

This information could include technical inaccuracies or typographical errors. Changes are periodically made to the information herein; these changes will be incorporated in new editions of the publication. IBM may make improvements and/or changes in the product(s) and/or the program(s) described in this publication at any time without notice.

Any references in this information to non-IBM websites are provided for convenience only and do not in any manner serve as an endorsement of those websites. The materials at those websites are not part of the materials for this IBM product, and use of those websites is at your own risk.

IBM may use or distribute any of the information you supply in any way it believes appropriate without incurring any obligation to you.

Trademarks

IBM, the IBM logo, and [ibm.com](http://www.ibm.com) are trademarks of International Business Machines Corp., registered in many jurisdictions worldwide. Other product and service names might be trademarks of IBM or other companies. A current list of IBM trademarks is available on the web at "Copyright and trademark information" at <http://www.ibm.com/legal/copytrade.shtml>.

Adobe and PostScript are either registered trademarks or trademarks of Adobe Systems Incorporated in the United States and/or other countries.

Cell Broadband Engine is a trademark of Sony Computer Entertainment, Inc., in the United States, other countries, or both and is used under license therefrom.

Intel, Intel Xeon, Itanium, and Pentium are trademarks or registered trademarks of Intel Corporation or its subsidiaries in the United States and other countries.

Java and all Java-based trademarks and logos are trademarks or registered trademarks of Oracle and/or its affiliates.

Linux is a registered trademark of Linus Torvalds in the United States, other countries, or both.

Microsoft, Windows, and Windows NT are trademarks of Microsoft Corporation in the United States, other countries, or both.

UNIX is a registered trademark of The Open Group in the United States and other countries.

Important notes

Processor speed indicates the internal clock speed of the microprocessor; other factors also affect application performance.

CD or DVD drive speed is the variable read rate. Actual speeds vary and are often less than the possible maximum.

When referring to processor storage, real and virtual storage, or channel volume, KB stands for 1024 bytes, MB stands for 1,048,576 bytes, and GB stands for 1,073,741,824 bytes.

When referring to hard disk drive capacity or communications volume, MB stands for 1,000,000 bytes, and GB stands for 1,000,000,000 bytes. Total user-accessible capacity can vary depending on operating environments.

Maximum internal hard disk drive capacities assume the replacement of any standard hard disk drives and population of all hard disk drive bays with the largest currently supported drives that are available from IBM.

Maximum memory might require replacement of the standard memory with an optional memory module.

IBM makes no representation or warranties regarding non-IBM products and services that are ServerProven[®], including but not limited to the implied warranties of merchantability and fitness for a particular purpose. These products are offered and warranted solely by third parties.

IBM makes no representations or warranties with respect to non-IBM products. Support (if any) for the non-IBM products is provided by the third party, not IBM.

Some software might differ from its retail version (if available) and might not include user manuals or all program functionality.

Particulate contamination

Attention: Airborne particulates (including metal flakes or particles) and reactive gases acting alone or in combination with other environmental factors such as humidity or temperature might pose a risk to the server that is described in this document. Risks that are posed by the presence of excessive particulate levels or concentrations of harmful gases include damage that might cause the server to malfunction or cease functioning altogether. This specification sets forth limits for particulates and gases that are intended to avoid such damage. The limits must not be viewed or used as definitive limits, because numerous other factors, such as temperature or moisture content of the air, can influence the impact of particulates or environmental corrosives and gaseous contaminant transfer. In the absence of specific limits that are set forth in this document, you must implement practices that maintain particulate and gas levels that are consistent with the protection of human health and safety. If IBM determines that the levels of particulates or gases in your environment have caused damage to the server, IBM may condition provision of repair or replacement of servers or parts on implementation of appropriate remedial measures to mitigate such environmental contamination. Implementation of such remedial measures is a customer responsibility.

Table 8. Limits for particulates and gases

Contaminant	Limits
Particulate	<ul style="list-style-type: none">The room air must be continuously filtered with 40% atmospheric dust spot efficiency (MERV 9) according to ASHRAE Standard 52.2¹.Air that enters a data center must be filtered to 99.97% efficiency or greater, using high-efficiency particulate air (HEPA) filters that meet MIL-STD-282.The deliquescent relative humidity of the particulate contamination must be more than 60%².The room must be free of conductive contamination such as zinc whiskers.
Gaseous	<ul style="list-style-type: none">Copper: Class G1 as per ANSI/ISA 71.04-1985³Silver: Corrosion rate of less than 300 Å in 30 days

¹ ASHRAE 52.2-2008 - *Method of Testing General Ventilation Air-Cleaning Devices for Removal Efficiency by Particle Size*. Atlanta: American Society of Heating, Refrigerating and Air-Conditioning Engineers, Inc.

² The deliquescent relative humidity of particulate contamination is the relative humidity at which the dust absorbs enough water to become wet and promote ionic conduction.

³ ANSI/ISA-71.04-1985. *Environmental conditions for process measurement and control systems: Airborne contaminants*. Instrument Society of America, Research Triangle Park, North Carolina, U.S.A.

Documentation format

The publications for this product are in Adobe Portable Document Format (PDF) and should be compliant with accessibility standards. If you experience difficulties when you use the PDF files and want to request a web-based format or accessible PDF document for a publication, direct your mail to the following address:

*Information Development
IBM Corporation
205/A015
3039 E. Cornwallis Road
P.O. Box 12195
Research Triangle Park, North Carolina 27709-2195*

U.S.A.

In the request, be sure to include the publication part number and title.

When you send information to IBM, you grant IBM a nonexclusive right to use or distribute the information in any way it believes appropriate without incurring any obligation to you.

Telecommunication regulatory statement

This product is not intended to be connected directly or indirectly by any means whatsoever to interfaces of public telecommunications networks, nor is it intended to be used in a public services network.

Electronic emission notices

Note: When attaching a monitor to the equipment, you must use the designated monitor cable and any interference suppression devices supplied with the monitor.

Federal Communications Commission (FCC) statement

Note: This equipment has been tested and found to comply with the limits for a Class A digital device, pursuant to Part 15 of the FCC Rules. These limits are designed to provide reasonable protection against harmful interference when the equipment is operated in a commercial environment. This equipment generates, uses, and can radiate radio frequency energy and, if not installed and used in accordance with the instruction manual, may cause harmful interference to radio communications. Operation of this equipment in a residential area is likely to cause harmful interference, in which case the user will be required to correct the interference at his own expense.

Properly shielded and grounded cables and connectors must be used in order to meet FCC emission limits. IBM is not responsible for any radio or television interference caused by using other than recommended cables and connectors or by unauthorized changes or modifications to this equipment. Unauthorized changes or modifications could void the user's authority to operate the equipment.

This device complies with Part 15 of the FCC Rules. Operation is subject to the following two conditions: (1) this device may not cause harmful interference, and (2) this device must accept any interference received, including interference that may cause undesired operation.

Industry Canada Class A emission compliance statement

This Class A digital apparatus complies with Canadian ICES-003.

Avis de conformité à la réglementation d'Industrie Canada

Cet appareil numérique de la classe A est conforme à la norme NMB-003 du Canada.

Australia and New Zealand Class A statement

Attention: This is a Class A product. In a domestic environment this product may cause radio interference in which case the user may be required to take adequate measures.

European Union EMC Directive conformance statement

This product is in conformity with the protection requirements of EU Council Directive 2004/108/EC on the approximation of the laws of the Member States relating to electromagnetic compatibility. IBM cannot accept responsibility for any failure to satisfy the protection requirements resulting from a nonrecommended modification of the product, including the fitting of non-IBM option cards.

Attention: This is an EN 55022 Class A product. In a domestic environment this product may cause radio interference in which case the user may be required to take adequate measures.

Responsible manufacturer:
International Business Machines Corp.
New Orchard Road
Armonk, New York 10504
914-499-1900

European Community contact:
IBM Technical Regulations, Department M456
IBM-Allee 1, 71137 Ehningen, Germany
Telephone: +49 7032 15-2937
Email: tjahn@de.ibm.com

Germany Class A statement

Deutschsprachiger EU Hinweis:

Hinweis für Geräte der Klasse A EU-Richtlinie zur Elektromagnetischen Verträglichkeit

Dieses Produkt entspricht den Schutzanforderungen der EU-Richtlinie 2004/108/EG zur Angleichung der Rechtsvorschriften über die elektromagnetische Verträglichkeit in den EU-Mitgliedsstaaten und hält die Grenzwerte der EN 55022 Klasse A ein.

Um dieses sicherzustellen, sind die Geräte wie in den Handbüchern beschrieben zu installieren und zu betreiben. Des Weiteren dürfen auch nur von der IBM empfohlene Kabel angeschlossen werden. IBM übernimmt keine Verantwortung für die Einhaltung der Schutzanforderungen, wenn das Produkt ohne Zustimmung der IBM verändert bzw. wenn Erweiterungskomponenten von Fremdherstellern ohne Empfehlung der IBM gesteckt/eingebaut werden.

EN 55022 Klasse A Geräte müssen mit folgendem Warnhinweis versehen werden: "Warnung: Dieses ist eine Einrichtung der Klasse A. Diese Einrichtung kann im Wohnbereich Funk-Störungen verursachen; in diesem Fall kann vom Betreiber verlangt werden, angemessene Maßnahmen zu ergreifen und dafür aufzukommen."

Deutschland: Einhaltung des Gesetzes über die elektromagnetische Verträglichkeit von Geräten

Dieses Produkt entspricht dem "Gesetz über die elektromagnetische Verträglichkeit von Geräten (EMVG)". Dies ist die Umsetzung der EU-Richtlinie 2004/108/EG in der Bundesrepublik Deutschland.

Zulassungsbescheinigung laut dem Deutschen Gesetz über die elektromagnetische Verträglichkeit von Geräten (EMVG) (bzw. der EMC EG Richtlinie 2004/108/EG) für Geräte der Klasse A

Dieses Gerät ist berechtigt, in Übereinstimmung mit dem Deutschen EMVG das EG-Konformitätszeichen - CE - zu führen.

Verantwortlich für die Einhaltung der EMV Vorschriften ist der Hersteller:

International Business Machines Corp.
New Orchard Road
Armonk, New York 10504
914-499-1900

Der verantwortliche Ansprechpartner des Herstellers in der EU ist:

IBM Deutschland
Technical Regulations, Department M456
IBM-Allee 1, 71137 Ehningen, Germany
Telephone: +49 7032 15-2937
Email: tjahn@de.ibm.com

Generelle Informationen:

Das Gerät erfüllt die Schutzanforderungen nach EN 55024 und EN 55022 Klasse A.

VCCI Class A statement

この装置は、クラス A 情報技術装置です。この装置を家庭環境で使用すると電波妨害を引き起こすことがあります。この場合には使用者が適切な対策を講ずるよう要求されることがあります。 VCCI-A

This is a Class A product based on the standard of the Voluntary Control Council for Interference (VCCI). If this equipment is used in a domestic environment, radio interference may occur, in which case the user may be required to take corrective actions.

Japan Electronics and Information Technology Industries Association (JEITA) statement

高調波ガイドライン適合品

Japanese Electronics and Information Technology Industries Association (JEITA)
Confirmed Harmonics Guideline (products less than or equal to 20 A per phase)

Korean Class A warning statement

이 기기는 업무용(A급)으로 전자파적합기기로서 판매자 또는 사용자는 이 점을 주의하시기 바라며, 가정외의 지역에서 사용하는 것을 목적으로 합니다.

Russia Electromagnetic Interference (EMI) Class A statement

ВНИМАНИЕ! Настоящее изделие относится к классу А.
В жилых помещениях оно может создавать радиопомехи, для
снижения которых необходимы дополнительные меры

People's Republic of China Class A electronic emission statement

声 明

此为 A 级产品。在生活环境中，
该产品可能会造成无线电干扰。
在这种情况下，可能需要用户对其
干扰采取切实可行的措施。

Taiwan Class A compliance statement

警告使用者：
這是甲類的資訊產品，在
居住的環境中使用時，可
能會造成射頻干擾，在這
種情況下，使用者會被要
求採取某些適當的對策。

Index

A

- accessible documentation 77
- acoustical noise emissions 6
- adapter
 - installation 39
 - supported 39
- adapter ServeRAID
 - installing 41
- administrator password
 - clear 55
 - set 55
- air baffle
 - removing 28
- ASM event log 7
- assistance, getting 73
- ASU 60
- attention notices 4
- availability 9

B

- backup firmware
 - starting 57
- bays 5
- BIOS 7
- blue on a component 19
- boot manager program
 - using 57

C

- cables
 - connecting 48
- caution statements 4
- CD-RW/DVD
 - drive activity LED 12
 - eject button 12
- Class A electronic emission notice 78
- completing
 - the options installation 45
- components
 - on the server 18
- configuration programs
 - LSI Configuration Utility 51
- configuration, server
 - updating 49
- configuring
 - with ServerGuide 58
- configuring the server 51
- connecting
 - the cables 48
- connector
 - Ethernet 14
 - power supply 14
 - serial 14
 - USB 12, 14

- connector (*continued*)
 - video
 - rear 14
- connectors
 - on the rear of the server 13
- connectors, external system board 21
- connectors, internal system board 20
- contamination, particulate and gaseous 6, 77
- controllers
 - Ethernet 65
- controls, LEDs, and power 11
- creating
 - a software RAID array 68
 - RAID array 68

D

- danger statements 4
- device drivers 11
- devices, static-sensitive
 - handling 27
- dimension 6
- DIMMs
 - installing 30
- disable
 - a software RAID array 69
- documentation
 - Documentation Browser 2
 - Documentation CD 2
- documentation format 77
- documentation, updated
 - finding 4
- drives 8
 - installing 34
- DSA 7
- DSA log 7
- DVD drive
 - installing 37
- Dynamic System Analysis 7

E

- electrical input 6
- electronic emission Class A notice 78
- embedded hypervisor
 - using 64
- environment 6
- Ethernet
 - activity status LED 13
 - link status LED 13
- Ethernet connector 14
- Ethernet support 8
- expansion bays 5
- external, system board connectors 21

F

- FCC Class A notice 78
- features 5
 - ServerGuide 58
- finding
 - updated documentation 4
- firmware updates 1, 11
- Flash utilities 60
- formatting
 - hard disk drive 68
- front view
 - LED location 11
- front view of the server 11

G

- gaseous contamination 6, 77
- getting help 73
- guidelines
 - for options installation 25
 - for system reliability 26

H

- handling static-sensitive devices 27
- hard disk drive
 - formatting 68
 - installing 34
- hard disk drive activity LED 12, 13
- hard disk drive status LED 13
- hardware
 - requirements 2
- hardware service and support 74
- heat output 6
- help, getting 73
- humidity 6
- hypervisor 7
- hypervisor flash device
 - installing 44

I

- IBM Advanced Settings Utility program
 - overview 70
- IBM Support Line 74
- IBM System x Server Firmware
 - Setup utility 61
 - tools and utilities 60
- IBM Systems Director 9, 51
 - systems management tool 10
 - updating 70
- IMM
 - managing tools and utilities 60
- IMM2 61
- important notices 4
- installation guidelines 25
- installation order
 - memory modules 33
- installation, options
 - completing 45

- installing
 - an optional DVD drive 37
 - hard disk drive 34
 - hot-swap power supply 44
 - hypervisor flash device 44
 - memory modules 30
 - riser-card assembly 45
 - ServeRAID adapter 41
- installing drives 34
- installing options 17
- integrated functions 5
- integrated integrated management module 15
- integrated management module
 - event log 7
 - overview 7
- internal, system board connectors 20
- IPMI event log 7
- IPMItool 60

J

- jumpers
 - on the system board 22

L

- LED
 - AC power LED 13
 - DC power LED 14
 - Ethernet-activity status 13
 - Ethernet-link status 13
 - for CD-RW/DVD drive activity 12
 - for hard disk drive activity 12, 13
 - for hard disk drive status 13
 - Power-error LED 14
 - power-on 12
 - power-on button 12
 - system locator 12
 - system-error 12
- LEDs
 - on the system board 24
- License Agreement for Machine Code 4
- local area network (LAN) 8
- LSI Configuration program 66

M

- management, system 7
- memory
 - specifications 5
- memory module
 - installing 30
 - order of installation 33
- memory support 8
- menu choices
 - for the Setup utility 52
- microprocessor
 - specifications 5

N

- NOS installation
 - with ServerGuide 59
- notes 4
- notes, important 76
- notices 75
 - electronic emission 78
 - FCC, Class A 78
- notices and statements 4

O

- online documentation 1
- online publications 4
- operating system 17, 59
- operating-system event log 7
- optional optical drive
 - specifications 5
- options
 - installing 17
- order of installation
 - memory modules 33

P

- particulate contamination 6, 77
- password 55
 - administrator 55
 - power-on 55
- PCI expansion slots 5
- PCI riser-card assembly
 - removing 29
- power
 - specifications 6
 - supply 5
- power features
 - of the server 14
- power on and working inside the server 27
- power supply 9
 - hot-swap 43
 - installing 43, 44
- Power supply with AEM
 - AC power LED 13
 - DC power LED 14
 - Power-error LED 14
- power-on LED 12, 14
- power-on password
 - clear 55
 - set 55
- public services network, use in 78
- public telecommunications network, connection to 78

R

- RAID array
 - creating 68
- RAID support 8
- RAS features 9
- rear view
 - of the server 13

- reliability 9
- removing
 - air baffle 28
 - PCI riser-card assembly 29
 - top cover 27
- replacing
 - top cover 47
- requirements
 - software and hardware 2
- reset button 12
- reset IMM2 61
- riser card
 - slots 25
- riser-card assembly
 - installing 45

S

- Safety Information 4
- serial connector 14
- serial number 2
- server
 - configuring 51
 - offerings 7
 - power features 14
 - turning it off 14
 - turning it on 14
 - working inside with the power on 27
- server , backup firmware
 - starting 57
- server components 18
- server configuration
 - updating 49
- server controls, LEDs, and power 11
- server rear view 13
- server shutdown 14
- server, front view 11
- ServerGuide 59
 - features 58
 - NOS installation 59
 - setup 58
 - using 57
- ServerGuide CD 2, 9
- ServerProven 17, 25
- serviceability 9
- Setup utility
 - menu choices 52
 - starting 52
 - using 52
- shutting down the server 14
- size 6
- slot locations
 - adapter 25
 - PCI Express 25
- slots
 - PCI expansion 5
- software
 - requirements 2
- software RAID array
 - creating 68
 - disable 69

- software service and support 74
- specifications 5
- standby 24
- standby mode 14
- starting
 - the backup firmware 57
 - the Setup utility 52
- statements and notices 4
- static-sensitive devices
 - handling 27
- support, web site 73
- system
 - error LED front 12
 - locator LED, front 12
- system board
 - jumpers 22
 - LEDs 24
- system board external connectors 21
- system board internal connectors 20
- system reliability guidelines 26
- Systems Director 51
- systems management 7
- systems management tool
 - IBM Systems Director 10

T

- telephone numbers 74
- temperature 6
- TOE 5
- tools 60
 - Flash utilities 60, 61
 - IPMItool 60
- ToolsCenter for System x and BladeCenter 4
- top cover
 - removing 27
 - replacing 47
- trademarks 75
- turning off the server 14
 - integrated integrated management module 15
- turning on the server 14

U

- UEFI 7
- Unified Extensible Firmware Interface 7
- United States electronic emission Class A notice 78
- United States FCC Class A notice 78
- UpdateXpress 11
- updating
 - IBM Systems Director 70
 - Systems Director, IBM 70
 - the server configuration 49
- USB
 - connector 12, 14
- using
 - embedded hypervisor 64
 - LSI Configuration program 66
 - the boot manager program 57
 - the Setup utility 52
- Using IBM Advanced Settings Utility (ASU) 60

- utilities
 - See tools
- Utility program
 - IBM Advanced Settings 70
- utility, Setup
 - menu choices 52
 - starting 52
 - using 52

V

- video connector
 - rear 14
- video controller, integrated
 - specifications 6
- VMware hypervisor 7

W

- Wake on LAN feature 14
- web site
 - publication ordering 73
 - support 73
 - support line, telephone numbers 74
- weight 6
- what the server offers 7
- working inside the server
 - with the power on 27



Part Number: 81Y5874

Printed in USA

(1P) P/N: 81Y5874

