

ALL MATERIALS CONFORM TO THE RoHS COMPLIANCE.

RoHS

REV.	R.S. No.	DESCRIPTION	DATE

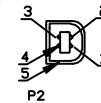
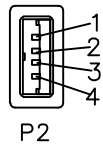
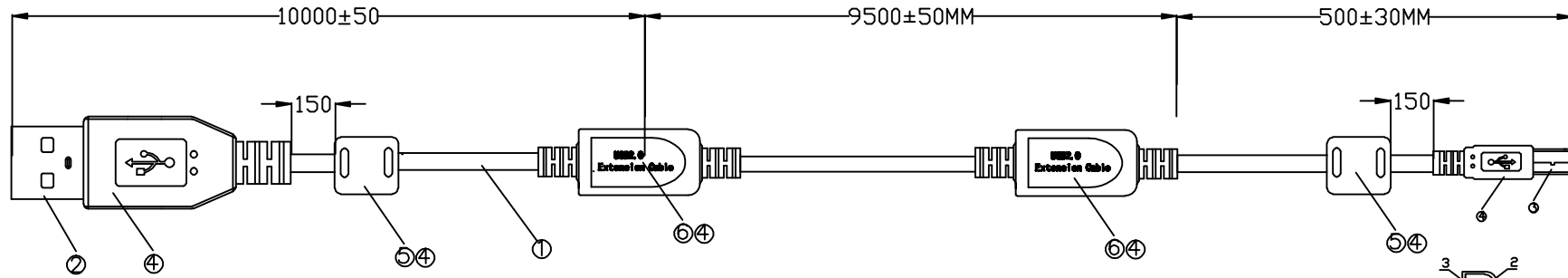

OD=5.0±0.20MM

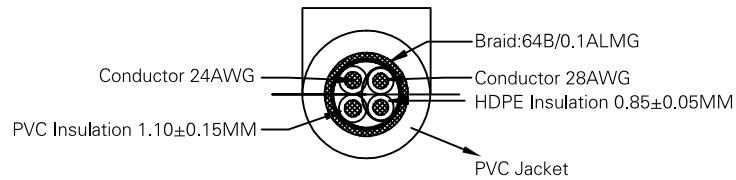

P1	P2	colour
1	1	RED
2	2	white
3	3	green
4	4	BLACK
5	5	D

⑥	PCBA	USB PCBA F1.1 48P.		2	
⑤	magnet ring	magnet ring BLACK			
④	holding material	PVC 4SP COLOR: BLACK	kg	0.012	
③	Connector	USB B/M gold plated	PCS	1	
②	Connector	USB A/M gold plated	PCS		
①	CABLE	PVC,OD=5.0(28AWG(TS))*2C+24AWG(TS) *2C+64*0 10(ALMG)+AL BLACK	mm		
NO.	Item				

DRAWN
Jack
DATE
01/02-2023

CHECKED
Alice
DATE
01/02-2023

CUSTOMER APPROVED
Emil Olsen
DATE



USB2.0 CABLE A MALE
/ USB B M CONNECTOR-20 M



PAGE
1 OF 1
REVISION
A

CUSTOMER P/N
USBAB20B-ACTIVE

ITEM P/N	DESCRIPTION	VENDOR	Q'TY	UNIT	MM	SCALE	FREE	Cableking P/N	YD-20140311-001
----------	-------------	--------	------	------	----	-------	------	---------------	-----------------